

CLAAS

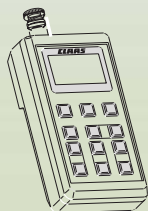

ROLLANT 250 with CCT
ROLLANT 254 with CCT
ROLLANT 255 with CCT

Technical Systems

Diagnosis

SERVICE & PARTS

Contents

- 1.0 Control terminal service menu
(up to module 1 no. 835023.2)**
 - 1.1 Service menu structure 2
 - 1.2 Additional information about page "Service 1" .. 3
 - 1.3 Input testing 4
 - 1.4 Output testing 5
 - 1.5 Error display 6
 - 1.6 Key test 7

- 2.0 Control terminal service menu
(from module 1 no. 835023.3)**
 - 2.1 Service menu structure 8
 - 2.2 Additional information about page "Service 1" .. 9
 - 2.3 Input testing 10
 - 2.4 Output testing 11
 - 2.5 Error display 13
 - 2.6 Key test 14

- 3.0 Sensor test**
 - Film sensor 15
 - Stop bow pulse 16
 - Wrapping arm pulse 17
 - Home position 17
 - Wrapping table raised 18
 - Bale on wrapping table 18
 - Bale in tipping cradle 18
 - Tipping cradle lowered 19
 - Tailgate closed 19
 - Tailgate open 20
 - Wrapping start signal 20
 - Tying start signal 20

- 4.0 Fault table 21**

1.0 Control terminal service menu (up to module 1 no. XXX XXX.2)

1.1 Service menu structure (up to module 1 no. 835023.2)

This menu serves as a tool in fault-finding. It shows the status of various electrical components such as e.g. speed, voltage, pressure and switch positions.

To enter the service menu, press the keys „Scroll main menu”, „Plus key” and „Minus key” at the same time.
The following mask appears:

Page "8/1 (Service 1)"

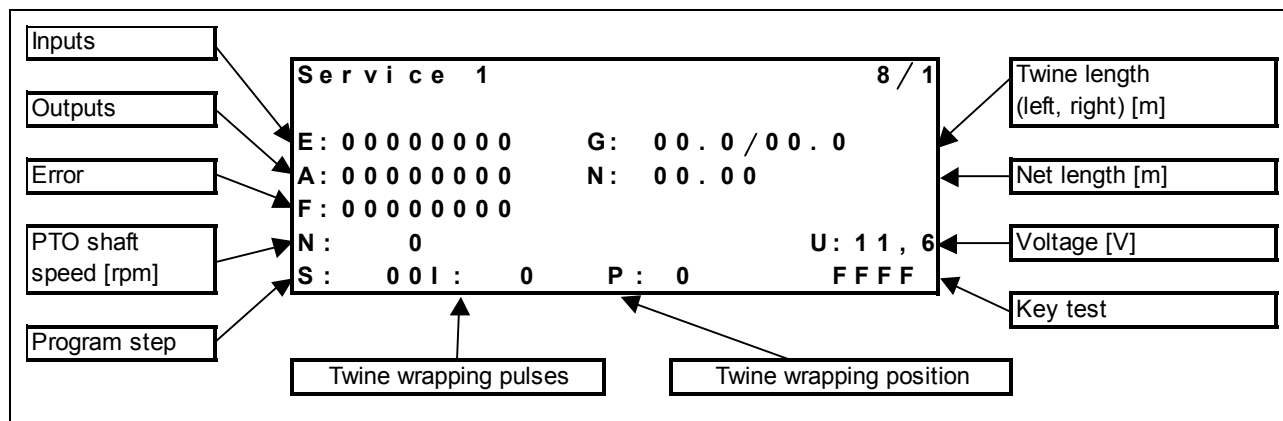

1.2 Additional information about page "8/1 (Service 1)" (up to module 1 no. 835023.2)

Menu item	Remark
(E:) Inputs	The condition of various circuits connected with the modules is displayed here. Each numeric character corresponds to one circuit. 0 = Circuit open 1 = Circuit closed
(A:) Outputs	The condition of various circuits connected with the modules is displayed here. Each numeric character corresponds to one circuit. 0 = Circuit open 1 = Circuit closed
(F:) Error	Malfunctions are displayed here. Each numeric character corresponds to one error. 0 = No error 1 = Error
(N:) PTO shaft speed	The calculated PTO shaft speed in revolutions per minute is displayed here (this speed is measured by the drive speed sensor).
(S:) Program step	The progress of the automatic twine and net wrapping is displayed here in program steps which are listed below.
(I:) Twine wrapping pulses	Pulses from the drive speed sensor are measured here during twine wrapping as long as the electro-magnetic twine clutch is engaged (this makes the module measure the bale speed while the twine arms are in motion)
(P:) Twine wrapping position	Pulses are counted here during twine wrapping as long as the electro-magnetic twine clutch is engaged (here the module identifies the position of the twine arms)
Key test	A combination of characters and numbers is displayed here to test the function of the keys on the Control Terminal.
(U:) Voltage	The supply voltage is displayed here in Volt to the first decimal point.
(N:) Net length	The net length is displayed here in metres to the second decimal point (this value is measured by the net speed sensor when wrapping is activated).
(G:) Twine length (left, right)	The twine length on the left and right side is displayed here in metres to the first decimal point (these values are measured by the twine speed sensors when wrapping is activated).

1.3 Input testing (up to module 1 no. 835023.2)
Continuity test

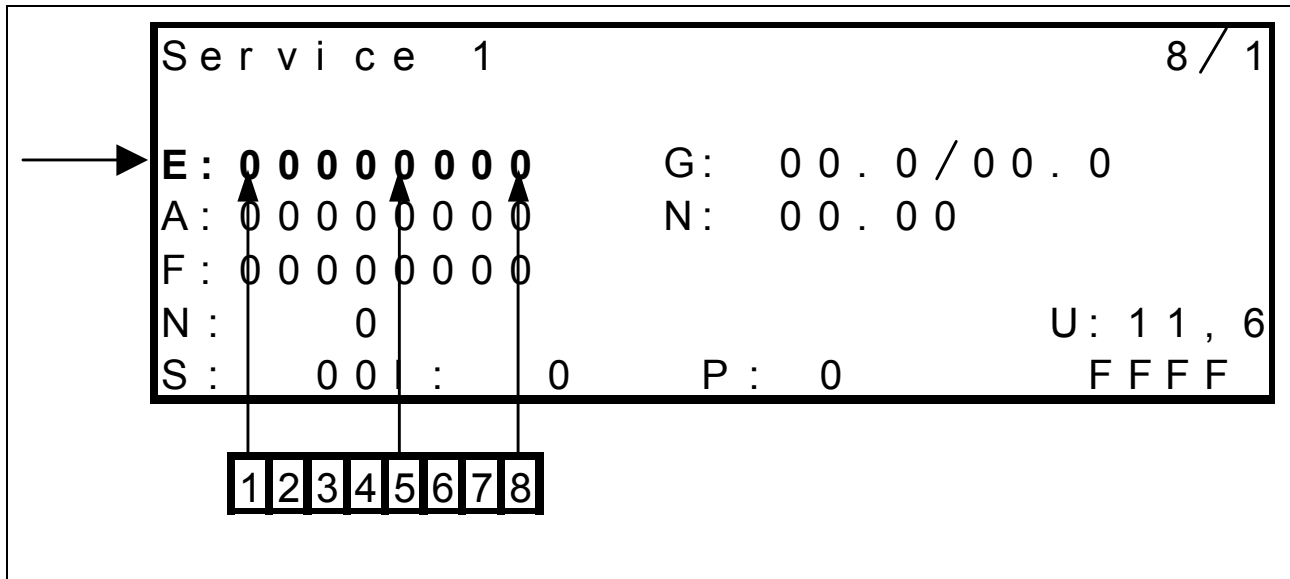

Eight numeric characters are available for input diagnosis in line „E”, each of them being assigned to one circuit.

The numeric characters may assume the following values:

- 0 = Circuit open or
- 1 = Circuit closed.

All numeric characters show the respective state independently of each other.

Dependencies and switching sequences which may occur in normal operation have no influence.

Numeric character	Designation		Display
E1	Z35	Cam track switch	0 = Switch not actuated 1 = Switch actuated
E2	Z6	Bale ejector switch	0 = Switch actuated 1 = Switch not actuated
E3	Z17	Tailgate open switch	0 = Switch not actuated 1 = Switch actuated
E4	Z16	Tailgate closed switch	0 = Switch actuated 1 = Switch not actuated
E5	B22	Net roll speed sensor	1 = No metal in sensor or signal line connected to earth line 0 = Metal in sensor
E6	B13	Left twine roll speed sensor	1 = No metal in sensor or signal line connected to earth line 0 = Metal in sensor
E7	B14	Right twine roll speed sensor	1 = No metal in sensor or signal line connected to earth line 0 = Metal in sensor
E8	B9	Drive speed sensor	1 = No metal in sensor or signal line connected to earth line 0 = Metal in sensor

1.4 Output testing (up to module 1 no. 835023.2)
Testing the actuation by the modules

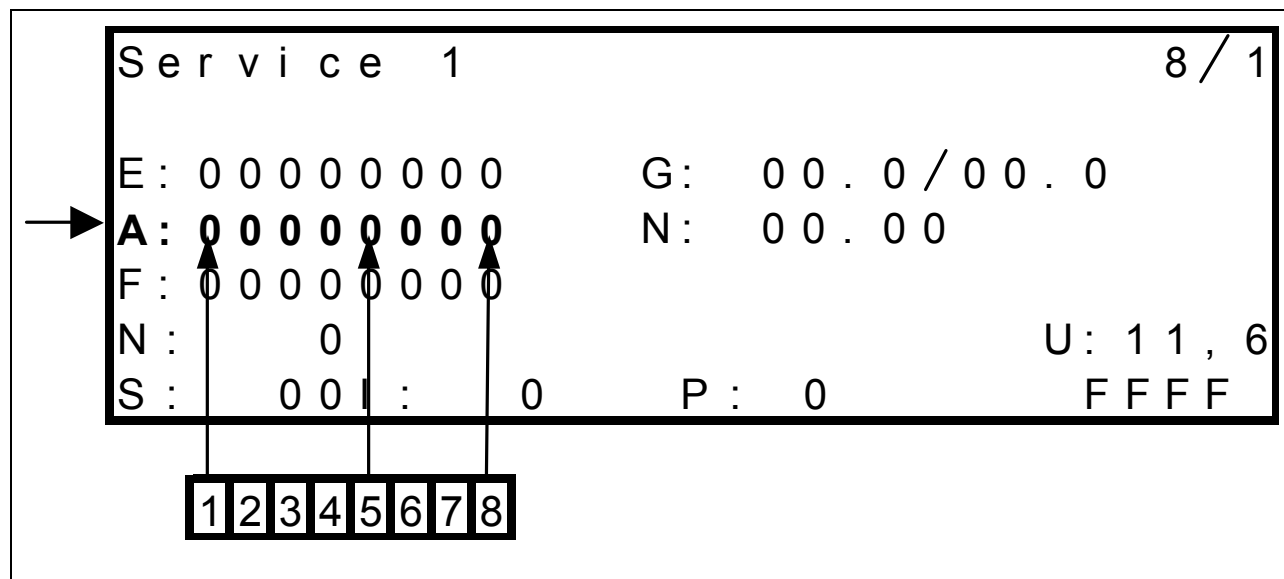

Eight numeric characters are available for output diagnosis in line „A”, each of them being assigned to one solenoid valve.

The numeric characters only indicate if a solenoid valve is actuated by the corresponding module.

For diagnosis purposes, the corresponding function must be activated.

The numeric characters may assume the following values:

- 0 = Solenoid valve is not actuated by the module
- or
- 1 = Solenoid valve is actuated by the module.

Dependencies and switching sequences which may occur in normal operation have an influence.

Numeric character	Designation		Display
A1	K93	Rotocut [knives] ON / OFF relay	0 = not activated (RC OFF) 1 = activated (RC ON)
A2	Y49	Lower pickup solenoid coil	0 = not activated 1 = activated
A3	Y48	Raise pickup solenoid coil	0 = not activated 1 = activated
A4	Y28	Close tailgate solenoid coil	0 = not activated 1 = activated
A5	Y27	Open tailgate solenoid coil	0 = not activated 1 = activated
A6	Y77	Circulation shut-off valve solenoid coil	0 = not activated 1 = activated
A7	Y38	Electro-magnetic twine clutch solenoid coil	0 = not activated 1 = activated
A8	Y41	Electro-magnetic net clutch solenoid coil	0 = not activated 1 = activated

1.5 Error display (up to module 1 no. 835023.2)

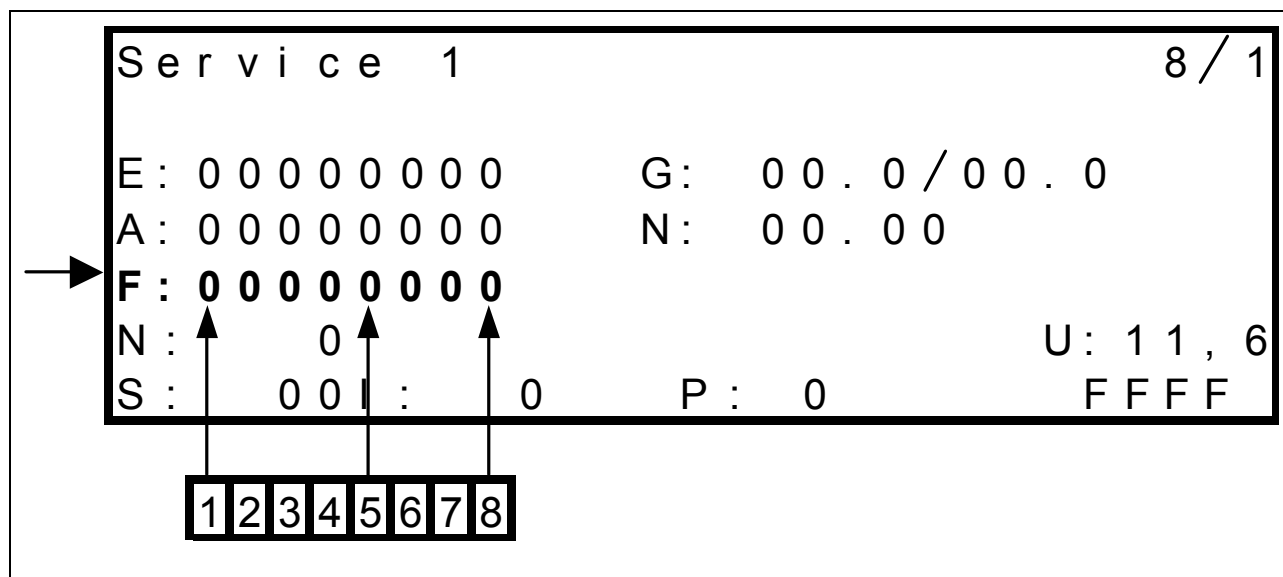

Eight numeric characters are available for error display in line „F”, each of them being assigned to one error.

The numeric characters may assume the following values:

0 = No error or

1 = Error.

All numeric characters show the respective state independently of each other.

Dependencies and switching sequences which may occur in normal operation have no influence.

Numeric characters	Reason	Remark	Symbol in work menu
F1	Free	Not used	
F2	System fault (CAN bus)	No signal from CAN bus	
F3	Free	Not used	
F4	Cam track	No signal change from cam track switch during wrapping process	
F5	Bale ramp	When fault occurs with bale ejection during automatic net or twine wrapping (see additional information)	
F6	Net wrapping	When fault occurs in net wrapping process	
F7	No twine on right-hand side	No signal from right-hand twine counter during wrapping process	
F8	No twine on left-hand side	No signal from left-hand twine counter during wrapping process	

1.6 Key test (up to module 1 no. 835023.2)

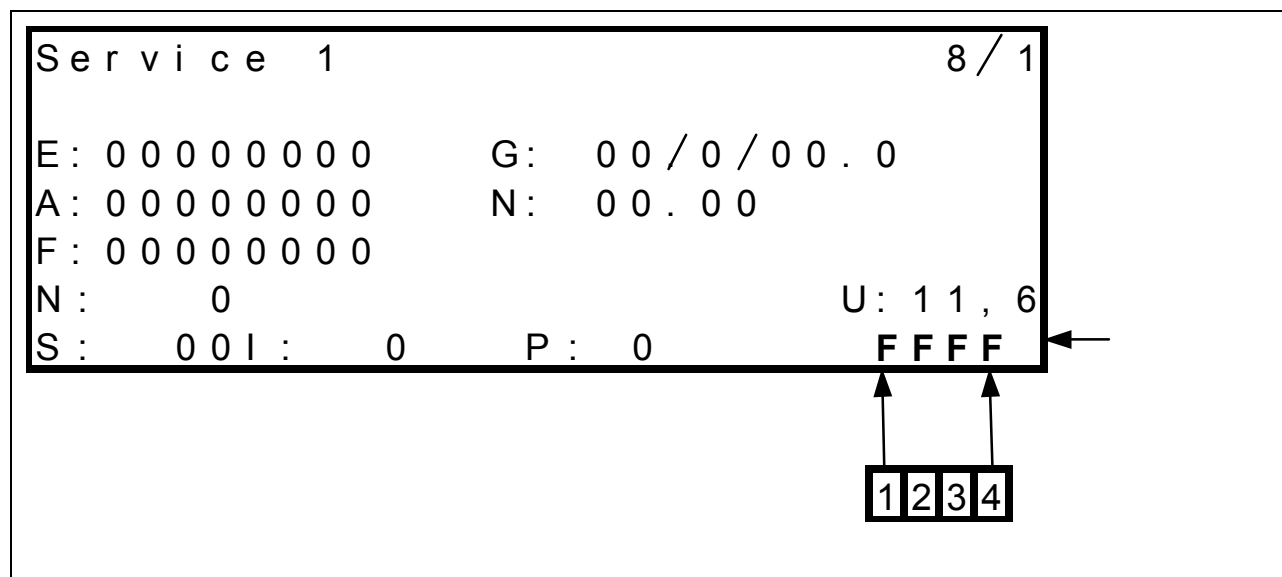

Four numeric characters are available for key testing in line (1) shown above.
 Pushing a key on the Control Terminal produces one of the combinations of numbers and characters shown below which allow checking the function.

Example: When pushing the „Minus” key, the display reads „FDFF”.

Key	Designation	Display			
		1	2	3	4
	Scroll through main menu	E	F	F	F
	Scroll through second screen	D	F	F	F
	ROTOCUT knives ON	B	F	F	F
	ROTOCUT knives OFF	7	F	F	F
	Manual wrapping	F	F	E	F
-	Minus key	F	D	F	F
+	Plus key	F	F	D	F
	Wrapping type	F	E	F	F
	Open tailgate	F	B	F	F
	Close tailgate	F	7	F	F
	Raise pickup	F	F	B	F
	Lower pickup	F	F	7	F

2.0 Control terminal service menu (from module 1 no. 835023.3)

2.1 Service menu structure (from module 1 no. XXX XXX.3)

This menu serves as a tool in fault-finding. It shows the status of various electrical components such as e.g. speed, voltage, pressure and switch positions.

To enter the service menu, press the keys „Scroll main menu”, „Plus key” and „Minus key” at the same time.

The following mask appears:

Page "8/1 (Service 1)"

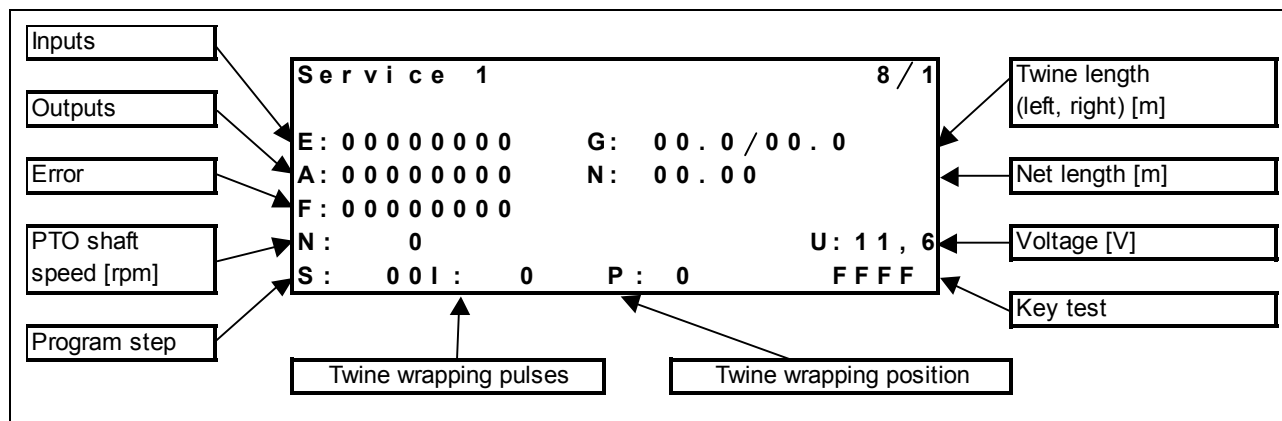

2.2 Additional information about page "8/1 (Service 1)" (from module 1 no. 835023.3)

Menu item	Remark
(E:) Inputs	The condition of various circuits connected with the modules is displayed here. Each numeric character corresponds to one circuit. 0 = Circuit open 1 = Circuit closed
(A:) Outputs	The condition of various circuits connected with the modules is displayed here. Each numeric character corresponds to one circuit. 0 = Circuit open 1 = Circuit closed
(F:) Error	Malfunctions are displayed here. Each numeric character corresponds to one error. 0 = No error 1 = Error
(N:) PTO shaft speed	The calculated PTO shaft speed in revolutions per minute is displayed here (this speed is measured by the drive speed sensor).
(S:) Program step	The progress of the automatic twine and net wrapping is displayed here in program steps which are listed below.
(I:) Twine wrapping pulses	Pulses from the drive speed sensor are measured here during twine wrapping as long as the electro-magnetic twine clutch is engaged (this makes the module measure the bale speed while the twine arms are in motion).
(P:) Twine wrapping position	Pulses are counted here during twine wrapping as long as the electro-magnetic twine clutch is engaged (here the module identifies the position of the twine arms).
Key test	A combination of characters and numbers is displayed here to test the function of the keys on the Control Terminal.
(U:) Voltage	The supply voltage is displayed here in Volt to the first decimal point.
(N:) Net length	The net length is displayed here in metres to the second decimal point (this value is measured by the net speed sensor when wrapping is activated).
(G:) Twine length (left, right)	The twine length on the left and right side is displayed here in metres to the first decimal point (these values are measured by the twine speed sensors when wrapping is activated).

2.3 Input testing (from module 1 no. 835023.3)
Continuity test

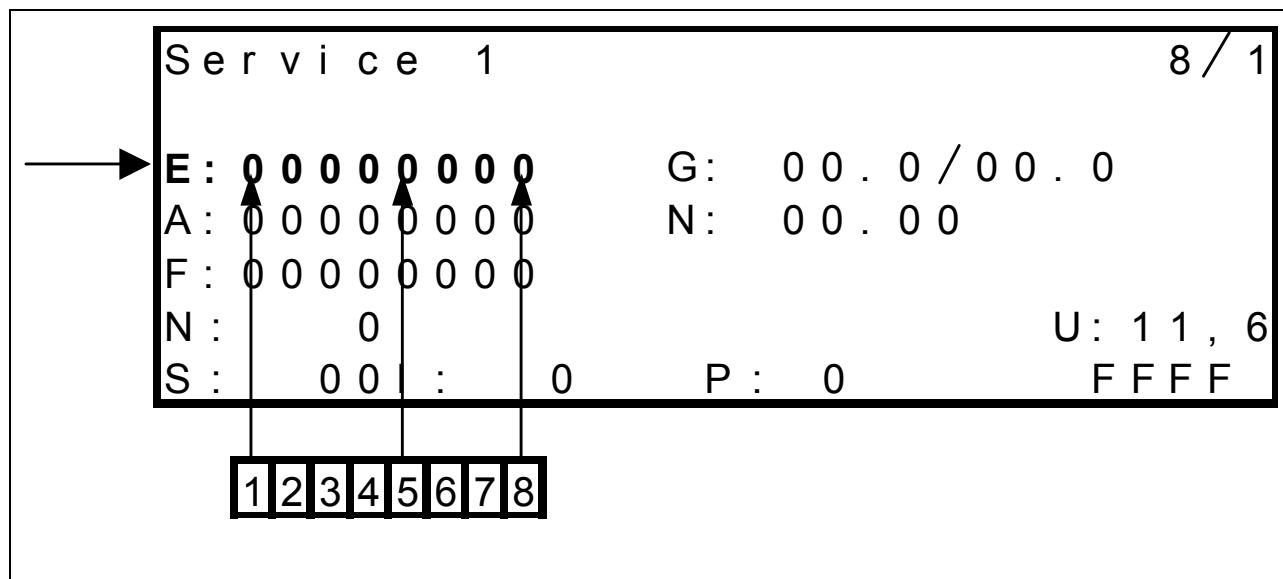

Eight numeric characters are available for input diagnosis in line „E”, each of them being assigned to one circuit.

The numeric characters may assume the following values:

0 = Circuit open or

1 = Circuit closed.

All numeric characters show the respective state independently of each other.

Dependencies and switching sequences which may occur in normal operation have no influence.

Numeric character	Designation		Display
E1	Z35	Cam track switch	0 = Switch not actuated 1 = Switch actuated
E2	Z6	Bale ejector switch	0 = Switch actuated 1 = Switch not actuated
E3	Z17	Tailgate open switch	0 = Switch not actuated 1 = Switch actuated
E4	Z16	Tailgate closed switch	0 = Switch actuated 1 = Switch not actuated
E5	B22	Net roll speed sensor	1 = No metal in sensor or signal line connected to earth line 0 = Metal in sensor
E6	B13	Left twine roll speed sensor	1 = No metal in sensor or signal line connected to earth line 0 = Metal in sensor
E7	B14	Right twine roll speed sensor	1 = No metal in sensor or signal line connected to earth line 0 = Metal in sensor
E8	B9	Drive speed sensor	1 = No metal in sensor or signal line connected to earth line 0 = Metal in sensor

2.4 Output testing (from module 1 no. 835023.3)
Testing the actuation by the modules

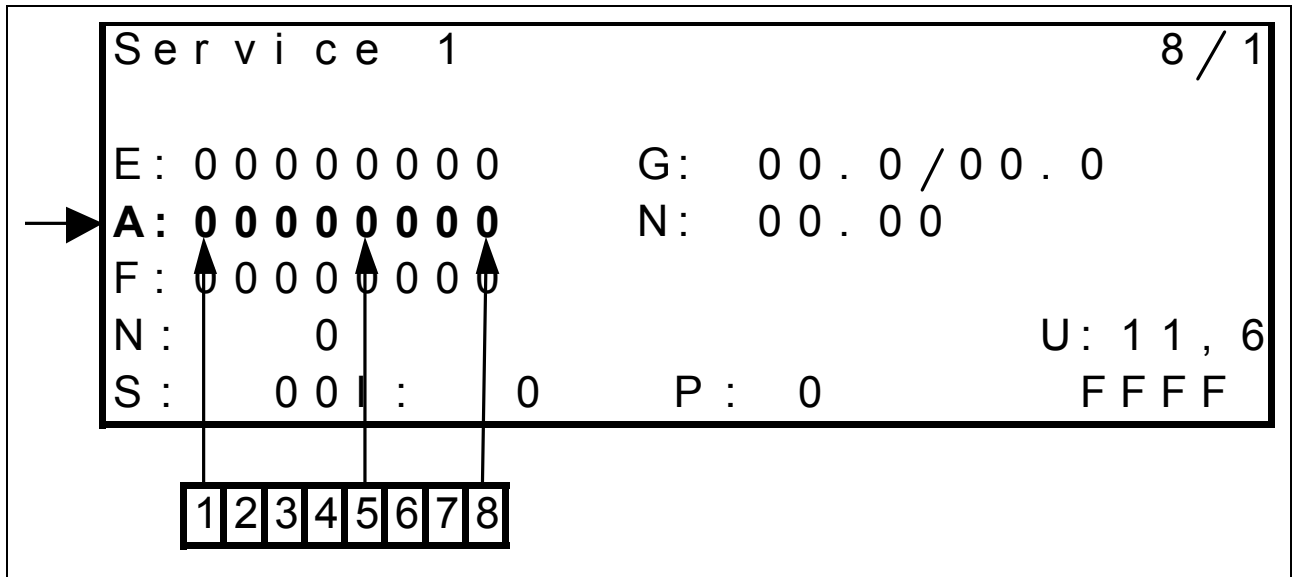

Eight numeric characters are available for output diagnosis in line „A”, each of them being assigned to one solenoid valve. The numeric characters only indicate if a solenoid valve is actuated by the corresponding module.

For diagnosis purposes, the corresponding function must be activated.

The numeric characters may assume the following values:

- 0 = Solenoid valve is not actuated by the module
- or
- 1 = Solenoid valve is actuated by the module.

Dependencies and switching sequences which may occur in normal operation have an influence.

Numeric character	Designation		Display
A1	K93	Rotocut [knives] ON / OFF relay	0 = not activated (RC OFF) 1 = activated (RC ON)
A2	Y49	Lower pickup solenoid coil	0 = not activated 1 = activated
A3	Y48	Raise pickup solenoid coil	0 = not activated 1 = activated
A4	Y28	Close tailgate solenoid coil	0 = not activated 1 = activated
A5	Y27	Open tailgate solenoid coil	0 = not activated 1 = activated
A6	Y77	Circulation shut-off valve solenoid coil	0 = not activated 1 = activated
A7	Y38	Electro-magnetic twine clutch solenoid coil	0 = not activated 1 = activated
A8	Y41	Electro-magnetic net clutch solenoid coil	0 = not activated 1 = activated

Output testing, continued (from module 1 no. 835023.3)

Continuity test

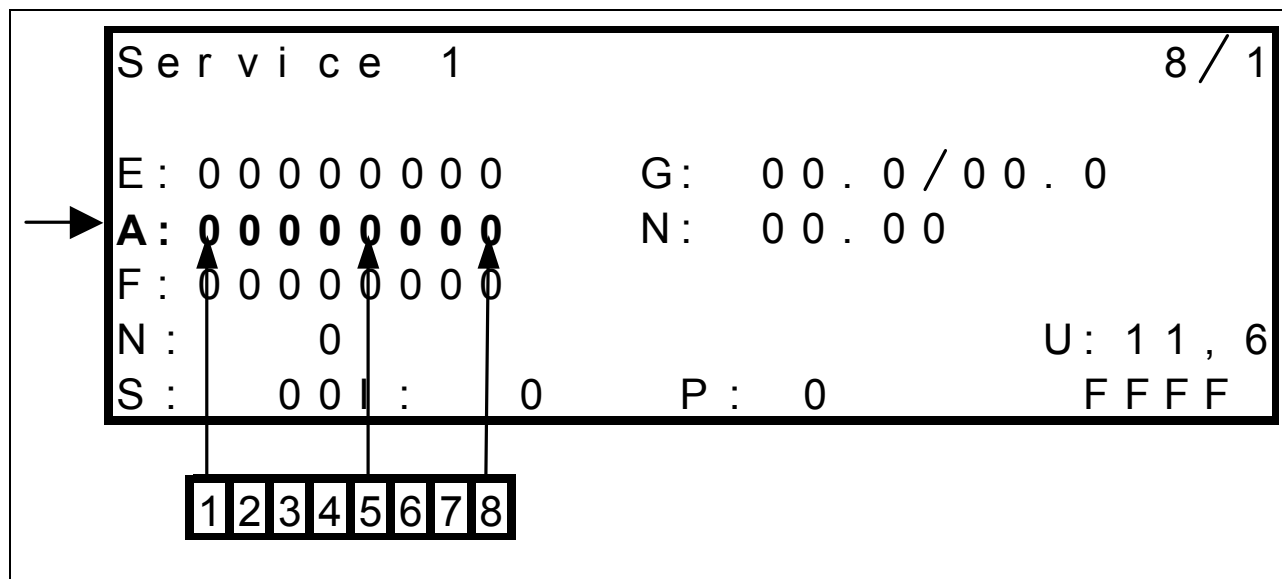

To activate this function, keep the „Minus key” pressed while in the service menu.

Eight numeric characters are available for output diagnosis in line „A”, each of them being assigned to one circuit. It must be ensured that the outputs are not activated (see previous page).

The numeric characters may assume the following values:

0 = Circuit open or

1 = Circuit closed and/or solenoid coil OK.

All numeric characters show the respective state independently of each other. Dependencies and switching sequences which may occur in normal operation have no influence.

Numeric character	Designation		Display
A1	K93	Rotocut [knives] ON / OFF relay	0 = Circuit interrupted 1 = Solenoid coil circuit in relay 85 to 86 OK
A2	Y49	Lower pickup solenoid coil	0 = Circuit interrupted 1 = Solenoid coil circuit OK
A3	Y48	Raise pickup solenoid coil	0 = Circuit interrupted 1 = Solenoid coil circuit OK
A4	Y28	Close tailgate solenoid coil	0 = Circuit interrupted 1 = Solenoid coil circuit OK
A5	Y27	Open tailgate solenoid coil	0 = Circuit interrupted 1 = Solenoid coil circuit OK
A6	Y77	Circulation shut-off valve solenoid coil	0 = Circuit interrupted 1 = Solenoid coil circuit OK
A7	Y38	Electro-magnetic twine clutch solenoid coil	0 = Circuit interrupted 1 = Solenoid coil circuit OK
A8	Y41	Electro-magnetic net clutch solenoid coil	0 = Circuit interrupted 1 = Solenoid coil circuit OK

2.5 Error display (from module 1 no. 835023.3)

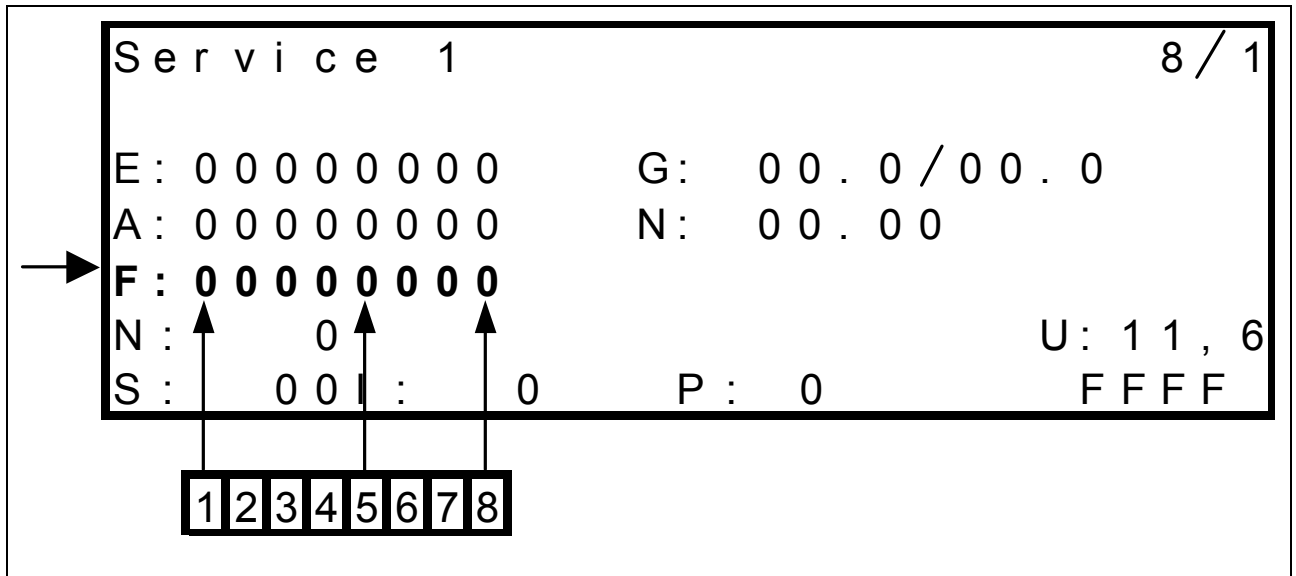







Eight numeric characters are available for error display in line „F”, each of them being assigned to one error.

The numeric characters may assume the following values:

0 = No error or

1 = Error.

All numeric characters show the respective state independently of each other. Dependencies and switching sequences which may occur in normal operation have no influence.

Numeric characters	Reason	Remark	Symbol in work menu
F1	Free	Not used	
F2	System fault (CAN bus)	No signal from CAN bus	
F3	Free	Not used	
F4	Cam track	No signal change from cam track switch during wrapping process	
F5	Bale ramp	When fault occurs with bale ejection during automatic net or twine wrapping (see additional information)	
F6	Net wrapping	When fault occurs in net wrapping process	
F7	No twine on right-hand side	No signal from right-hand twine counter during wrapping process	
F8	No twine on left-hand side	No signal from left-hand twine counter during wrapping process	

2.6 Key test (from module 1 no. 835023.3)

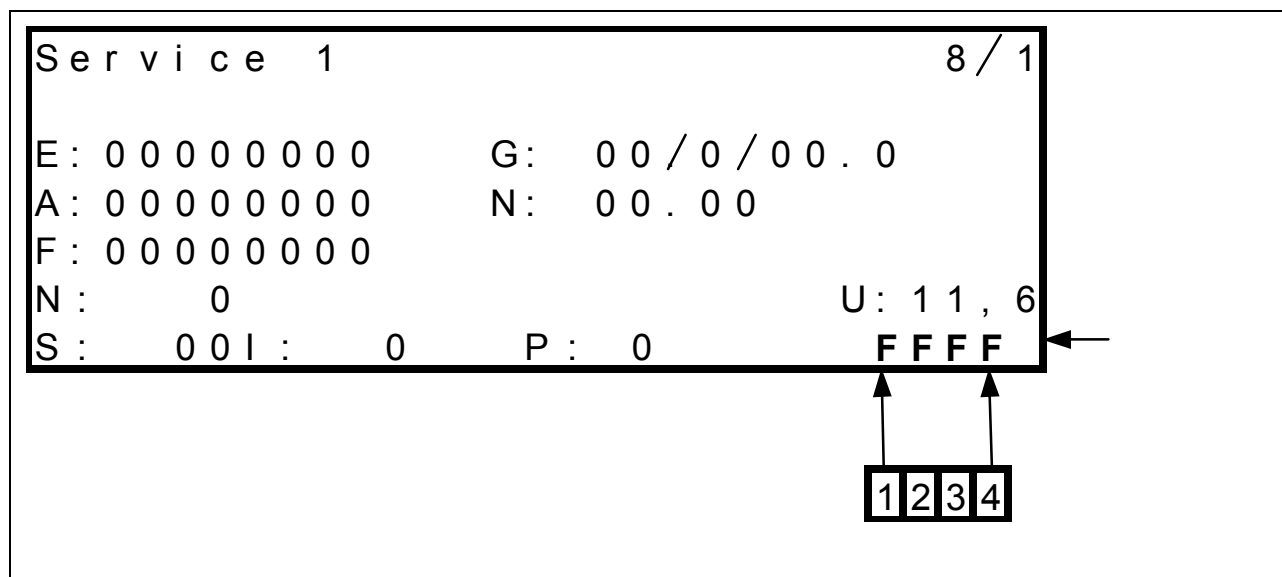

Four numeric characters are available for key testing in line (1) shown above.

Pushing a key on the Control Terminal produces one of the combinations of numbers and characters shown below which allow checking the function.

Example: When pushing the „Minus” key, the display reads „FDFF”.

Key	Designation	Display			
		1	2	3	4
	Scroll through main menu	E	F	F	F
	Scroll through second screen	D	F	F	F
	ROTOCUT knives ON	B	F	F	F
	ROTOCUT knives OFF	7	F	F	F
	Manual wrapping	F	F	E	F
-	Minus key	F	D	F	F
+	Plus key	F	F	D	F
	Wrapping type	F	E	F	F
	Open tailgate	F	B	F	F
	Close tailgate	F	7	F	F
	Raise pickup	F	F	B	F
	Lower pickup	F	F	7	F

3.0 Sensor test

In the menu "Sensor test", the input and output signals of all switches and sensors can be checked.
These signals are checked at the input and output pins of the bale wrapper module A22 – see also "Technical Systems – Electric System".

The description below refers to the operation using the UNIWRAP terminal A30-1.

As an alternative, the sensor test may also be carried out using the Rollant terminal A30 (CCT) in menu 5/... (see also Operating Manual).

The proper condition of the UNIWRAP bale wrapper is described.

Select sensor test

Turn on power supply for the UNIWRAP control box A30-1. To do so, turn on the CCT (CLAAS Control Terminal) A30 of the Rollant.

The display of the control box shows the home position.



Press key as often as needed to display the "Sensor test" menu.

Film sensor pulse



Press the key until "Film sensor pulse: Yes" appears.

Attention

The film ripping monitoring is active when:

- the film ripping monitoring was activated in terminal A30-1
- the wrapping arm is rotating with 20 rpm minimum.

If the film finished or is ripped, the error message "Ripped film" appears in the display.

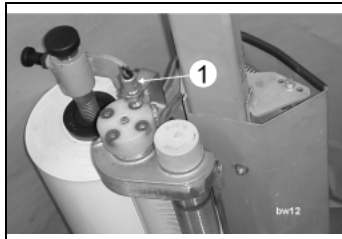

At the top of the stretch rolls, 4 magnets rotate below the stretch sensors (1=B109).

They generate pulses and transmit them to the transmitter coils (2=V11).

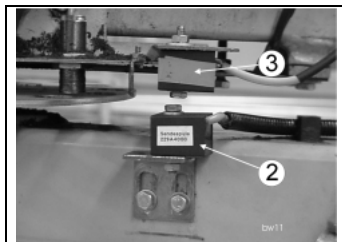

The two transmitter coils (2=V11) are adjustable by means of elongated holes and rotate together with the rotation arm. They receive pulses from the corresponding stretch sensors (1=B109) and build up a magnetic field from these pulses.

The receiver coil (3=V12) is fixed to the frame. It receives the magnetic fields from the transmitter coils (2=V11) during the short period when the two coils are located one above the other. These pulse are fed into module A22.

When the pulses of one or both transmitter coils (2=V11) fail, the error message "Ripped film" appears.

The spacing between transmitter coils and receiver coil must be correctly adjusted (see Settings).

If the spacing is too wide, the error message "Ripped film" will appear as well.

- Test:**
- Ensure that the film ripping monitoring was activated in terminal A30-1.
 - Position the rotation arm so that one of the two transmitter coils (2=V11-1 or V11-2) is located directly under the receiving coil (3=V12).
 - The display reads: **Film sensor pulse: No**
 - Rotate stretch roll rapidly by hand.
(V11-1 under V12 → rotate B109-1
V11-2 under V12 → rotate B109-2)
 - The display reads: **Film sensor pulse: Yes**
 - Repeat this test with the second transmitter coil V11.

Both transmitter coils V11-1 and/or V11-2 must be checked for the film ripping monitoring to work properly.

Stop bow pulse



Press the key until "Stop bow pulse: No" appears

Actuate stop bow by approx. 300 mm, the display must read: "Stop bow pulse: Yes"

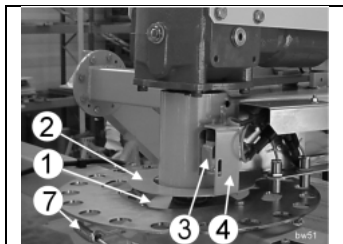

- 1 The **plastic finger** is actuated by the safety bow via an adjustable rod (7).
- 2 The **belleville spring** is pressed up by the plastic finger (1) when the safety bow is actuated.
- 3 The **switch** Z91-1 / Z91-2 is actuated by the angle plate (4). In case of danger, the safety bow switches (3=Z91-1 / Z91-2) immediately stop the rotation of the wrapping arm. The switches (3=Z91-1 / Z91-2) are adjustable in elongated holes.
- 4 The **angle plate** actuates the switches (3=Z91-1 / Z91-2) and is linked to the belleville spring (2).
- 7 The **rod** transmits the movement of the safety bow to the plastic finger (1).

- Test:**
- Wrapping arm is positioned along the longitudinal axis of the bale wrapper.
 - When the wrapping arm is not actuated, the display reads: **Stop bow pulse: No.**
 - Actuate both stop bows one after the other.
 - After an actuating path of 300 mm, the display reads: **Stop bow pulse: Yes.**

Wrapping arm pulse

Press the key until "Wrapping arm pulse: No" appears.

The wrapping arm pulses are displayed only when the wrapping arm rotates.

They are counted by means of a sensor and a perforated disc.

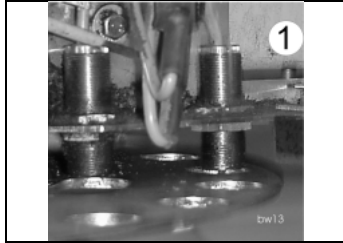

Sensor (1=B107) detects the wrapping arm turns.

Below sensor (1=B107), the perforated disc rotates at wrapping arm speed.

The permanent change between bore and metal generates a pulse in the sensor (1=B107) which is transmitted to the UNIWRAP module A22.

Test:

- Move wrapping arm to home position.
- This means: A round hole must be below the sensor (1=B107).
- The display now reads: **Wrapping arm pulse: Yes**
- Actuate the wrapping arm manually so that a metal part of the perforated disc is below the sensor (1=B107).
- The display now reads: **Wrapping arm pulse: No** and the LED in the sensor top lights up.

Wrapping arm in home position

Press the key until "Wrapping arm in home position: Yes" appears.

This display appears only when the wrapping arm is in home position.

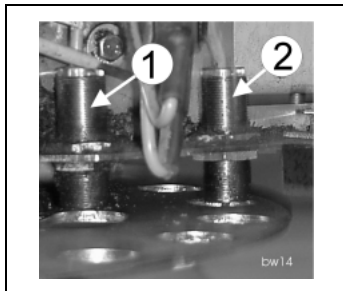

- The display reads: **Wrapping arm in home position: Yes**
- Actuate wrapping arm so that a metal part of the perforated disc is below the sensor (1=B106).
- The display now reads: **Wrapping arm in home position: No** and the LED in the sensor top lights up.

Wrapping table raised

Press the key until "Wrapping table raised: Yes" appears.

- If the wrapping table is lowered (the sensor B105 is not in front of the magnet), the display reads: **Wrapping table raised: No**
- Raise the wrapping table (sensor B105 is in front of the magnet).
- The display reads: **Wrapping table raised: Yes**

Bale on wrapping table

Press the key until "Bale on wrapping table: No" appears.

This display appears only when no bale is on the wrapping table.

The actual value switch (2=Z92) shows if there is a bale on the wrapping table.

The rod (4) is pressed down by the belt of the wrapping table when a bale is on the wrapping table. This motion actuates the actual value switch (2=Z92).

For a rod path of 6.5 ... 9.5 mm, the actual value switch (2=Z92) must change its signal.

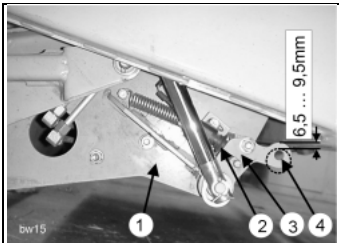
**Test:**

- There is no bale on the wrapping table.
- The display now reads: **Bale on wrapping table: No**
- Actuate the actual value switch (2=Z92) manually or push the rod (4) down.
- The display now reads: **Bale on wrapping table: Yes**

Bale in tipping cradle

Press the key until "Bale in tipping cradle: No" appears.

This display appears only if there is no bale in the tipping cradle.

The sensor (B=B102) detects if a bale is in the tipping cradle.

When the finished bale rolls from the baler onto the lowered tipping cradle, the actuating plate (1) is pressed down.

The magnet is fitted on the inside of the actuating plate (1).

The magnet moves away from the sensor (B=B102) and the sensor signal changes.

The tipping cradle is raised following this signal information.

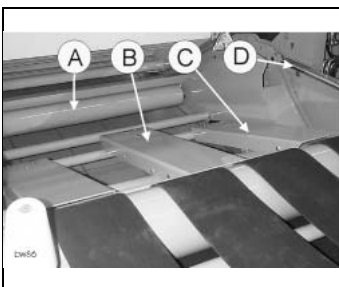
**Test:**

- There is no bale in the tipping cradle.
- The display now reads: **Bale in tipping cradle: No**
- Press down actuating plate (1).
- The display now reads: **Bale in tipping cradle: Yes**

Tipping cradle lowered

Press the key until "Tipping cradle lowered: Yes" appears.

This display appears only when the tipping cradle is lowered.

Sensor (A=B103) detects the position of the tipping cradle.

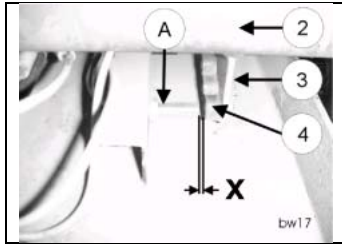

The bracket (3) and therefore the 3 magnets (4) move together with the tipping cradle.

Sensor (A=B103) is fitted to the cover and does not move.

When the tipping cradle is raised the magnets (4) move away from the sensor (A=B103). When the tipping cradle is lowered, the magnets are guided in front of the sensor (A=B103) and the signal changes.

X = 7+-1mm

The tailgate closes following this signal information.

Test:

- Lower tipping cradle.
- The display now reads: **Tipping cradle lowered: Yes**
- Raise tipping cradle.
- The display now reads: **Tipping cradle lowered: No**

Tailgate closed

Press the key until "Tailgate closed: Yes" appears.

This display appears only when the tailgate is closed.

The actual value switch (1=Z16) indicates the tailgate position.

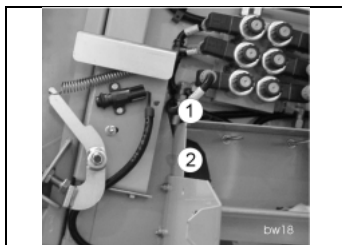

The actual value switch (1=Z16) is located on the right-hand side of the baler. It is actuated by lever (2).

This signal is transmitted to the bale wrapper module A22 via the CAN bus line.

Test:

- Close baler tailgate.
- The display now reads: **Tailgate closed: Yes**
- Press switch.
- The display now reads: **Tailgate closed: No**

Tailgate open

Press the key until "Tailgate open: No" appears.

This display appears only when the tailgate is closed.

The actual value switch (1=Z17) indicates the tailgate position.

The actual value switch (1=Z17) is located on the right-hand side of the baler.

It is actuated by the tailgate cylinder (2).

Tailgate closed = Actual value switch (1=Z17) not actuated

Tailgate open = Actual value switch (1=Z17) actuated

This signal is transmitted to the bale wrapper module A22 via the CAN bus line.

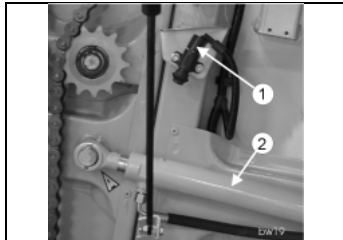
**Test:**

- Close baler tailgate.
- The display now reads: **Tailgate open: No**
- Press switch.
- The display now reads: **Tailgate open: Yes**

Wrapping start signal

Press the key until "Wrapping start signal: No" appears.

Attention: This test cannot be performed.

The wrapper receives the wrapping signal from the baler when the tying is finished.

Wrapping of the bale begins.

Tying start signal

Press the key until "Tying start signal: No" appears.

The wrapper receives the tying start signal from the baler.

Discharge of the wrapped bale starts.

Test:

- The display reads: **Tying start signal: No**
 - Actuate the "Tailgate closed" switch Z16 on the baler.
 - Start tying manually via Rollant Terminal A30.
- The display now reads: **Tying start signal: Yes**

When the display changes, data transmission (via CAN bus) from the baler to the UNIWRAP is o.k.



Press key, display shows home position.

4.0 Fault table

For help in case of malfunctions of the baler consult the Operator's Manual of the baler.

In case of an error message on the UNIWRAP, the following should generally be done:

- **Turn off CCT (CLAAS CONTROL TERMINAL) with emergency off switch.**
The automatic wrapping cycle is now interrupted.
- **Turn CCT on again.**
- Now finish the cycle manually using the UNIWRAP **control box**:

Example:

Move bale from the tipping cradle to the wrapping table:

- Push the switch "Manual control organ Raise/lower tipping cradle" and the corresponding arrow key.
Put down bale on wrapping table and lower the tipping cradle again.
To do so, repeat the following:
- Push the switch "Manual control organ Raise/lower tipping cradle" and the corresponding arrow key.
The bale is on the wrapping table and the tipping cradle is lowered.
Now go back to the CCT (in the tractor) and close the tailgate.
Then you have the following two options to finish the wrapping cycle:
 - 1) Re-start the cycle on the Uniwrap terminal using the top left key or
 - 2) even better (because the driver is already on the tractor near the CCT): Use the CCT menu 5/1 to re-start the wrapping cycle using the "Knotter key".

Malfunctions in the automatic working process are listed below.

Fault	Cause	Remedy
Baler cannot be pushed.	Parking brake applied. Compressed-air brake applied.	Release parking brake. Release brake.
Wrapping process does not start.	Emergency OFF switch on UNIWRAP has been pushed Tipping cradle raised position Bale in tipping cradle Tailgate is not closed	Unlock emergency stop switch Lower tipping cradle Roll bale on wrapping table - Close tailgate - End wrapping cycle with key 
Tailgate does not open Err.: Tailgate	Emergency OFF switch on UNIWRAP has been pushed Wrapping arm not in home position	Unlock emergency stop switch Return wrapping arm in home position
Error message Err.: Bale cradle	Bale not in tipping cradle after 15 sec. Tipping cradle not in lowered position after 10 sec. Error message although bale is in cradle	Roll bale into tipping cradle and continue work sequence by pressing the "START" key Continue work sequence by pressing the "START" key Check sensor
Tipping cradle does not move up or down Err.: Tipping cradle	Emergency OFF switch on UNIWRAP has been pushed Wrapping arm not in home position Incorrect position of tailgate Hydraulic cylinder leaking or defective Wrapping table not raised	Unlock emergency stop switch Return wrapping arm to home position Open tailgate completely Replace and/or repair hydraulic cylinder End wrapping cycle
Tailgate does not close Err.: Tailgate	Bale still in tipping cradle Tipping cradle in raised position Emergency OFF switch on UNIWRAP has been pushed	Roll bale on the wrapping table Lower tipping cradle Unlock emergency stop switch

Fault	Cause	Remedy
Error message Err.: Bale table	Bale is not on the wrapping table 15 s after raising the tipping cradle Bale is still on the table after raising and lowering the wrapping table Error message although bale is on the wrapping table	Continue work sequence by pressing the "START" key Repeat discharge by pressing the "START" and/or "Bale discharge" key Check sensor
Wrapping process interrupted	Safety bow actuated End of film roll Film ripped	Leave tractor and check visually before continuing the work process by pressing the "START" key Insert new film roll Insert film into the film cutter again
Film cutter does not open	Emergency OFF switch on UNIWRAP has been pushed Hydraulic oil flow from the tractor is insufficient or not present.	Unlock emergency stop switch Adjust the hydraulic oil flow on the tractor (see tractor's Operating Manual)
Wrapping table does not move down	Emergency OFF switch on UNIWRAP has been pushed Wrapping arm not in home position No signal "Tying start" from baler	Unlock emergency stop switch Return wrapping arm to home position Wait until baler starts tying
Wrapping table does not move up	Emergency OFF switch on UNIWRAP has been pushed "STOP" key actuated Insufficient hydraulic oil flow from tractor	Unlock emergency stop switch Press "START" key Adjust the hydraulic oil flow on the tractor (see tractor's Operating Manual)
Err: Wrapping table	Wrapping table not raised Check sensor Hydraulic oil flow from the tractor is insufficient or not present.	Raise wrapping table with the key See sensor test Adjust the hydraulic oil flow on the tractor (see tractor's Operating Manual)

Following the policy of CLAAS KGaA mbH to improve their products as technical developments continue, CLAAS reserve the right to make alterations which must not necessarily correspond to text and illustrations contained in this publication, and without incurring obligation to alter any machines previously delivered.

Technical data, dimensions and weights are given as an indication only. Responsibility for errors or omissions not accepted.

Reproduction or translation of this publication, in whole or part, is not permitted without the written consent of the CLAAS KGaA mbH.

All rights under the provision of the Copyright Act are reserved.

CLAAS KGaA mbH
33426 Harsewinkel
Germany



Our contribution to the environment:
CLAAS has printed this manual
on 100 % chlorine free paper.

CLAAS KGaA mbH
Postfach 1163
33426 Harsewinkel
Tel. +49 (0)5247 12-0
www.claas.com

0293 521.0
SYS-D ROLLANT 250-255
EN - 05.05
Printed in Germany

