

## Ⓜ Operator's manual

Nr. 99 337.GB.80E.0

+ INSTRUCTIONS FOR PRODUCT DELIVERY . . . Page 3

---

## **CAT 310 T CR**

(Type PTM 337 : + . . . 01001)

• **Drum mower**



Ihre / Your / Votre • Masch.Nr. • Fgst.Ident.Nr.



## Ⓞ Dear Farmer

You have just made an excellent choice. Naturally we are very happy and wish to congratulate you for having chosen Pöttinger. As your agricultural partner, we offer you quality and efficiency combined with reliable servicing.

In order to assess the spare-parts demand for our agricultural machines and to take these demands into consideration when developing new machines, we would ask you to provide us with some details.

Furthermore, we will also be able to inform you of new developments.

## Important information concerning Product Liability.

According to the laws governing product liability, the manufacturer and dealer are obliged to hand the operating manual to the customer at the time of sale, and to instruct them in the recommended operating, safety, and maintenance regulations. Confirmation is necessary to prove that the machine and operating manual have been handed over accordingly.

For this purpose,

- **document A** is to be signed and sent to Pöttinger,
- **document B** remains with the dealer supplying the machine,
- and the customer receives **document C**.

In accordance with the laws of product liability, every farmer is an entrepreneur.

According to the laws of product liability, property damage is damage caused by a machine and not to it. An excess of Euro 500 is provided for such a liability.

In accordance with the laws of product liability, entrepreneurial property damages are excluded from the liability.

**Attention!** Should the customer resell the machine at a later date, the operating manual must be given to the new owner who must then be instructed in the recommended regulations referred to herein.

<sup>GB</sup> **INSTRUCTIONS FOR  
PRODUCT DELIVERY**

Dokument **D**



ALOIS PÖTTINGER Maschinenfabrik GmbH  
A-4710 Grieskirchen  
Tel. (07248) 600 -0  
Telefax (07248) 600-511  
GEBR. PÖTTINGER GMBH  
D-86899 Landsberg/Lech, Spöttinger-Straße 24  
Telefon (0 81 91) 92 99-111 / 112  
Telefax (0 81 91) 92 99-188

GEBR. PÖTTINGER GMBH  
Servicezentrum  
D-86899 Landsberg/Lech, Spöttinger-Straße 24  
Telefon (0 81 91) 92 99-130 / 231  
Telefax (0 81 91) 59 656

According to the product liability please check the above mentioned items.

Please check.

- Machine checked according to delivery note. All attached parts removed. All safety equipment, drive shaft and operating devices at hand.
- Operation and maintenance of machine and/or implement according to operating instructions explained to the customer.
- Tyres checked re. correct pressure.
- Wheel nuts checked re. tightness.
- Drive shaft cut to correct length.
- Correct power-take-off speed indicated.
- Fitting to tractor carried out: to three-point linkage
- Trial run carried out and no defects found.
- Functions explained during trial run.
- Pivoting in transporting and operating position explained.
- Information given re. optional extras.
- Absolute need to read the operating manual indicated.

In order to prove that the machine and the operating manual have been properly delivered, a confirmation is necessary. For this purpose please do the following:

- sign the **document A** and send it to the company Pöttinger (in case of Landsberg equipment: to the company Landsberg)
- **document B** stays with the specialist factory delivering the machine.  
**document C** stays with the customer.

**Table of contents**

<b>Meanings of warning signs</b> .....	<b>5</b>	<b>Safety points</b> .....	<b>15</b>
<b>Initial connection to tractor</b> .....	<b>6</b>	<b>General maintenance hints</b> .....	<b>15</b>
Electrical equipment: see Supplement .....	6	<b>Repair Instructions</b> .....	<b>15</b>
Check driving motor speed (at the tractor) .....	6	<b>Cleaning of machine parts</b> .....	<b>15</b>
<b>Drive shaft</b> .....	<b>6</b>	<b>MAINTENANCE</b> .....	<b>15</b>
<b>Attachment</b> .....	<b>6</b>	<b>Parking in the open</b> .....	<b>15</b>
Attaching the machine .....	6	<b>Winter storage</b> .....	<b>15</b>
Drive shaft .....	7	<b>Drive shafts</b> .....	<b>15</b>
Connecting the hydraulics .....	7	<b>Hydraulic unit</b> .....	<b>15</b>
Connecting the electrics .....	7	<b>Taper bushes installation instructions</b> .....	<b>18</b>
<b>Changing from work to transport position</b> .....	<b>8</b>	<b>Danger of accident if wearing parts are worn</b> .....	<b>19</b>
1. Before changing to transport position .....	8	<b>Danger of accident if:</b> .....	<b>19</b>
2. Raising the machine .....	8		
3. Swivelling the machine in: Pos T .....	8		
<b>Transporting on public roads</b> .....	<b>8</b>		
<b>Transporting on trailer or lorry</b> .....	<b>8</b>	<b>Lubrication chart</b> .....	<b>20</b>
<b>To operate</b> .....	<b>9</b>		
Important points before starting work .....	9	<b>Technical data</b> .....	<b>24</b>
<b>Adjusting the machine</b> .....	<b>10</b>	<b>Defined use of the mower</b> .....	<b>24</b>
1. Upper link relieving springs (1) .....	10	<b>Position of Vehicle Identification Plate</b> .....	<b>24</b>
2. Adjust cutter bar bearing pressure on main springs (3) .....	10		
<b>Caution when turning on slopes!</b> .....	<b>10</b>	<b>Supplement</b> .....	<b>25</b>
3. Adjusting swath width .....	11	<b>Recommendations for work safety</b> .....	<b>26</b>
4. Adjusting processor angle (Baujahr: - 1997) .....	11	<b>DRIVESHAFT</b> .....	<b>27</b>
5. Intensité de conditionnement (Baujahr: + 1998) .....	11	<b>Preparation</b> .....	<b>30</b>
6. Altering rotor rpm .....	11	Setting required driving motor speed .....	30
<b>Changing from transport to work position</b> .....	<b>12</b>	Turn gearing round .....	30
1. Swivel out .....	12	<b>Power supply</b> .....	<b>32</b>
2. Lower machine .....	12	<b>Installation of control panel</b> .....	<b>32</b>
3. Lower mower unit: retract lifting cylinder (1) completely .....	12	<b>Important! Additional Information</b> .....	<b>34</b>
4. Folding down side guard rails (9) in work position .....	12	<b>Combination of tractor and mounted implement</b> .....	<b>34</b>
5. Adjusting cutting height .....	12		
<b>Placing out of service</b> .....	<b>13</b>		
Parking the machine .....	13		
Electrics .....	13		
Hydraulics .....	13		
Problems when uncoupling .....	13		
Disconnecting drive shaft .....	13		
<b>Swath formation to the side</b> .....	<b>14</b>		
<b>Adjusting swath board</b> .....	<b>14</b>		
<b>Changing to transport position</b> .....	<b>14</b>		
<b>Electrohydraulic operation</b> .....	<b>14</b>		
Control panel operation .....	14		

**CE sign**

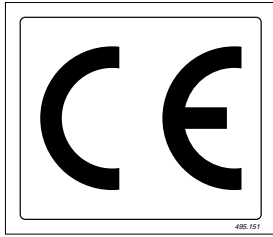

The CE sign, which is affixed by the manufacturer, indicates outwardly that this machine conforms to the engineering guideline regulations and the other relevant EU guidelines.

**EU Declaration of Conformity (see Supplement).**

By signing the EU Declaration of Conformity, the manufacturer declares that the machine being brought into service complies with all relevant safety and health requirements

**Meanings of warning signs**

**Tips for working safety**



Keep away from running motor with p.t.o. connected.



In this operating manual, all positions considered dangerous are identified with this sign.

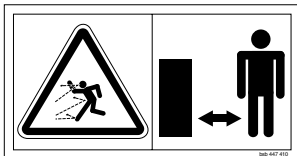

Danger - flying objects; keep safe distance from the machine as long as the engine is running.



Do not touch any moving parts. Wait for complete standstill.

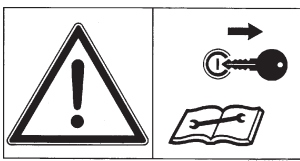

Before maintenance and repair work, switch motor off and remove key.

## Initial connection to tractor

Electrical equipment: see Supplement

Check driving motor speed (at the tractor)

**1000 rpm = standard driving motor speed**

The pivoting gear (SG) has been factory set for operation with this rpm (delivery condition).

**540 rpm**

When only this driving motor speed (540 rpm) is possible on the tractor, the gear (SG) must be removed and installed again in reverse.

- Ensure the drawbar is well supported (e. g. with a solid wooden block "H")!
- Remove oil filler neck.

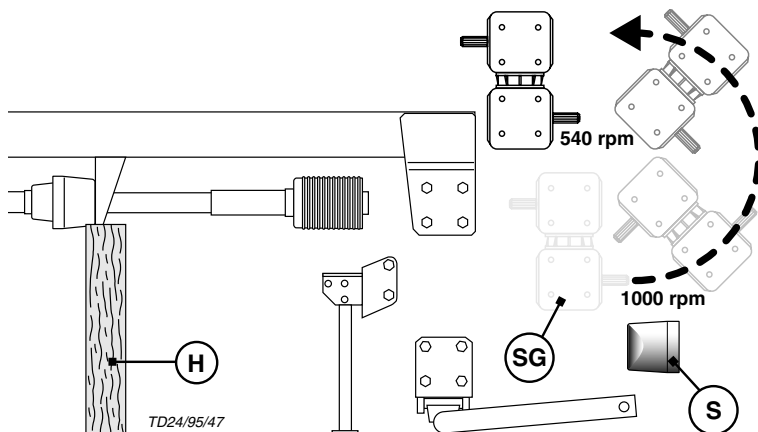

- Then install protective cap again.
- For further details see chapter "REVERSING THE GEAR" in the supplement.

## Drive shaft

Use correct drive shaft

- Type W 2500 for a drive motor speed of 540 rpm
- Type W 2400 for a drive motor speed of 1000 rpm

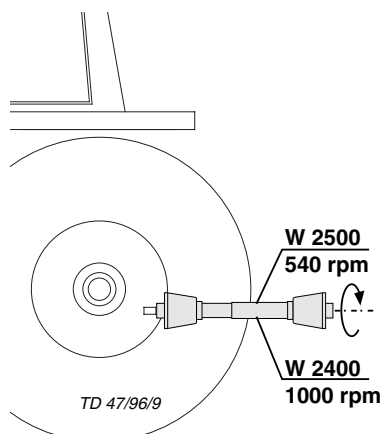

## Attachment



- **Safety advice: see Supplement A1, points 1 - 8.**
- **Check that cutter screws and processor tines are firmly seated.**
- **Against unsteady, unstable machine after-run:**

- Secure lower hydraulic link (U) so that implement cannot swing out sideways.

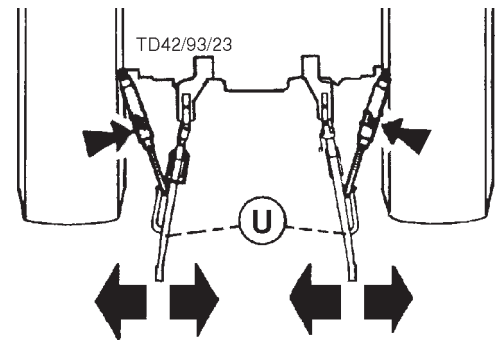

## Attaching the machine

- Starting position:  
Park machine on the support stand (7) on level ground with bolts (8) inserted and spring pin (10) secured.
- Attach lower link to the pipe bottom (9) and lock at this height:  
The attaching height corresponds to the parking height on firm ground.

## Fold support wheel (7) up: Pos. O

- Pin jack stand (7) up using bolts (8) and secure with spring pin (10).

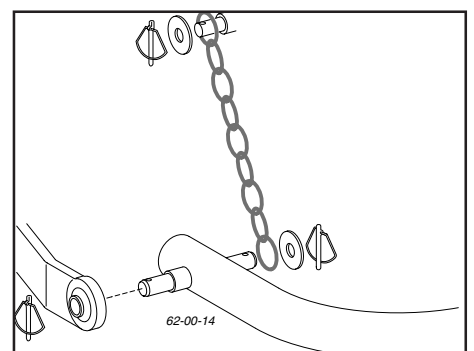
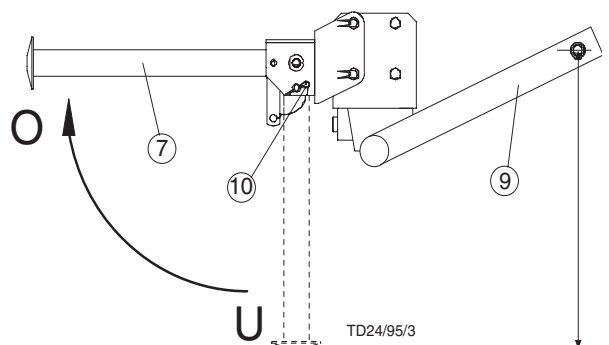

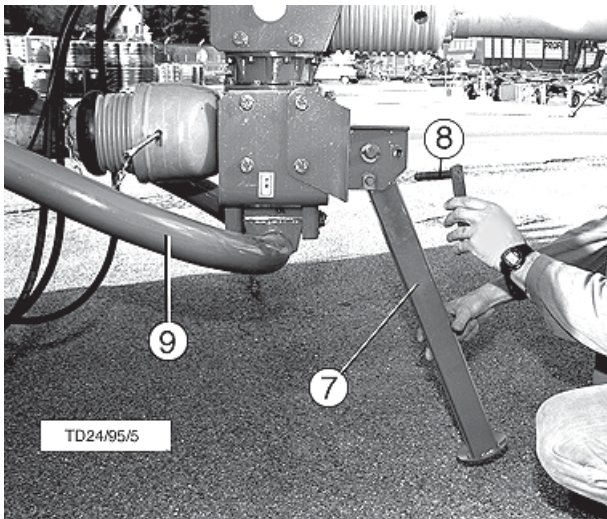

- Raise support stand (7) insert bolt (8) in upper hole and secure with spring pin (10)

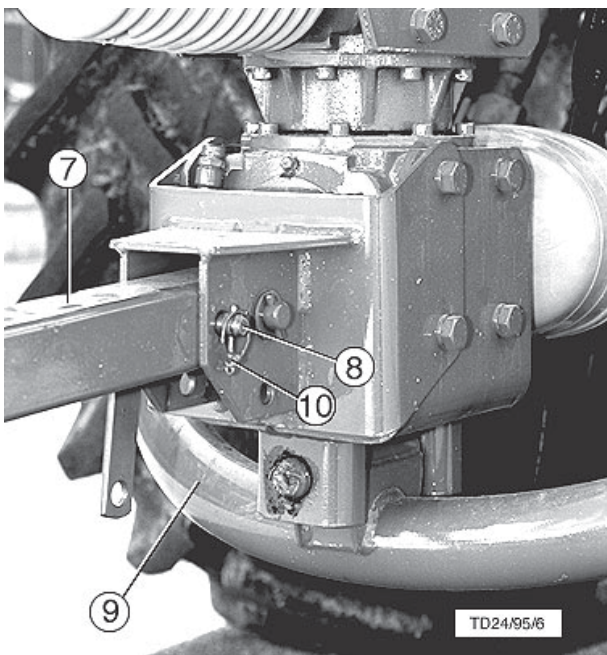

**Drive shaft**

- Check drive shaft length before initial operation and adapt if necessary. See chapter „DRIVE SHAFT“ also in Supplement B, or the accompanying drive shaft instruction manual.

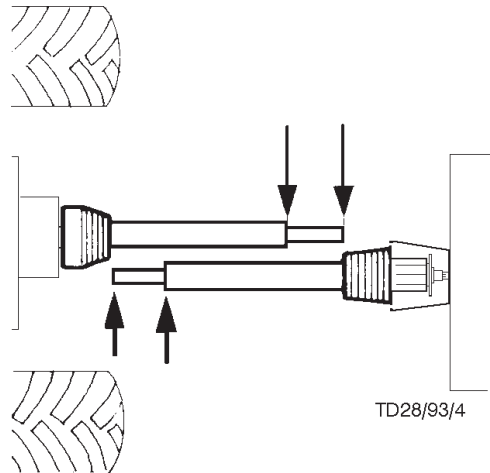

**Connecting the hydraulics**

- At least one double-action (11) and one single-action (10) hydraulic connection must be available on the tractor.
- Connect hydraulic lines to tractor:
  - Feed hydraulic lines through cable routing (13).
  - Insert plug-in connections of hydraulic lines.

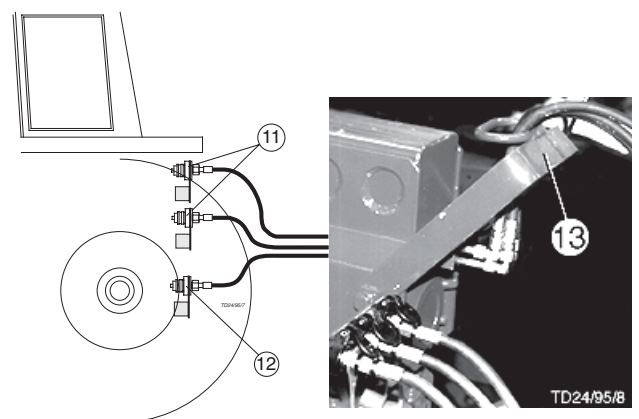

**Connecting the electrics**

- Feed cable through cable routing (13).
- Connect.

## Changing from work to transport position



- **Safety advice:** see Supplement A1, pts. 1, 3, 4 and 6-9.

### 1. Before changing to transport position

- Turn p.t.o. off and wait for cutter to completely stop (mower runs after turning off for approx. 30 seconds)

### 2. Raising the machine

- Raise mower: extend lifting cylinder (1) completely out.
- **Lock (year of construction -1998)**
  - Remove spring pin (2).
  - Fold locking device (3) up: Pos. O
  - Secure with spring pin.
- **Lock (year of construction +1999)**
  - Swing lever into position T1

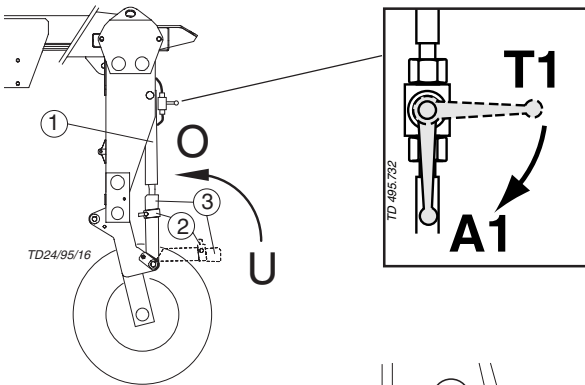

### 3. Swivelling the machine in: Pos T

- Retract swivelling cylinder completely.
- **Lock (year of construction +1999)**
  - Swing lever into position E2

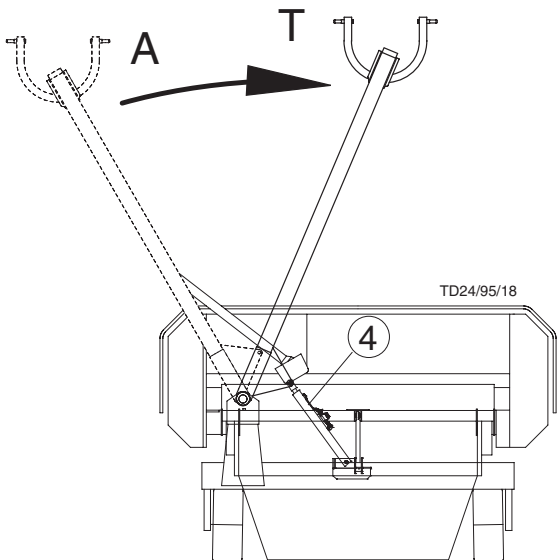
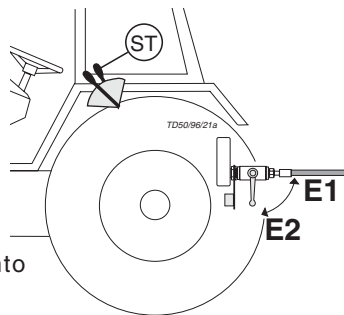

## Transporting on public roads



- **Safety advice:** see Supplement A1, pts. 1, 3, 4 and 6-9.

- **Unfallgefahr durch unbeabsichtigtes Ausschwenken der Maschine während der Fahrt.**
  - Bei Straßenfahrt mit eingeschwenkter Maschine den Hydraulikkreis immer sperren (Hebel in Pos. E2).

- Travel on public roads only in transport position!
- Side guard rails (5):
  - Remove linch pin (6).
  - Fold guard rail up.
  - Secure with linch pin.
- Check lighting and safety equipment.

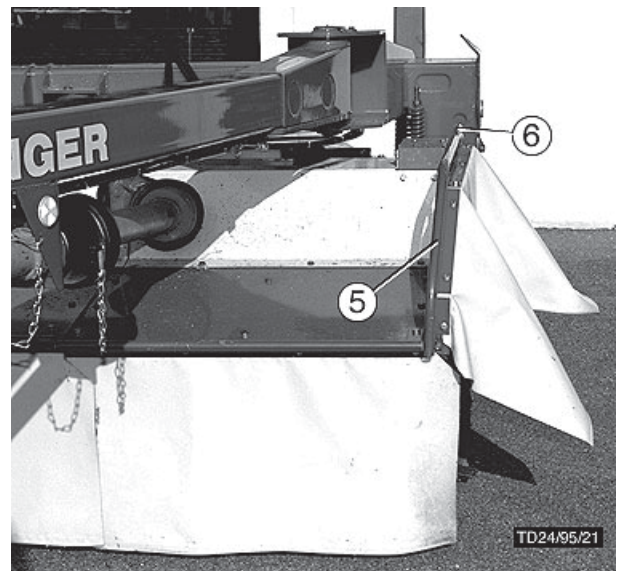
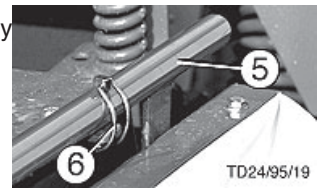

## Transporting on trailer or lorry

- Fit in spacers (right 14,5 cm, left 11 cm).
- Swivel drawbar in and fix it (F).

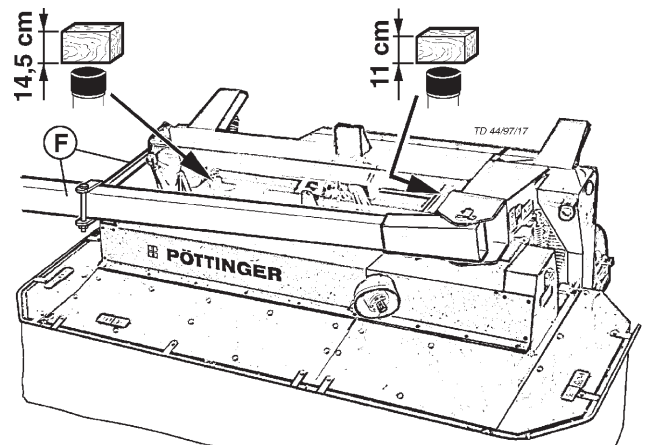

## To operate

### Important points before starting work



• **Safety advice:**  
see Supplement A1, pts. 1-4 and 6-8.

#### 1. Check:

- Check wear of blade bolt (31).  
Replace blade holder when bolt diameter is less than 9 mm.
- Check blade holder (30) on damage.

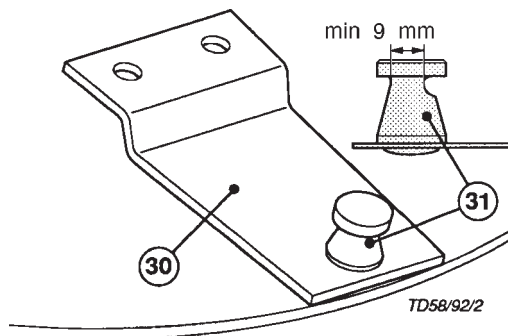

- In case of grinding noises check whether the blade holder (30) is buckled and therefore the blade does not lie correctly any more.

#### 2. Only turn machine on when in work position and do not exceed the stipulated p.t.o. r.p.m. according to gearing fitted: 540 or 1000 r.p.m.!

- In principle, only turn p.t.o. on when all safety equipment (covers, protective aprons, facings, etc.) are in proper order and are in their protective position on the implement.

#### 3. Ensure the correct p.t.o. rotation direction! If rotation direction is wrong then the drive runs empty in the drive shaft free-running.

#### 4. Prevent damage!

- The area to be mowed must be free of obstacles or foreign bodies. These (e.g. rocks, pieces of wood, boundary markers, etc.) can damage the mowing unit.



#### Should a collision occur

- Stop immediately and turn drive off.
- Check machine carefully for damage.
- Let a specialist work shop make an additional check if necessary.

#### 5. Keep away when motor is running

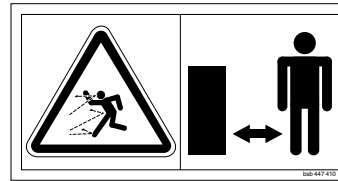

- Keep people out of the danger area as injury can occur through out-thrown foreign bodies.

Take particular care on stoney fields, and near roads and paths.

#### 6. Wear hearing protection



The noise level in the working place can differ from the measured values (see Technical Data), particularly through the various designs of the different tractor cabins.

- When a noise level of 85 dB(A) is reached or exceeded, then the employer (farmer) must have suitable hearing protection available (UVV 1.1 §2).
- When a noise level of 90 dB(A) is reached or exceeded, then hearing protection must be worn (UVV 1.1 § 16).

#### 7. Check condition of V-belts

Replace worn out or damaged V-belts!

#### 8. Check V-belt tension!

The disc on the pressure spring should be set at the top control measurement. Adjustment takes place by turning the adjusting nut accordingly. Secure again with the locking nut afterwards (see chapter "Maintenance and Service").

#### 9. To mow, slowly throw-in the p.t.o. away from the forage to be mowed and bring the mowing drum up to full speed.

An even continuous increase in r.p.m. prevents operating noises in the drive shaft free-running.

- The speed of travel depends on the terrain and forage to be mowed.

**Caution when turning on slopes!**



**Danger of tipping exists**

- when turning left
- when mower unit is positioned downhill

**Safety advice**

- Mount accompanying ballast weights onto left wheel bearer of mower unit (these components are optional with some types, see Spare Parts List also)
- When turning left reduce speed accordingly.
- Travel with mower unit positioned uphill.
- It is better travel in reverse on a slope than to make a risky turn.

**Adjusting the machine**

**1. Upper link relieving springs (1)**

- Improve cutter unit adaption to ground contours.
- Are preset in the factory.
- Inside measurement of the German rings

**2. Adjust cutter bar bearing pressure on main springs (3)**

- Preset in the factory: 150 kg
- left: 75 kg
- right: 75 kg

**Fixed measurement console spring:**

- left: L1
- right: R1
- Decrease bearing pressure: turn screw (4) to the right.
- Increase bearing pressure: turn screw to the left.

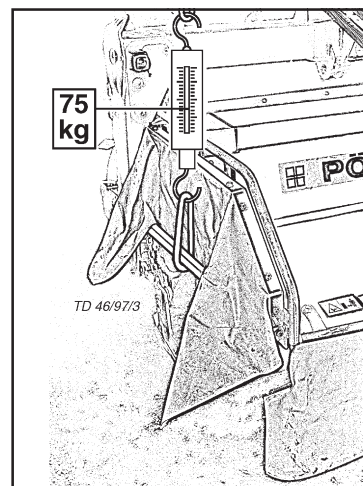
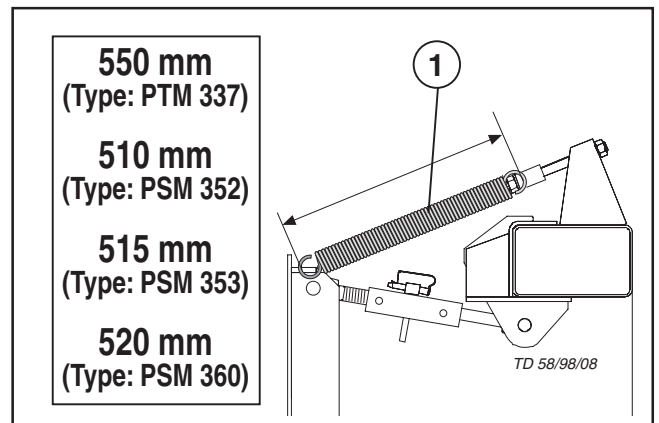

	L1 (mm)	R1 (mm)
<b>CAT 310 T</b> (Type: PTM 337)	140	190
<b>CAT NOVA 260 T</b> (Type: PSM 352)	190	230
<b>CAT NOVA 310 T</b> (Type: PSM 353)	160	200
<b>CAT NOVA 360 T</b> (Type: PSM 360)	88	130

### 3. Adjusting swath width

- Loosen swath board (12) with clamping lever (13).
- Adjust swath board by shifting clamping lever.
- Secure.

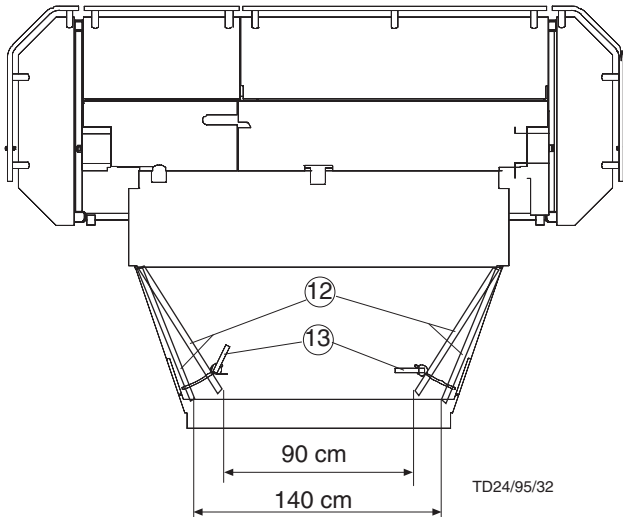

### 4. Adjusting processor angle (Baujahr: - 1997)

- Turn lever (14) to the right. This brings impact plate (15) closer to processor tines.
- Turn lever to the left. Impact plate is further away. The distance between the impact plate and processor tines can change the conditioning effect.
- Conditioning is most efficient in the lowest position (-), the forage surface is intensively worn down but it should not be beaten.
- The opposite effect is the case for the highest position (+) as the forage surface is only lightly worn down.

The correct setting depends on the volume of forage, speed and tractor power among other things.

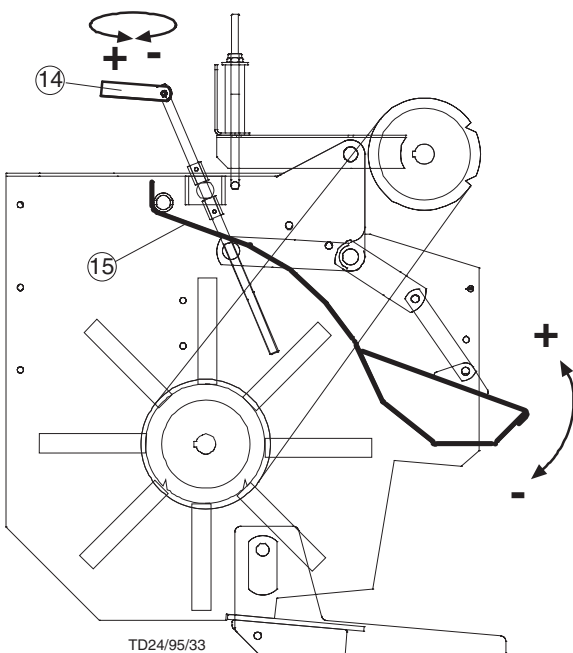

### 5. Intensité de conditionnement (Baujahr: + 1998)

Le levier de réglage modifie la distance entre le rotor et le volet. Ceci fait varier l'intensité du conditionnement.

- En position basse (5), on obtient l'intensité maximale. La couche extérieure des plantes sera le plus travaillée. Mais veiller à ne pas broyer le fourrage.
- A l'opposé, en position haute (0), le fourrage ne sera que peu conditionné.

Le réglage idéal est fonction de la densité du fourrage, de la vitesse d'avancement et de la puissance tracteur. Pour cette raison, nous ne pouvons pas donner d'indication précise sur la position idéale de ce levier de réglage.

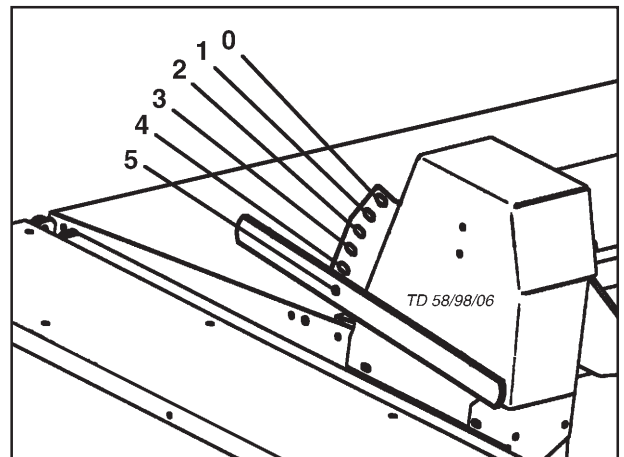

### 6. Altering rotor rpm

- by exchanging pulley (A) and belts (B).  
Parts: see Spare Parts List

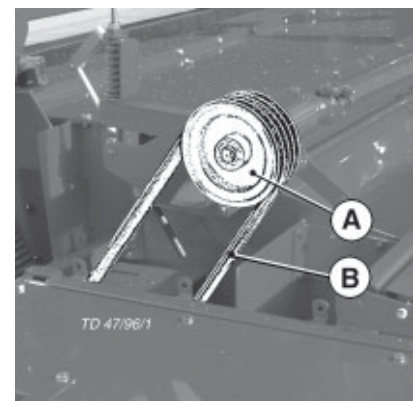

- **Low: 630 rpm**
  - pulley with  $\varnothing$  147 mm

This rpm is recommended for very leafy forage because it is not intensively crushed.
- **High: 860 rpm**
  - pulley with  $\varnothing$  197 mm

These prepare forage for quick drying. But forage should not be crushed.
- **High: 1000 rpm**
  - pulley with  $\varnothing$  224 mm

## Changing from transport to work position



- **Danger of injury from out-swinging machine:**
- Note free swivel area.

### 1. Swivel out

- Extend swivel cylinder (5) completely out: Pos. A

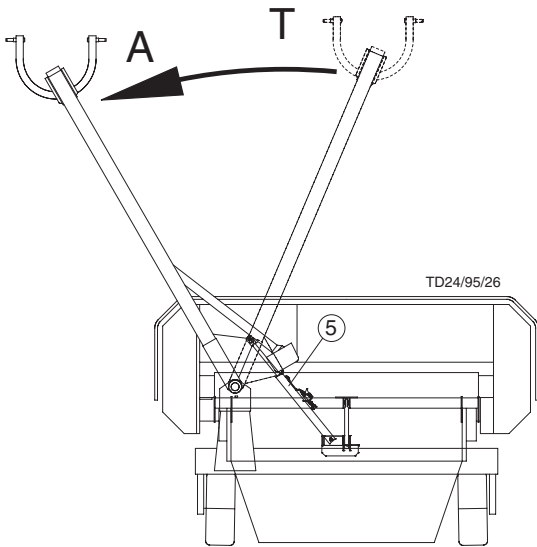

### 2. Lower machine

- **Unlock on both sides (year of construction -1998):**
  - Remove spring pin (2).
  - Fold locking mechanism (3) down: Pos. U
  - Secure with spring pin.
- **Unlock on both sides (year of construction +1999)**
  - Swing lever into position A1

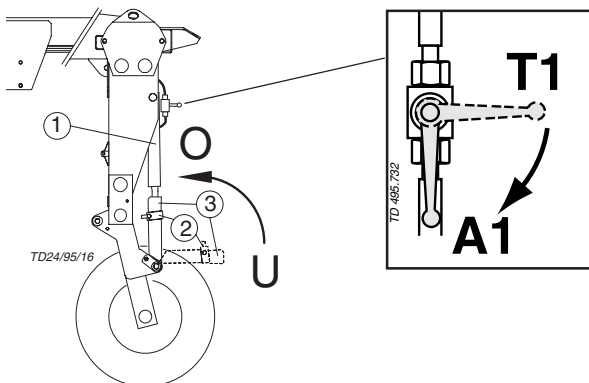

### 3 Lower mower unit: retract lifting cylinder (1) completely.

### 4. Folding down side guard rails (9) in work position

- Remove linch pin (10).
- Fold down guard rail.

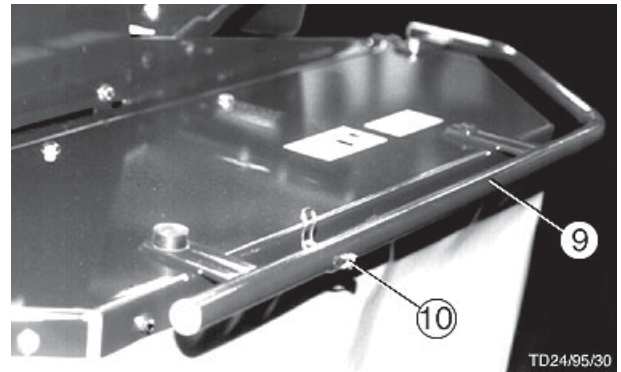
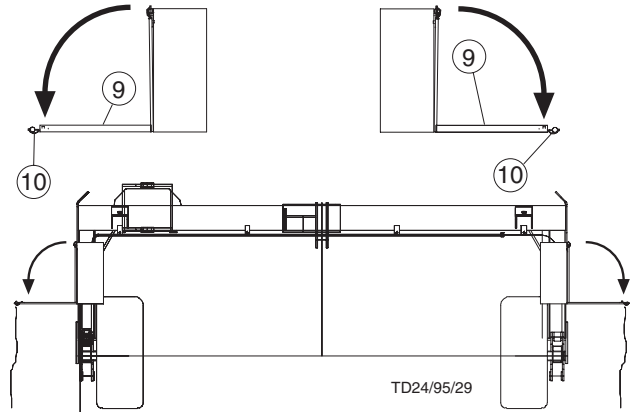

## 5. Adjusting cutting height

**Setting:** Lift mower unit hydraulically (H1)

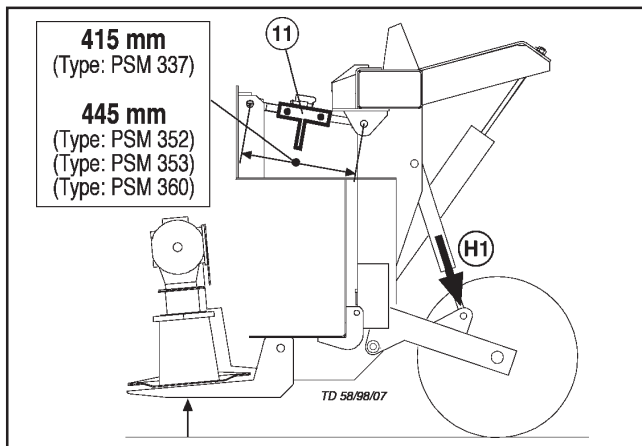

- For optimum operation the set measurement for the telescopic upper link should be 415-445 mm: see drawing (Type)
- Increase:
  - Turn telescopic upper link (11) to the right.
- Decrease:
  - Turn telescopic upper link to the left.

## 5. Adjust cutting height with runner (only with CAT NOVA)

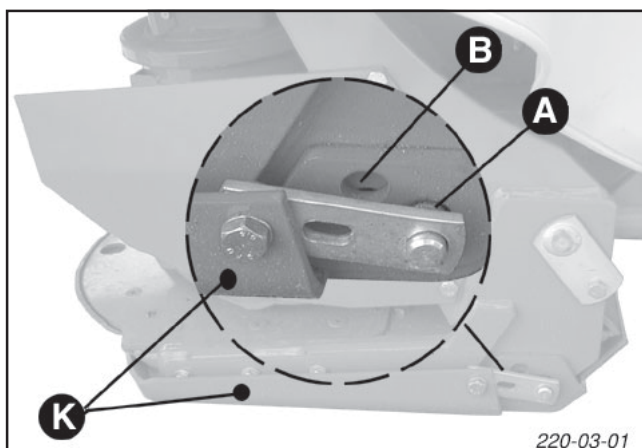

- The cutting height can be moved to 2 positions using the runner (K)
- Pos. "A" low, pos. "B" high

## Placing out of service



- **Safety advice: see Supplement A1, pts. 1 and 8**

- **Park machine only on firm level ground.**

### Parking the machine

- Remove spring pin from support stand.
- Swing support stand (8) down and secure: Pos. U
- Insert bolt (9) and secure with spring pin (10)
- Lower onto support stand using tractor's hydraulics.

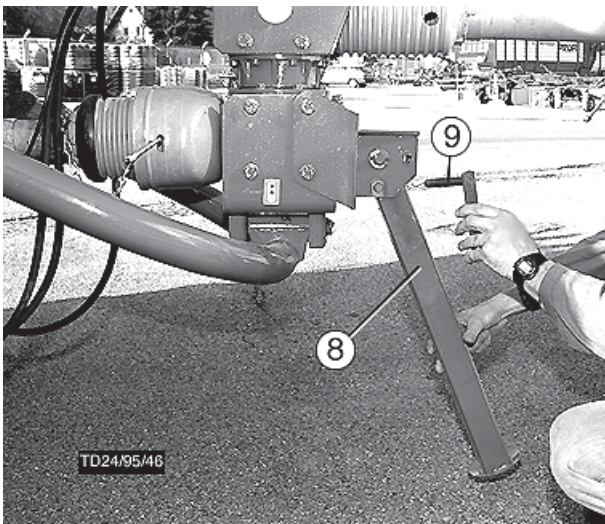
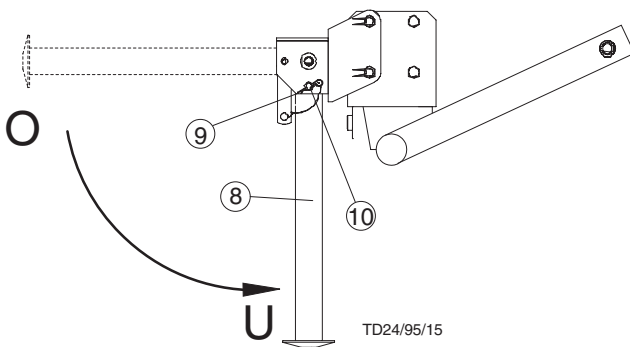

### Electrics

- Pull out plug.

### Hydraulics

- Disconnect hydraulic lines from tractor and insert into holder.

### Problems when uncoupling

- To reduce remaining pressure: position servo-valve briefly at „lower (S)“.
- Uncouple hydraulic lines.

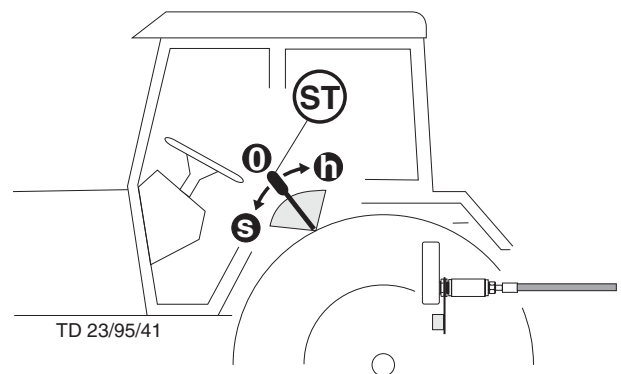

### Disconnecting drive shaft

- Turn motor off.
- Turn p.t.o. off.
- Wait for standstill: The mowing unit runs for about 30 seconds after being shut off.
- Disconnect drive shaft

### Uncouple lower link attachment.

## Swath formation to the side



- **Danger of accident when swinging the machine out:**
- Pay attention to free swivelling range.
- Crushing and cutting points within swivelling range of swath board.

## Adjusting swath board

1. Swing drawbar out into working position
2. Then actuate the servo-valve (ST)
  - Swing swath board into position for swath

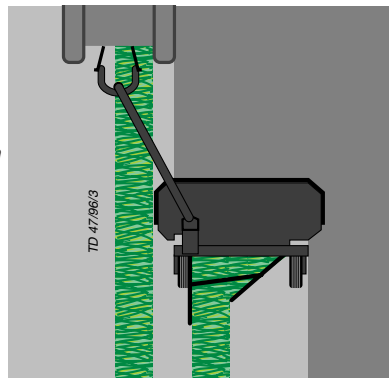
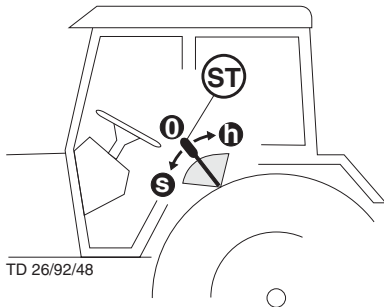

**Swath formation - left**  
- Lever in "LA" position

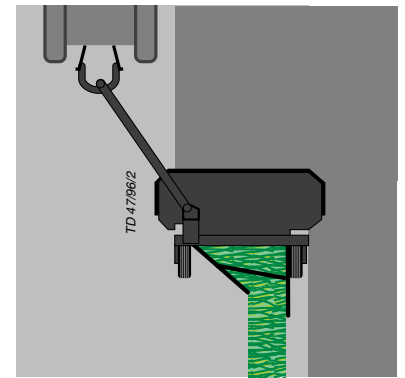

**Swath formation - right**  
- Lever in "RA" position

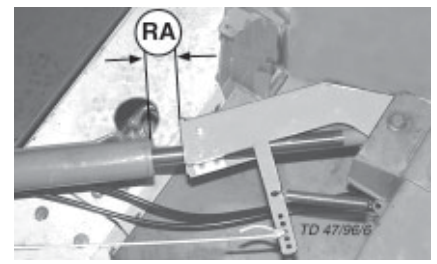
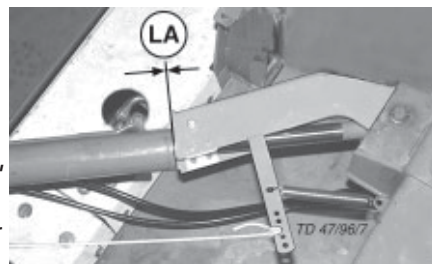

- formation - right
- Lever in "RA" position

3. Move servo-valve (ST) to "LOWER" (s)

- Swing swath board into position for swath formation - left
- Lever in "LA" position

**Transport position**  
- Lever in "TR" position

## Changing to transport position

1. Pull rope (S)
  2. Move servo-valve (ST) to "LOWER" (s)
    - Drawbar swings into transport position
    - Release rope (S)
- Lever in "TR" position

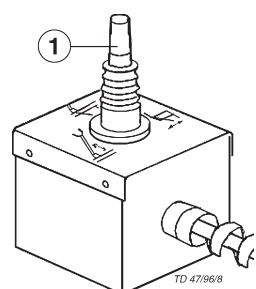
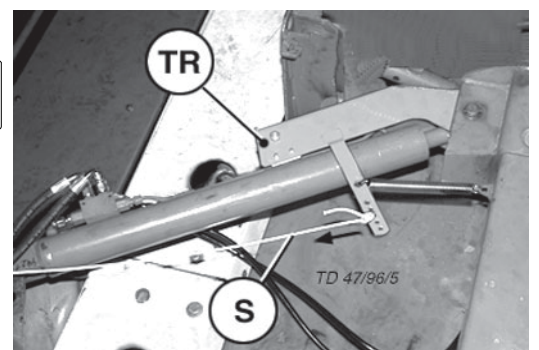
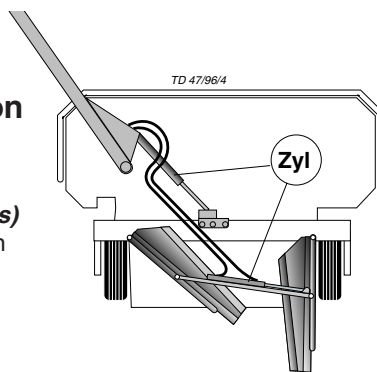

## Electrohydraulic operation

- Control panel operation**
- Pre-select required control panel function (1)
  - Actuate servo-valve (ST)

Swing drawbar

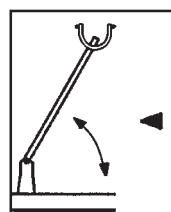

Swing drawbar and swath board

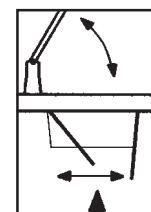

Swing swath board

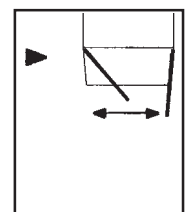

### Safety points

- Turn engine off when adjustment, service and repair work is to be done.
- Do not work under the machine without safe support.
- Retighten all screws after the first hours of operation.



### General maintenance hints

In order to keep the implement in good condition after long periods of operation, please observe the following points:

- Tighten all screws after the first hours of operation.

#### In particular check:

- blade screws on the mowers
- tine screws on the swather and tedder.



#### Spare part

- The **original components and accessories** have been designed especially for these machines and appliances.
- We want to make it quite clear that components and accessories that have not been supplied by us have not been tested by us.
- The installation and/or use of such products can, therefore, negatively change or influence the construction characteristics of the appliance. We are not liable for damages caused by the use of components and accessories that have not been supplied by us.
- Alterations and the use of auxiliary parts that are not permitted by the manufacturer render all liability invalid.

### Repair Instructions



Please refer to repair instructions in supplement (if available)

### Cleaning of machine parts

**Attention!** Do not use high-pressure washers for the cleaning of bearing- and hydraulic parts.

- Danger of rust!
- After cleaning, grease the machine according to the lubrication chart and carry out a short test run.
- Cleaning with too high pressure may do damage to varnish.

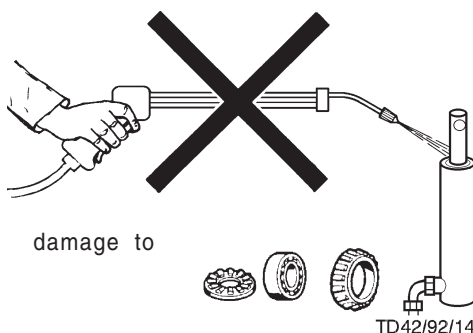

### Parking in the open

When parking in the open for long periods of time, clean piston rods and then coat with grease.

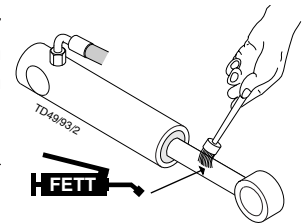

### Winter storage

- Thoroughly clean machine before storage.
- Put up protection against weather.
- Change or replenish gear oil.
- Protect exposed parts from rust.
- Lubricate all greasing points according to lubrication chart.

### Drive shafts

- see notes in the supplement
- For maintenance please note!**

The instructions in this operating manual are always valid.

In case there are no special instructions available, then the notes in the accompanying drive shaft manufacturer's instructions are valid.

### Hydraulic unit

#### Caution! Danger of injury or infection!

Under high pressure, escaping fluids can penetrate the skin. Therefore seek immediate medical help!

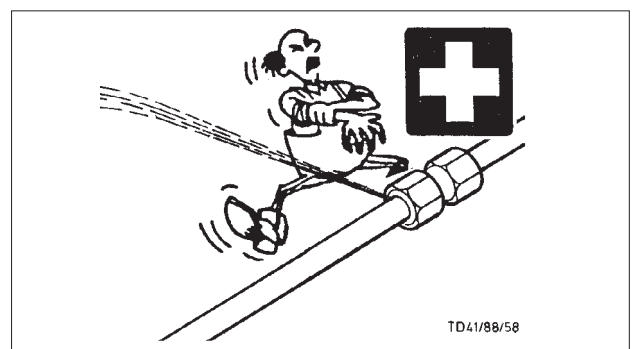

#### After the first 10 operating hours and then every consecutive 50 operating hours

- Check the hydraulic unit and lines for tightness and retighten screw connections if necessary.

#### Before operation

- Check hydraulic hoses for wear.

Replace worn or damaged hydraulic hoses immediately. The replacement hoses must meet the manufacturer's technical requirements.

### Gearing

- Change oil after the first 50 hours of operation.
- Under normal operating conditions, oil is to be topped-up annually.
- Change oil after 300 ha at the latest.

### Cutter bar-oil change

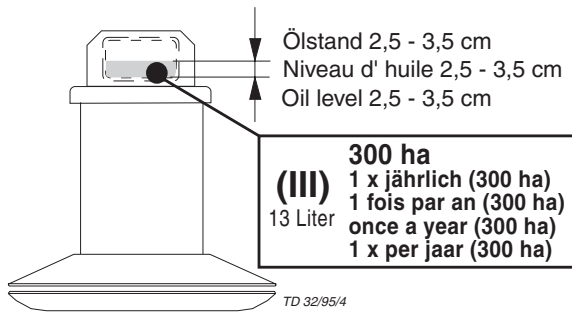

### Cutters



*The cutters on a cutting drum should be evenly worn out, (danger of imbalance) otherwise they are to be replaced by new ones.*

### Pay attention to correct assembly!

- Cutters with the notation "L" are only to be mounted on the left rotating mowing drum.
- Cutters with the notation "R" are only to be mounted on the right rotating mowing drum.

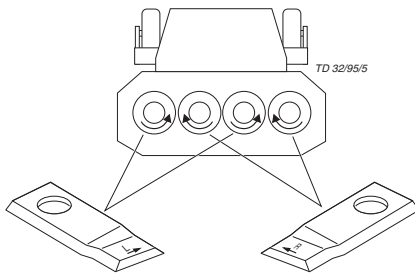

### Changing the cutters

- Prop up the lever (29) on the lower edge of the drum and push the moveable holder (30) downwards. The cutter (14) is hung on the bolt (31).
- Change the cutters and clean all forage away that the cutter held from around the bolt. Perhaps the inner side of the drum also.
- Remove the lever (29) and check if the cutter holder bolt (31) has returned to its original position and if the cutter can move freely on the bolt.
- When the bolt (31) is greatly worn, the holder (30) should be replaced.

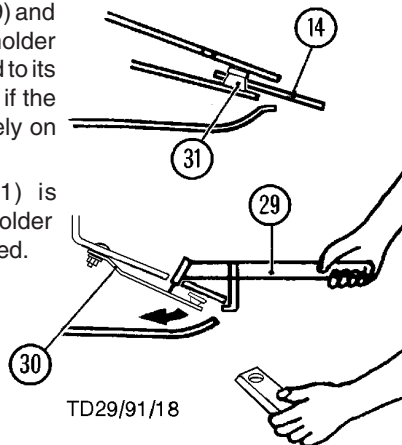

### Checking the mowing blade suspension

- Check immediately after driving over a hard obstacle.
- Normal check every 100 hours.
- Check more often when mowing on rocky terrain.

### Mower disc

**With mower discs that are worn in the mowing blade area, you must proceed as follows:**

- Remove lower support disc.
- Kunststoffklappe entfernen.
- Remove cutter holder nuts.
- Shift cutter holder around 1 hole (60°).
- Tighten screws firmly (120Nm) and re-check after a few hours of operation.
- Re-mount mowing blades.

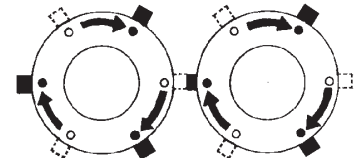
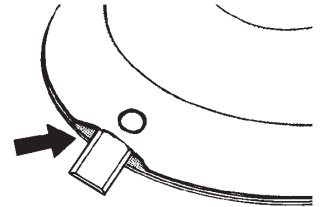

### V-belt tension

**After the first hours of operation**

- Check or adjust V-belt tension:  
After changing V-belts:  
Basic adjustment:  
- Disc (1) to approx. top control measurement (2).  
- Secure with lock nut (3).

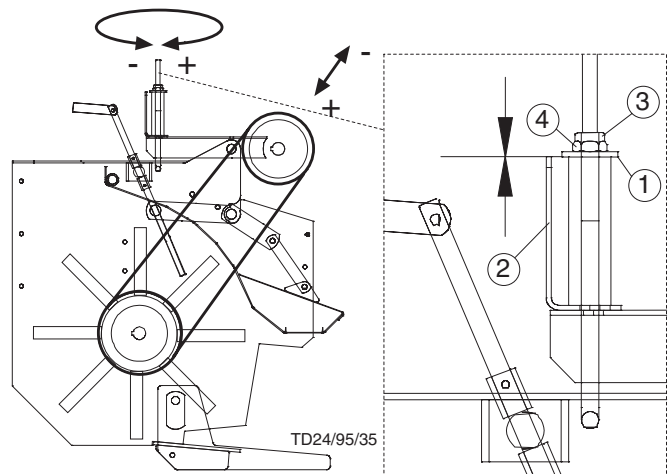

### WINTER STORAGE

- Driving belts should be slackened throughout the winter.

### Gearing

- Change oil after the first 50 hours of operation.
- Under normal operating conditions, oil is to be topped-up annually.
- Change oil after 300 ha at the latest.

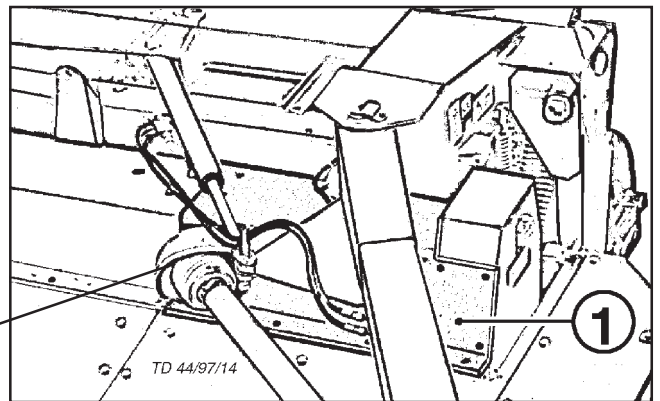

### Starting transmission

**Fill with oil:**

Full amount: 1,6 litres: SAE 90

- Remove shield (1).
- Take out oil drain plug (62), let run out and duly dispose waste oil.
- Take out oil filler plug (5) and top up oil "SAE 90" up to the level screw (OIL LEVEL).

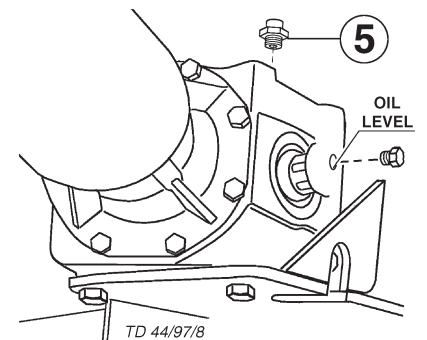
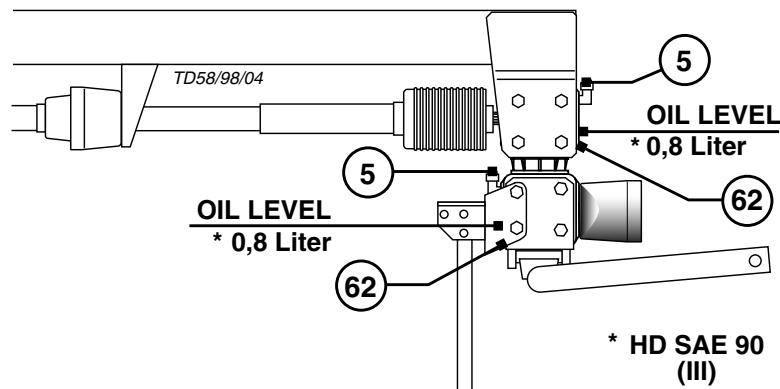
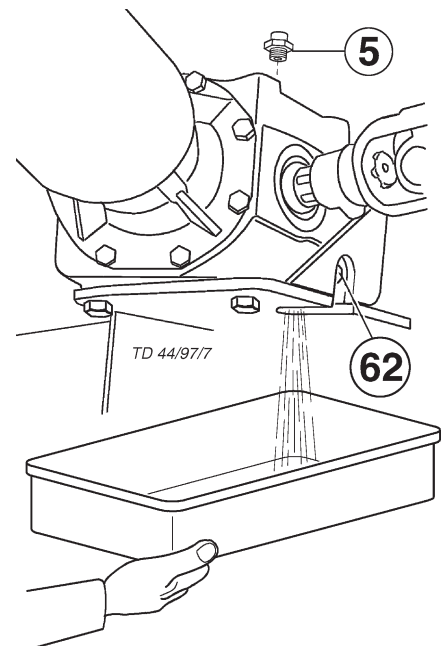
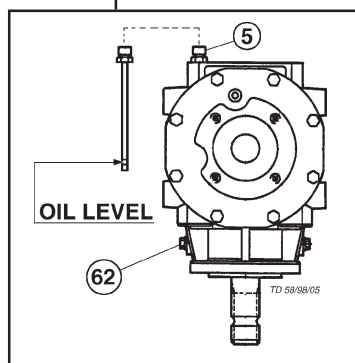
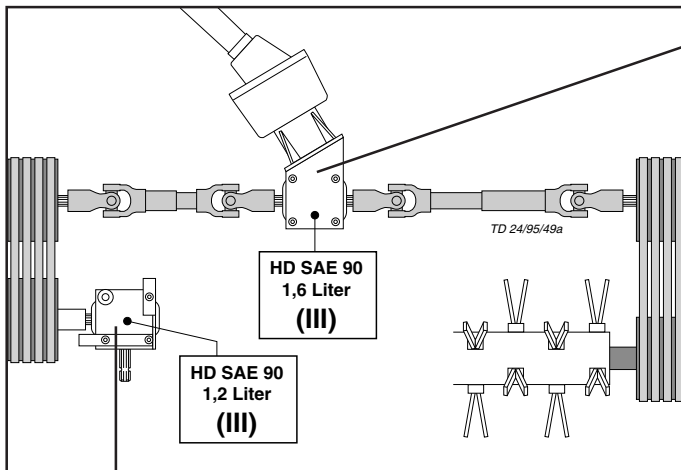

## Taper bushes installation instructions

### To assemble

1. Clean and degrease the bore and taper surfaces of the bush and the tapered bore of the pulley.
2. Insert the bush in the pulley hub and line up the holes (half thread holes must line up with half straight holes).
3. Lightly oil the grub screws (bush size 1008 to 3030) or the cap screws (bush size 3535 to 5050) and screw them in, do not tighten yet.
4. Clean and degrease the shaft. Fit pulley with taper bush on shaft and locate in desired position.
  - When using a key it should first be fitted in the shaft Keyway. There should be a top clearance between the key and the keyway in the bore.
  - Using a hexagon socket wrench (DIN 911) gradually tighten the grub/cap screws in accordance with the torques as listed in the schedule of screw tightening torques (48 Nm, 90 Nm).
  - When the drive has been operating under load for a short period (half to on hour) check and ensure that the screws remain at the appropriate tightening torque.
  - In order to eliminate the ingress of dirt fill all empty holes with grease.

### Removal

1. Slacken all screws. Depending on the size of the bush remove one or two. After oiling point and thread of grub screws or under head and thread of cap screws insert them into the jacking off hole(s) in bush (Pos. 5).
2. Tighten screw(s) uniformly and alternately until the bush is loose in the hub and pulley is free on the shaft.
3. Remove pulley bush assembly from shaft.

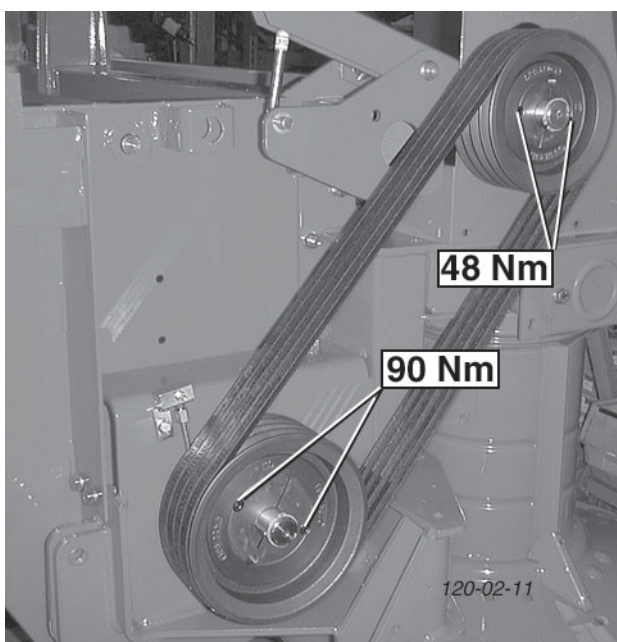
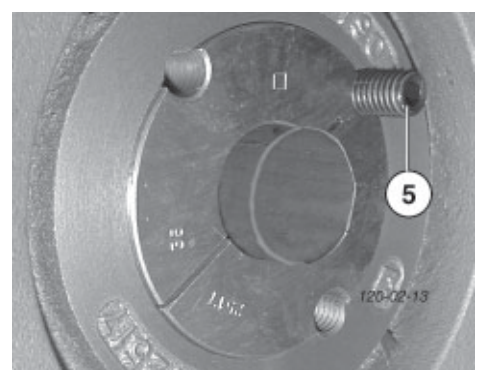
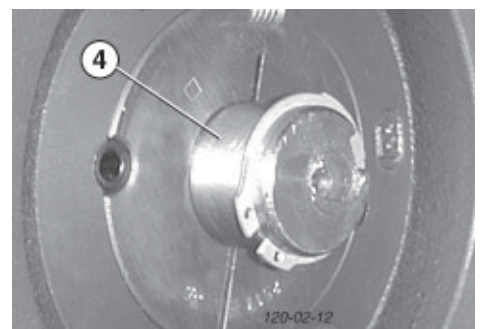
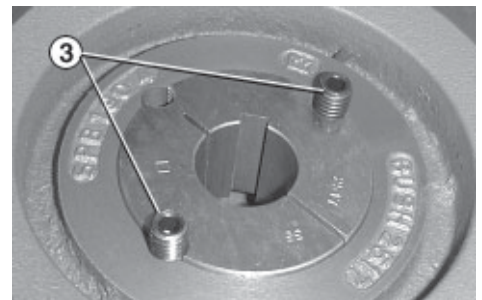
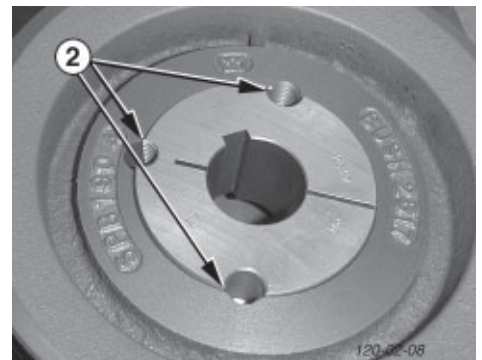
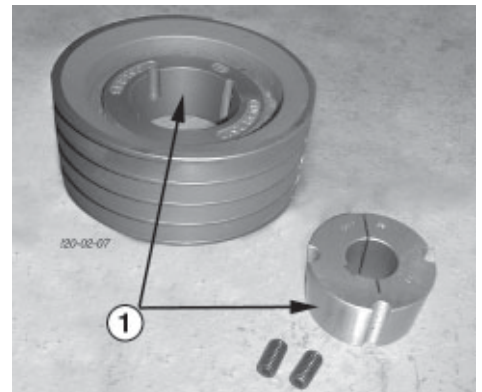

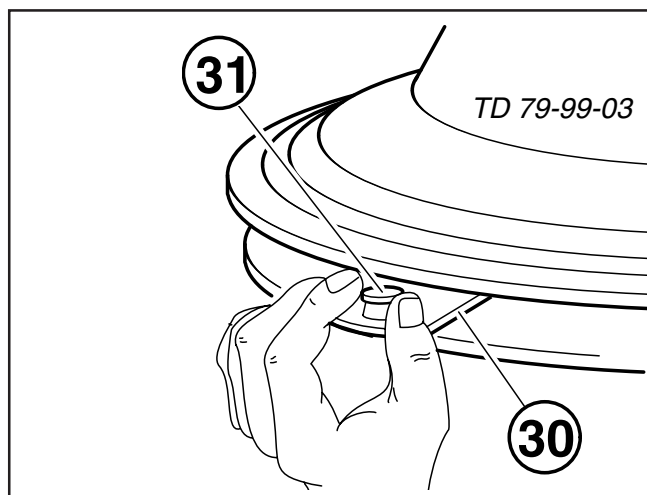
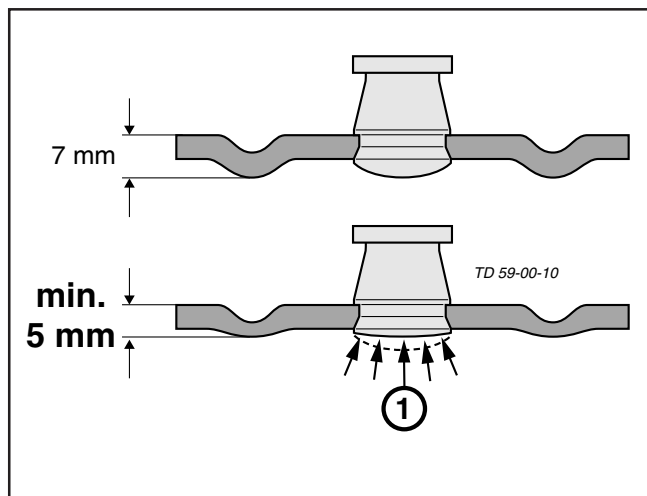
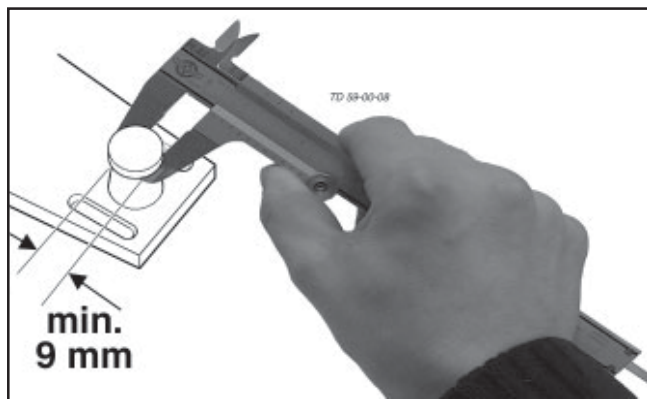
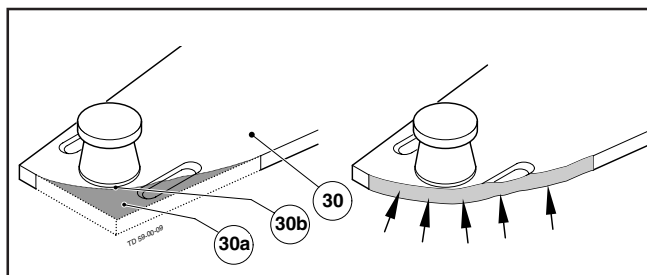

## Attention !

### Danger of accident if wearing parts are worn

#### Wearing parts are:

- mounting of mowing blades (30)
- bolts of mowing blades (31)



If such wearing parts are worn out they must not be used any longer, otherwise it can no longer be guaranteed that the pin of the mowing blade is firmly adjusted and accidents may be caused through parts that are flung away (e.g. mowing blades, fragments...)



#### Check the suspension of mowing blades as to wear and other damage:

- every time before bringing the machine into operational use
- several times during use
- immediately after hitting an obstacle (e.g. a stone, piece of wood, metal,...)

#### Process of visual control:

1. remove mowing blades
  2. remove grass and dirt
- around pin (31)

## Attention !

### Danger of accident if:

- the wearing area (30a) is worn up to the pin of the mowing blade (30b)
- the pin diameter is 9 mm or less
- the profile is only 5 mm or less (original measure = 7 mm)
- the riveted joint (1) of the pin is worn
- the pin (31) of the blade is no longer firmly seated



If you notice one or several of these characteristics of wear stop mowing at once! Worn parts must be replaced by original parts made by Pöttinger immediately !

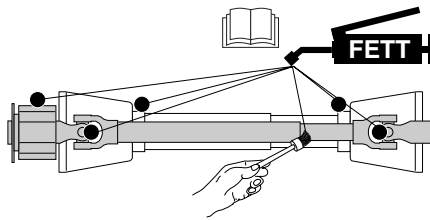

### D Schmierplan

8 <sup>h</sup>	alle 8 Betriebsstunden
20 <sup>h</sup>	alle 20 Betriebsstunden
40 F	alle 40 Fahren
80 F	alle 80 Fahren
1 J	1 x jährlich
100 ha	alle 100 Hektar
FETT	FETT
▽	= Anzahl der Schmiernippel
(IV)	Siehe Anhang "Betriebsstoffe"
Liter	Liter
*	Variante
	Siehe Anleitung des Herstellers

### F Plan de graissage

8 <sup>h</sup>	Toutes les 8 heures de service
20 <sup>h</sup>	Toutes les 20 heures de service
40 F	Tous les 40 voyages
80 F	Tous les 80 voyages
1 J	1 fois par an
100 ha	tous les 100 hectares
FETT	GRAISSE
▽	= Nombre de graisseurs
(IV)	Voir annexe "Lubrifiants"
Liter	Litre
*	Variante
	Voir le guide du constructeur

### GB Lubrication chart

8 <sup>h</sup>	after every 8 hours operation
20 <sup>h</sup>	after every 20 hours operation
40 F	alle 40 operations
80 F	alle 80 operations
1 J	once a year
100 ha	every 100 hectares
FETT	GREASE
▽	= Number of grease nipples
(IV)	see supplement "Lubricants"
Liter	Litre
*	Variation
	See manufacturer's instructions

### NL Smeerschema

8 <sup>h</sup>	alle 8 bedrijfsuren
20 <sup>h</sup>	alle 20 bedrijfsuren
40 F	alle 40 wagenladingen
80 F	alle 80 wagenladingen
1 J	1 x jaarlijks
100 ha	alle 100 hectaren
FETT	VET
▽	= Aantal smeernippels
(IV)	Zie aanhangsel "Smeermiddelen"
Liter	Liter
*	Varianten
	zie gebruiksaanwijzing van de fabrikant

### S Smörjschema

8 <sup>h</sup>	Varje 8:e driftstimme
20 <sup>h</sup>	Varje 20:e driftstimme
40 F	Varje 40:e lass
80 F	Varje 80:e lass
1 J	1 x årligen
100 ha	Varje 100:e ha
FETT	FETT
▽	= Antal smörjnippel
(IV)	Se avsnitt "Drivmedel"
Liter	liter
*	Utrustningsvariant
	Se tillverkarens anvisningar

### N Smøreplan

8 <sup>h</sup>	Hver 8. arbeidstime
20 <sup>h</sup>	Hver 20. arbeidstime
40 F	Hvert 40. lass
80 F	Hvert 80. lass
1 J	1 x årlig
100 ha	Totalt 100 Hektar
FETT	FETT
▽	= Antall smørenipler
(IV)	Se vedlegg "Betriebsstoffe"
Liter	Liter
*	Unntak
	Se instruksjon fra produsent

### I Schema di lubrificazione

8 <sup>h</sup>	ogni 8 ore di esercizio
20 <sup>h</sup>	ogni 20 ore di esercizio
40 F	ogni 40 viaggi
80 F	ogni 80 viaggi
1 J	volta all'anno
100 ha	ogni 100 ettari
FETT	GRASSO
▽	= Numero degli ingrassatori
(IV)	vedi capitolo "materiali di esercizio"
Liter	litri
*	variante
	vedi istruzioni del fabbricante

### E Esquema de lubricación

8 <sup>h</sup>	Cada 8 horas de servicio
20 <sup>h</sup>	Cada 20 horas de servicio
40 F	Cada 40 viajes
80 F	Cada 80 viajes
1 J	1 vez al año
100 ha	Cada 100 hectáreas
FETT	FETT
▽	= Número de boquillas de engrase
(IV)	Véase anexo "Lubrificantes"
Liter	Litros
*	Variante
	Véanse instrucciones del fabricante

### P Plano de lubrificação

8 <sup>h</sup>	Em cada 8 horas de serviço
20 <sup>h</sup>	Em cada 20 horas de serviço
40 F	Em cada 40 transportes
80 F	Em cada 80 transportes
1 J	1x por ano
100 ha	Em cada 100 hectares
FETT	Lubrificante
▽	= Número dos bocais de lubrificação
(IV)	Ver anexo "Lubrificantes"
Liter	Litro
*	Variante
	Ver instruções do fabricante

### CZ Mazací plán

8 <sup>h</sup>	každých 8 hodin
20 <sup>h</sup>	každých 20 hodin
40 F	každých 40 vozů
80 F	každých 80 vozů
1 J	1 x ročně
100 ha	po 100 ha
FETT	TUK
▽	= Počet mazacích hlaviček
(IV)	Viz kapitola "Mazací prostředky vydání"
Liter	litru
*	Varianta
	viz. p. řučka výrobce

### H Kenési terv

8 <sup>h</sup>	minden 8 üzemóra után
20 <sup>h</sup>	minden 20 üzemóra után
40 F	minden 40 menet után
80 F	minden 80 menet után
1 J	1-szer évente
100 ha	minden 100 Hektár után
FETT	ZSÍR
▽	= A zsírzógombok száma
(IV)	Nézd a "Kenőanyagok" c. fejezetet
Liter	Liter
*	Változat
	Nézd a gyártó utasításait!

### RUS Схема смазки

8 <sup>h</sup>	через каждые 8 часов работы
20 <sup>h</sup>	через каждые 20 часов работы
40 F	через каждые 40 подво
80 F	через каждые 80 подво
1 J	1 раз в год
100 ha	через каждые 100 га
FETT	СМАЗКА / OIL МАСЛО
▽	= количество смазочных ниппелей
(IV)	См. приложение «Эксплуатационные материалы»
Liter	литр (количество масла, жидкость,...)
*	Вариант
	Смотри руководство изготовителя

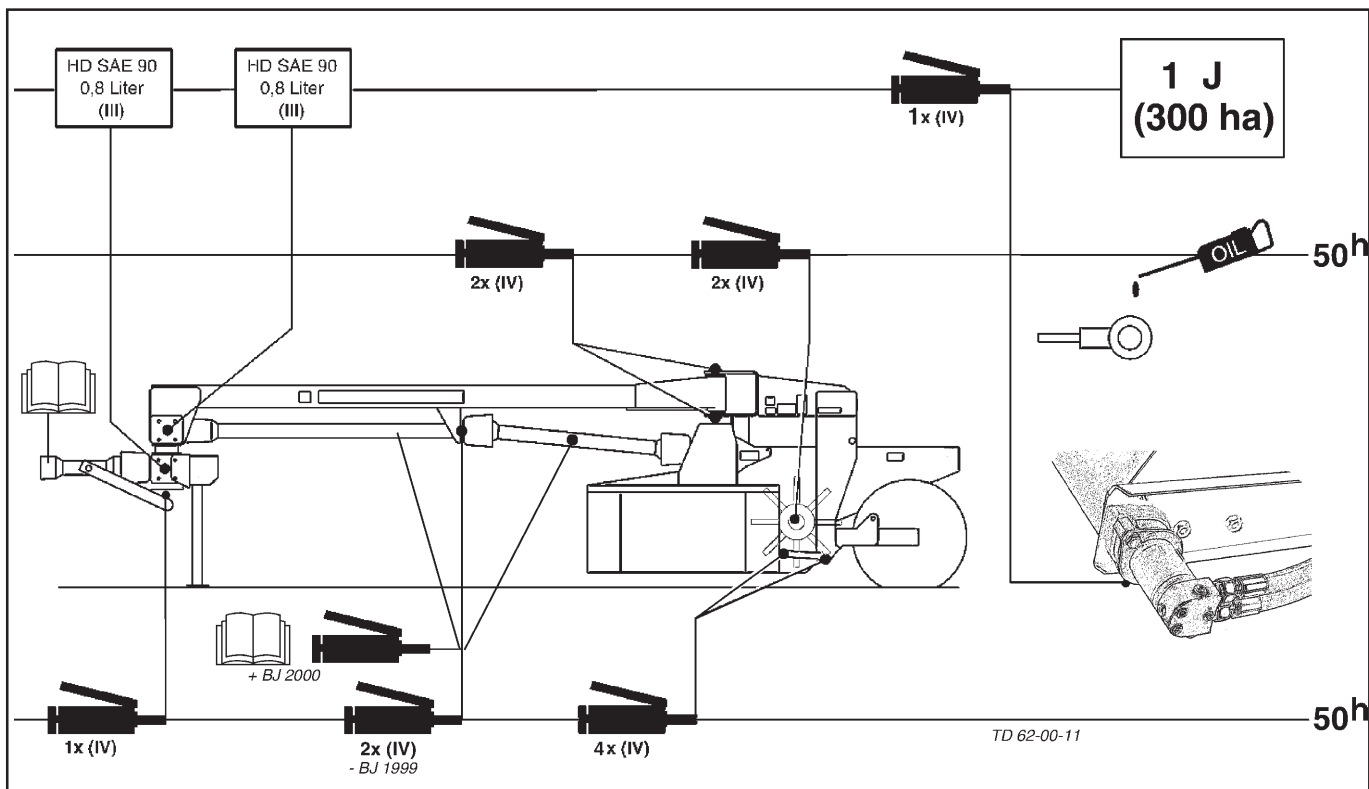
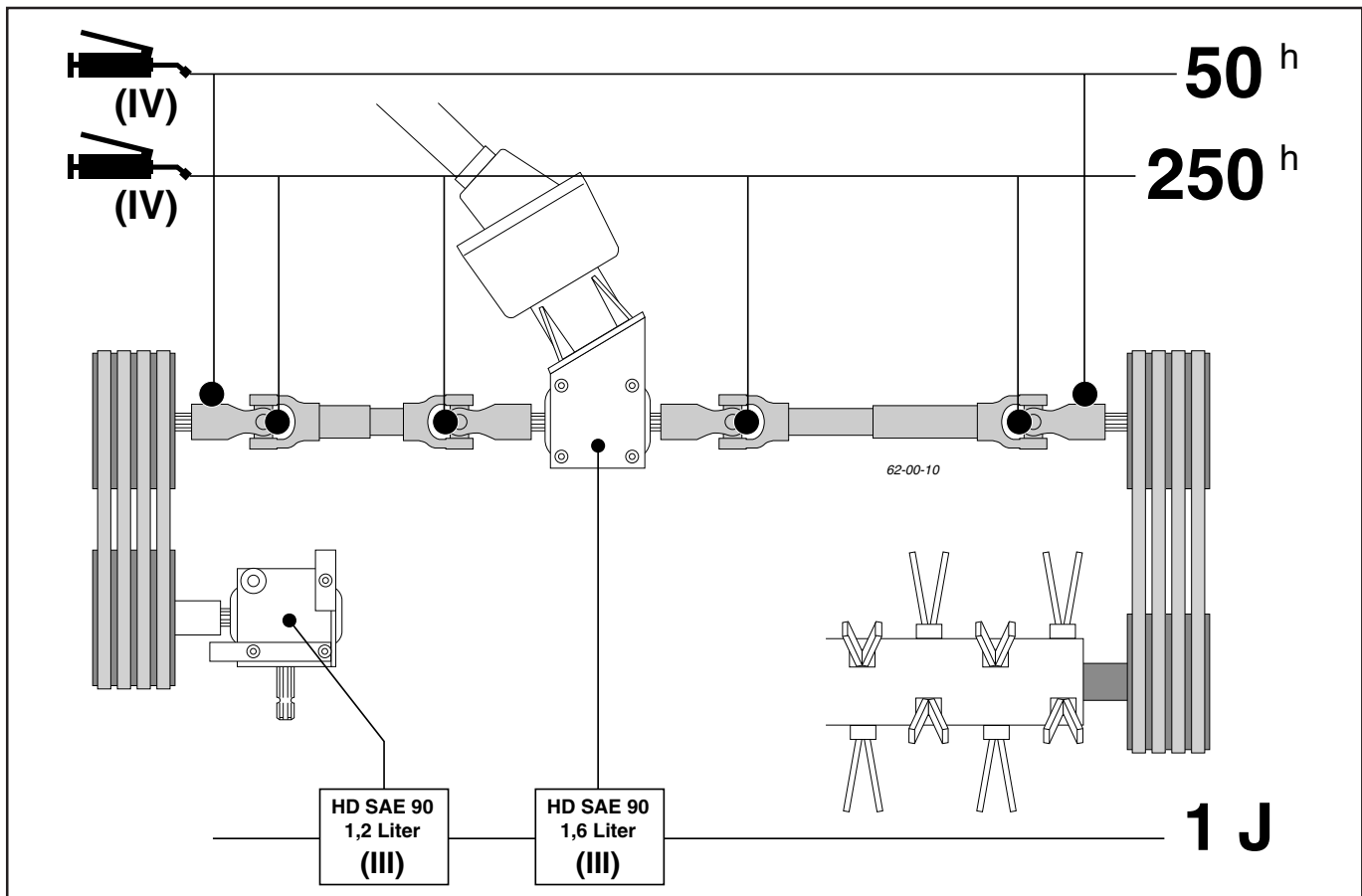

- D** **Maschinen mit Querförderband**  
Ölwechsel alle 2 Jahre (oder max. 4000 ha)
- F** **Machines avec tapis groupeur d'andains**  
Vidanger l'huile tous les 2 ans (ou max. 4000 ha)
- GB** **Machines with Cross conveyor**  
Change oil after 2 years (or max. 4000 ha)
- S** **Maskiner med tvärförbandsband**  
Oljebyte vart annat år (eller max. 400 ha)
- DK** **Maskiner med tværgående transportbånd**  
Udskift olien for hvert 2. år (eller maks. 4000 ha.)

- NL** **Machines met zijafvoerband**  
oliewissel om de twee jaren of na 4000 hectares
- E** **Máquinas con cinta transportadora transversal**  
Cambio de aceite cada 2 años (o máx. a las 4000 ha).
- PL** **Maszyny z bieżnią poprzeczną**  
Wymiana oleju co 2 lata (lub max. 400 ha)
- RUS** **Машины с поперечным ленточным конвейером**  
Замена масла через каждые 2 года (или макс. 400 га)

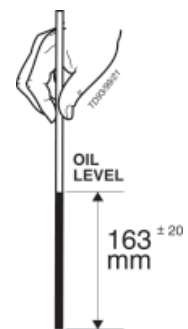
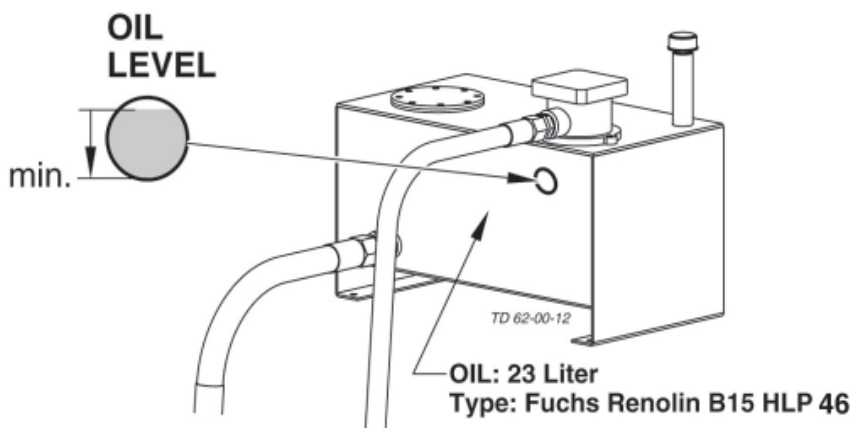

**(D) Zusammenbauanleitung**

- Zinken (2) immer paarweise auswechseln (Unwuchtgefahr)

**(F) Instructions de montage**

- Changer toujours les doigts (2) conditionneur deux par deux. (Risque de déséquilibre).

**(GB) Mounting instructions**

- Exchange the prongs (2) always in pairs (Unwuchtgefahr)

**(NL) Montage-aanwijzingen**

- tanden (2) altijd per paar verwisselen (onbalans)

**(E) Instrucciones de montaje**

- Sustituya las cuchillas (2) siempre en pares (peligro de desequilibrio).

**(RUS) Монтажное руководство**

- Зубы (2) всегда заменять попарно (опасность дисбаланса)

**(CZ) Montáž**

- prsty (2) montujte pouze do protilehlé polohy

**(PL) Instrukcja montażu**

- Ostrza (2) zawsze wymieniać parami

**(S) Monteringsvägledning**

- Byt alltid fingrarna (2) parvis (fara för jämnviktsstörningar)

Aufbereiter, Rotor **(D)**

Conditionneur, Rotor **(F)**

Conditioner, Rotor **(GB)**

Knikschudder, Rotor **(NL)**

Acondicionador, rotor **(E)**

Подготовительное устройство, ротор **(RUS)**

Kondicionér, Rotor **(CZ)**

Rozkładacz pokosu, rotor **(PL)**

Kross, rotor **(S)**

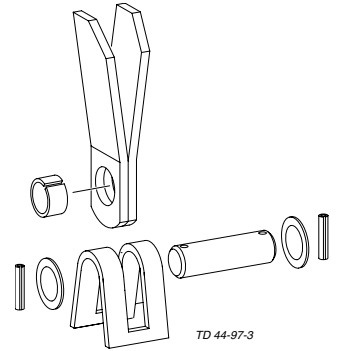
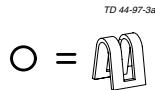
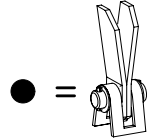
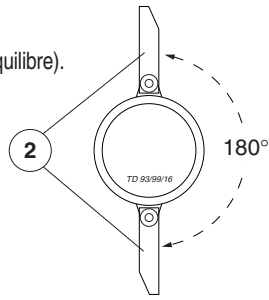

### CAT NOVA 260 T (Type PSM 352)

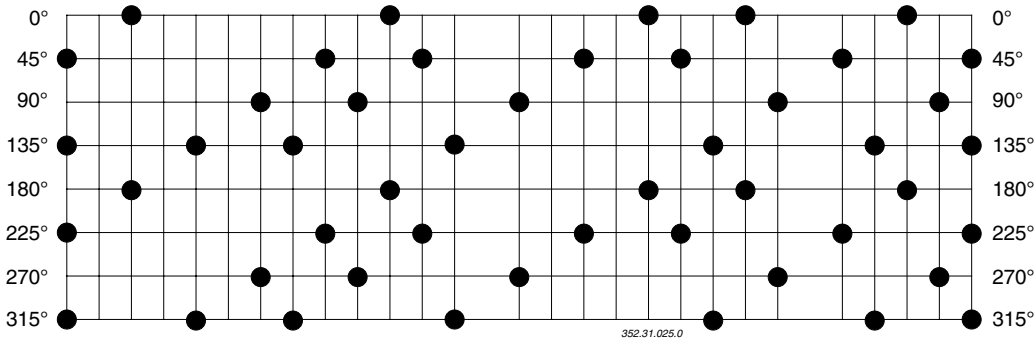

### CAT NOVA 310 T (Type PSM 353)

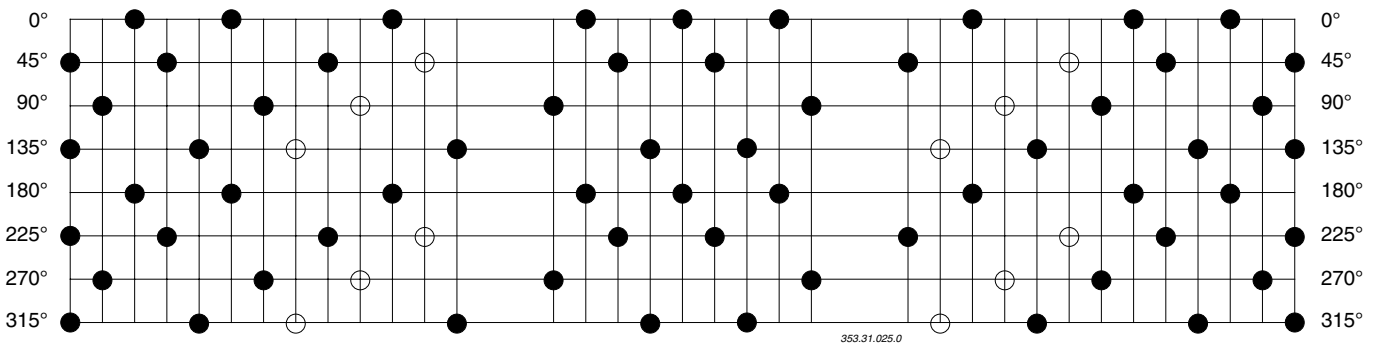

### CAT 310 T (Type PTM 337)

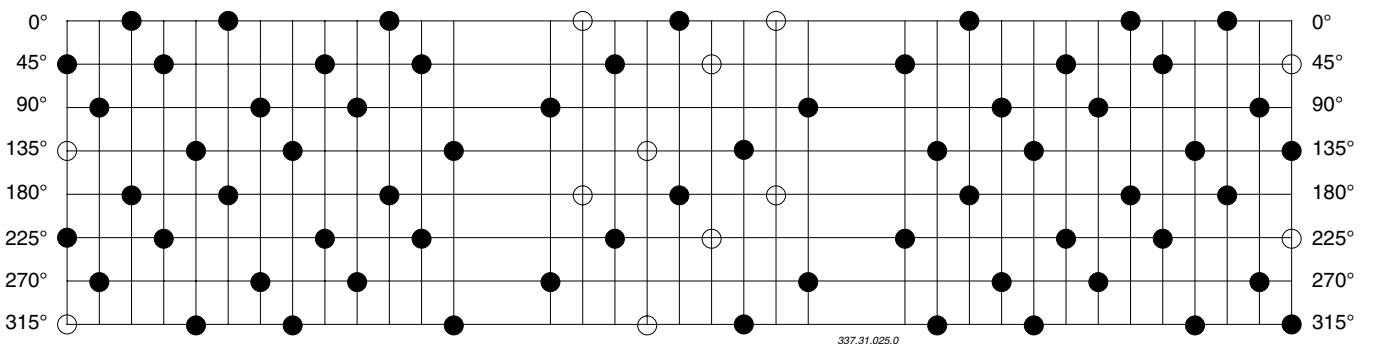

**Technical data**

**CAT 310 T**

**General**

Length (transport) .....	5180 mm
Width (transport) .....	3000 mm
Height (transport) .....	1910 mm
Length (work) .....	4870 mm
Ground clearance (transport) .....	380 mm
Height (work) .....	1450 mm
Weight .....	1950 kg
Tyres .....	10-80/12.3
Tyre pressure .....	2 bar
Attachment .....	Lower link Kat.II
Tractor capacity .....	from 59 kW (80 PS)
Driving motor speed .....	1000/540 r.p.m.
Continuous noise pressure level .....	91.1 dB (A)

**Cutter bar**

Cutting width .....	3050 mm
No. of mowing drums .....	4
Cutters per mowing drum .....	3
Cutting height .....	25-50 mm
Mowing drum r.p.m. ....	1886
Horizontal rocking .....	+5.5°
Longitudinal rocking .....	±3.5°
Vertical adjustment in the work position ....	±100 mm

**Processor**

System .....	Finger (V-form)
Width .....	2240 mm
No. of tines .....	62 double-finger
Rotor r.p.m. ....	860
Rotor diameter .....	600 mm
Swath width .....	900-1400 mm

**Necessary connections**

- 1 double-action hydraulic connection  
pressure min.: 140 bar  
pressure max.: 180 bar
- 1 single-action hydraulic connection  
pressure min.: 140 bar  
pressure max.: 180 bar
- 7-pole electric connection for lighting (12 Volt)
- 3-pole electric (12 Volt) connection (see supplement)

**Defined use of the mower**

The Rotary Mower "CAT 310 T" is intended solely for normal use in agricultural work:

- For the mowing of paddocks and field forage.  
Any other uses are regarded as not included in this definition.  
The manufacturer is not liable for any damage resulting from this. The user carries sole risk.
- Keeping to the maintenance and servicing conditions stipulated by the manufacturer is also included in the defined use.



Ihre/Your/Votre  
Masch.Nr. / Fgst.Ident.Nr.

**Position of Vehicle Identification Plate**

The factory number is imprinted on the accompanying Vehicle Identification Plate (as shown) and on the frame. Guarantee issues and further inquiries cannot be processed without the factory number being stated.

Please enter the number onto the front page of the operating manual immediately after taking delivery of the vehicle/implement.

---

## ***SUPPLEMENT***

The original cannot be copied

---

Things will run better with  
genuine Pöttinger parts

Original  
*inside*



- **Quality and precise fitting**
  - Operating safety.
- **Reliable operation**
- **Longer lasting**
  - Economy
- **Guaranteed availability** through your Pöttinger Sales Service.

The decision must be made, "original" or "imitation"? The decision is often governed by price and a "cheap buy" can sometimes be very expensive.

***Be sure you purchase the "Original" with the cloverleaf symbol!***

  
**PÖTTINGER**



**Recommendations for work safety**

All points referring to safety in this manual are indicated by this sign.

**1.) Defined use**

- a. See "Technical Data".
- b. The keeping of operating, service and maintenance requirements layed down by the manufacturer also come under the heading of "defined use".

**2.) Spare parts**

- a. The **original components and accessories** have been designed especially for these machines and appliances.
- b. We want to make it quite clear that components and accesories that have not been supplied by us have not been tested by us.
- c. The installation and/or use of such products can, therefore,

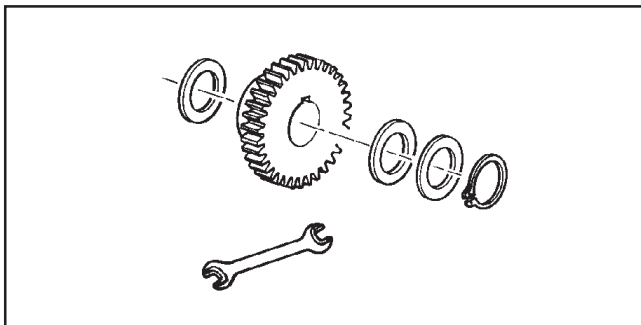

negatively change or influence the construction characteristics of the appliance. We are not liable for damages caused by the use of components and accessories that have not been supplied by us.

- d. Alterations and the use of auxiliary parts that are not permitted by the manufacturer render all liability invalid.

**3.) Protection devices**

All protection devices must remain on the machine and be maintained in proper condition. Punctual replacement of worn and damaged covers is essential.

**4.) Before starting work**

- a. Before commencing work, the operator must be aware of all operating devices and functions. The learning of these is too late after having already commenced operation!
- b. The vehicle is to be tested for traffic and operating safety before each operation.

**5.) Asbestos**

- Certain sub-supplied components of the vehicle may contain asbestos due to technical reasons. Observe the warning on spare parts.



**6.) Transport of persons prohibited**

- a. The transport of persons on the machine is not permitted.
- b. The machine may only be driven on public roads when in the position stipulated for road transport.

**7.) Driving ability with auxiliary equipment**

- a. The towing vehicle is to be sufficiently equipped with weights at the front or at the rear in order to guarantee the steering and braking capacity (a minimum of 20% of the vehicle's tare weight on the front axle).

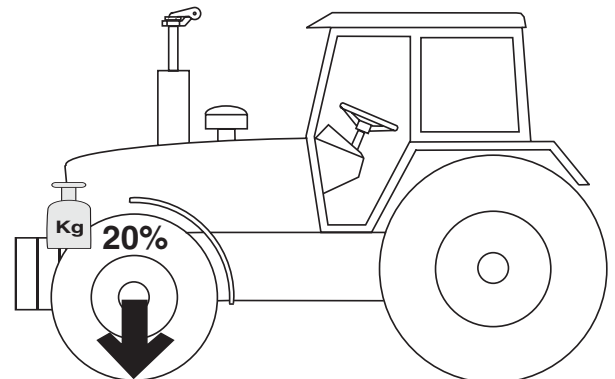

- b. The driving ability is influenced by ground conditions and by the auxiliary equipment. The driving must be adapted to the corresponding terrain and ground conditions.
- c. When driving through curves with a connected appliance, observe the radius and swinging mass of the appliance.
- d. When travelling in a curve with attached or semimounted implements, take into account the working range and swing mass of the implement!

**8.) General**

- a. Before attaching implement to three-point linkage, move system lever into a position whereby unintentional raising or lowering is ruled out!
- b. Danger of injury exists when coupling implement to tractor!
- c. Danger of injury through crushing and cutting exists in the three-point linkage area!
- d. Do not stand between tractor and implement when using three-point linkage external operation!
- e. Attach and detach drive shaft only when motor has stopped.
- f. When transporting with raised implement, secure operating lever against lowering!
- g. Before leaving tractor, lower attached implement to the ground and remove ignition key!
- h. Nobody is to stand between tractor and implement without tractor being secured against rolling using parking brake and/or wheel chocks!
- i. For all maintenance, service and modification work, turn driving motor off and remove universal drive.

**9.) Cleaning the machine**

Do not use high-pressure washers for the cleaning of bearing- and hydraulic parts.



**DRIVESHAFT**

**Important!** Only use the indicated or accompanying drive shaft, otherwise the right to claim under guarantee for any possible damage does not exist.

**Matching driveshaft to tractor**

To determine the actual length required, hold the two halves of the driveshaft side by side.

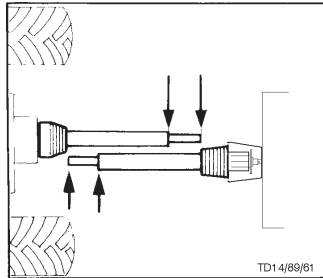

**Procedure for cutting to length**

- To determine length required, set implement in closest working position (L2) to tractor, hold driveshaft halves side by side and mark off.

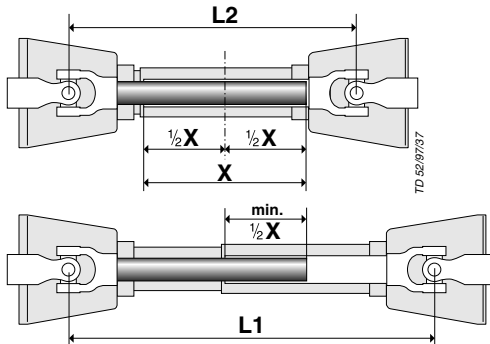

**Important!**

- Note the maximum operating length (L1)
  - Try to attain the greatest possible shaft overlap (min. 1/2 X)!
- Shorten inside and outside tube guard by the same amount.
- Fit torque limiter (2) of drive shaft to implement end of driveshaft!
- Always check that drive shaft locks are securely engaged before starting work.

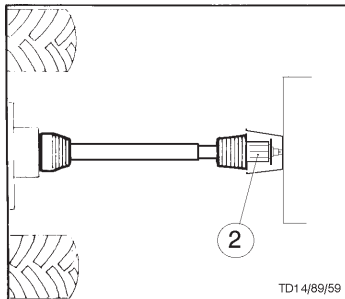

**Retaining chain**

- Use chain to prevent tube guard from rotating.
- Take care that chain does not impede driveshaft pivoting.

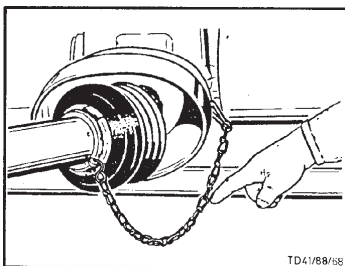

**Rules for working**

Never exceed the maximum p. t. o. speed when using the implement.

- When the p.t.o. is switched off, the implement hitched up may not stop at once. Do not go close to the implement until all motion has stopped; only then may work be done on it.
- When the implement is parked, either remove the driveshaft and store it, or secure it with a chain. (Do not use retaining chain (H) for this).

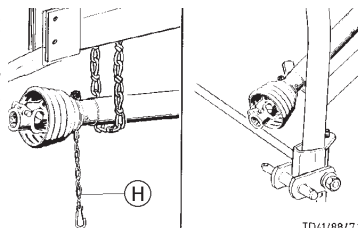

**1) How a cam type cut out safety clutch works:**

This overload clutch switches the torque transmitted to zero if overloaded. To revert to normal operation, stop the p.t.o. drive briefly.

The clutch reengages at a speed below 200 rpm.

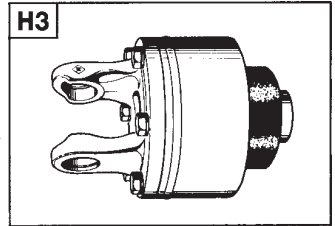

**IMPORTANT !**

The overload clutch on the driveshaft is not a "Full up" indicator. It is purely a torque limiter designed to protect the implement against damage.

Driving the right way will avoid triggering the clutch too often, and thus causing unnecessary wear on it and the implement.

**2) Wide-angle joint :**

Maximum angle of deflection when working/stationary : 70°

**3) Standard joint :**

Maximum angle of deflection when stationary: 90°

Maximum angle of deflection when working: 35°

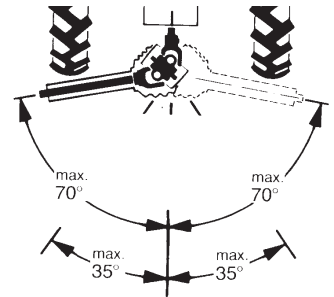

**Maintenance**

**Replace worn-out covers/guards at once.**

- Lubricate with a brand-name grease before starting work and every 8 hours worked.
- Before any extended period of non-use, clean and lubricate driveshaft.

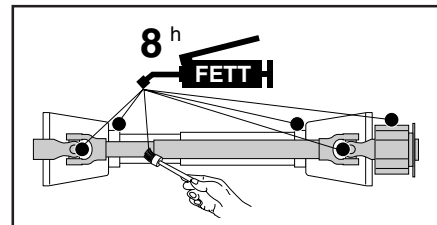

For winter working, grease the tube guards, to avoid them freezing together.

**• Important for driveshafts with friction clutch**

Prior to initial operation and after long periods out of use, check friction clutch for proper function.

- Measure dimension „L“ at compression spring of K90, K90/4 and K94/1 or at set screw of K92E and K92/4E.
  - Loosen screws to release the pressure on the friction disk.
  - Tighten set screws to dimension „L“.
- Clutch is ready for use.

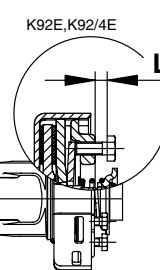
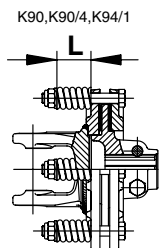

Leistung und Lebensdauer der Maschine sind von sorgfältiger Wartung und der Verwendung guter Betriebsstoffe abhängig. Unsere Betriebsstoffauslistung erleichtert die richtige Auswahl geeigneter Betriebsstoffe.

Im Schmierplan ist der jeweils einzusetzende Betriebsstoff durch die Betriebsstoffkennzahl (z.B. "III") symbolisiert. Anhand von "Betriebsstoffkennzahl" kann das geforderte Qualitätsmerkmal und das entsprechende Produkt der Mineralölfirmen festgestellt werden. Die Liste der Mineralölfirmen erhebt keinen Anspruch auf Vollständigkeit.

Getriebeöl gemäß Betriebsanleitung - jedoch mindestens 1 x jährlich wechseln.  
- Ölbletschraube herausnehmen, das Altöl auslaufen lassen und ordnungsgemäß entsorgen.

Vor Stilllegung (Winterperiode) Ölwechsel durchführen und alle Fettschmierstellen abschmieren. Blanke Metallteile außen (Gelenke, usw.) mit einem Produkt gemäß "IV" in der umseitigen Tabelle vor Rost schützen.

The performance and the lifetime of the farm machines are highly depending on a careful maintenance and application of correct lubricants. Our schedule enables an easy selection of selected products.

The applicable lubricants are symbolized (eg. "III"). According to this lubricant product code number the specification, quality and brand name of oil companies may easily be determined. The listing of the oil companies is not said to be complete.

Gear oils according to operating instructions - however at least once a year.

- Take out oil drain plug, let run out and duly dispose waste oil.

Before garaging (winter season) an oil change and greasing of all lubricating points has to be done. Unprotected, blanc metal parts outside (joints, etc.) have to be protected against corrosion with a group "IV" product as indicated on the reverse of this page.

Le bon fonctionnement et la longévité des machines dépendent d'un entretien soigneux et de l'utilisation de bons lubrifiants. Notre liste facilite le choix correct des lubrifiants.

Sur le tableau de graissage, on trouve un code (p.ex. "III") se référant à un lubrifiant donné. En consultant ce code on peut facilement déterminer la spécification demandée du lubrifiant. La liste des sociétés pétrolières ne prétend pas d'être complète.

Pour l'huile transmission consulter le cahier d'entretien - au moins une fois par an.

- Retirer le bouchon de vidange, laisser l'huile s'écouler et l'éliminer correctement.

Avant l'arrêt et hiver: vidanger et graisser. Métaux nus à l'extérieur protéger avec un produit type "IV" contre la rouille (consulter tableau au verso).

L'efficienza e la durata della macchina dipendono dall'accuratezza della sua manutenzione e dall'impiego dei lubrificanti adatti. Il nostro elenco dei lubrificanti Vi agevola nella scelta del lubrificante giusto.

Il lubrificante da utilizzarsi di volta in volta è simbolizzato nello schema di lubrificazione da un numero caratteristico (per es. "III"). In base al "numero caratteristico del lubrificante" si possono stabilire sia la caratteristica di qualità che il progetto corrispondente delle compagnie petrolifere. L'elenco delle compagnie petrolifere non ha pretese di completezza.

Motori a quattro tempi: bisogna effettuare il cambio dell'olio ogni 100 ore di funzionamento e quello dell'olio per cambi come stabilito nel manuale delle istruzioni per l'uso (tuttavia, almeno 1 volta all'anno).

- Togliere il tappo di scarico a vite dell'olio; far scolare l'olio e eliminare l'olio come previsto dalla legge anti-inquinamento ambientale.

Effettuare il cambio dell'olio ed ingrassare tutte le parti che richiedono una lubrificazione a grasso prima del fermo invernale della macchina. Proteggere dalla ruggine tutte le parti metalliche esterne scoperte con un prodotto a norma di "IV" della tabella riportata sul retro della pagina.

Prestaties en levensduur van de machines zijn afhankelijk van een zorgvuldig onderhoud en het gebruik van goede smeermiddelen.



Dit schema vergemakkelijkt de goede keuze van de juiste smeermiddelen.

Olíe in aandrijvingen volgens de gebruiksaanwijzing verwisselen - echter tenminste 1 x jaarlijks.

- Aftaplug er uit nemen, de olie aftappen en milieuvriendelijk verwerken.

Voor het buiten gebruik stellen (winteperiode) de olie-wisels uitvoeren en alle vetnippel smeerpunten doorsmeren. Blanke metaaldelen (koppelingen enz.) met een produkt uit groep "IV" van de navolgende tabel tegen corrosie beschermen.

Betriebsstoff-Kennzahl Lubricant indicator Code du lubrifiant Numero caratteristico del lubrificante Smeermiddelen code	I	(II)	(III)	HEFT (IV)	V	VI	VII
gefordert Qualitätsmerkmal required quality level niveau de performance demandé caratteristica richiesta di qualità verlangte kwaliteitskenmerken	HYDRAULIKÖL HLP DIN 51524 Teil 2  Siehe Anmerkungen * ** ***	Motoröl SAE 30 gemäß API CD/SF motor oil SAE 30 according to API CD/SF huile moteur SAE 30 niveau API CD/SF olio motore SAE 30 secondo specifiche API CD/SF	Getriebeöl SAE 90 bzw. SAE 85 W-140 gemäß API-GL 4 oder API-GL 5 gear oil, SAE 90 resp. SAE 85 W-140 according to API-GL 4 or API-GL 5 huile transmission SAE 90 ou SAE 85 W-140, niveau API-GL 4 ou API-GL 5 olio per cambi e differenziali SAE 90 o SAE 85W-140 secondo specifiche API-GL 4 o API-GL 5	LI-Fett (DIN 51 502, KP 2K)  lithium grease  graisse au lithium  grasso al litio	Getriebeöl SAE 90 (DIN 51 502: GOH)  transmission grease  graisse transmission  grasso fluido per riduttori e motoriduttori	Komplexfett (DIN 51 502: KP 1F)  complex grease  graisse complexe  grasso a base di saponi complessi	Getriebeöl SAE 90 bzw. 85 W-140 gemäß API-GL 5 gear oil SAE 90 resp. SAE 85 W-140 according to API-GL 5 huile transmission SA 90 ou SAE 85 W-140, niveau API GL 5 olio per cambi e differenziali SAE 90 o SAE 85 W-140 secondo specifiche API-GL 5

Firma Company Société Societá	I				V	VI	VII	ANMERKUNGEN
AGIP	OSO 32/46/68 ARNICA 22/46	MOTOROIL HD 30 SIGMA MULTI 15W-40 SUPER TRACTOR OIL UNIVERS. 15W-30	ROTRA HY 80W-90/85W-140 ROTRA MP 80W-90/85W-140	GR MU 2	GR SLL GR LFO		ROTRA MP 80W-90 ROTRA MP 85W-140	* Bij gebruik op trekkers met natte remmen moet de internationale specificatie J 20 A worden toegepast
ARAL	VITAM GF 32/46/68 VITAM HF 32/46	SUPER KOWAL 30 MULTI TURBORAL SUPER TRAKTORAL 15W-30	GETRIEBEÖL EP 90 GETRIEBEÖL HYP 85W-90	ARALUB HL 2	ARALUB FDP 00	ARALUB FK 2	GETRIEBEÖL HYP 90 GETRIEBEÖL HYP 90 EP MULTIHYP 85W-140 EP	** Hydrauliekolie HLP-(D) + HV
AVIA	AVILUB RL 32/46 AVILUB VG 32/46	MOTOROIL HD 30 MULTIGRADE HDC 15W-40 TRACTAVIA HF SUPER 10 W-30 TRACTAVIA HF SUPER 10 W-30	GETRIEBEÖL MZ 90 M MULTIHYP 85W-140	AVIA MEHRZWECKFETT AVIA ABSCHMIERFETT	AVIA GETRIEBEFLEISSFETT	AVIALUB SPEZIALFETT LD	GETRIEBEÖL HYP 90 EP MULTIHYP 85W-140 EP	
BAYWA	HYDRAULIKÖL HLP 32/46/68 SUPER 2000 CD-MC * HYDRA HYDR. FLUID * HYDRAULIKÖL MC 530 ** PLANTOHYD 40N ***	SUPER 2000 CD-MC SUPER 2000 CD HD SUPERIOR 20 W-30 HD SUPERIOR SAE 30	SUPER 8090 MC HYPOID 80W-90 HYPOID 85W-140	MULTI FETT 2 SPEZIALFETT FILM PLANTOGEL 2 N	GETRIEBEFLEISSFETT NLGI 0 RENOLIT DURAPLEX EP 00 PLANTOGEL 00N	RENOPLX EP 1	HYPOID 85W-140	*** Hydrauliekolie op plantenoliabasis HLP + HV is biologisch afbreekbaar, daarom milieuvriendelijk
BP	ENERGOL SHF 32/46/68	VISCO 2000 ENERGOL HD 30 VANELLUS M 30	GEAR OIL 90 EP HYPOGEAR 90 EP	ENERGEGREASE LS-EP 2	FLIESSFETT NO ENERGEGREASE HTO	OLEX PR 9142	HYPOGEAR 90 EP HYPOGEAR 85W-140 EP	
CASTROL	HYSPIN AWS 32/46/68 HYSPIN AWH 32/46	RX SUPER DIESEL 15W-40 POWERTRANS	EPX 80W-90 HYPOY C 80W-140	CASTROL GREASE LM	IMPERVIA MMO	CASTROL GREASE LMX	EPX 80W-90 HYPOY C 80W-140	
ELAN	HLP 32/46/68 HLP-M M32/M46	MOTORÖL 100 MS SAE 30 MOTORÖL 104 CM 15W-40 AUSTROTRAC 15W-30	GETRIEBEÖL MP 85W-90 GETRIEBEÖL B 65W-90 GETRIEBEÖL C 85W-140	LORENA 46 LITORA 27	RHENOX 34		GETRIEBEÖL B 85W-90 GETRIEBEÖL C 85W-140	
ELF	OLNA 32/46/68 HYDRELF 46/68	PERFORMANCE 2 B SAE 30 8000 TOURS 20W-30 TRACTORELF ST 15W-30	TRANSSELF TYP B 90 85W-140 TRANSSELF EP 90 85W-140	EPEXA 2 ROLEXA 2 MULTI 2	GA O EP POLY GO	MULTIMOTIVE 1	TRANSSELF TYP B 90 85W-140 TRANSSELF TYP BLS 80 W-90	
ESSO	NUTO H 32/46/68 NUTO HF 32/46/68	PLUS MOTORÖL 20W-30 UNIFARM 15W-30	GEARÖL GP 80W-90 GEARÖL GP 85W-140	MULTI PURPOSE GREASE H	FIBRAX EP 370	NEBULA EP 1 GP GREASE	GEAR OIL CX 80W-90 GEAR OIL GX 85W-140	* When working in conjunction with wet- brake tractors, the international specification J 20 A is necessary.
EVVA	ENAK HLP 32/46/68 ENAK MULTI 46/68	SUPER EWAROL HDB SAE 30 UNIVERSAL TRACTOR OIL SUPER	HYPOID GA 90 HYPOID GB 90	HOCHDRUCKFETT LT/SC 280	GETRIEBEFETT MO 370	EVVA CA 300	HYPOID GB 90	
FINA	HYDRAN 32/46/68	DELTA PLUS SAE 30 SUPER UNIVERSAL OIL	PONTONIC N 85W-90 PONTONIC MP 85W-90 85W-140 SUPER UNIVERSAL OIL	MARSON EP L 2	NATRAN 00	MARSON AX 2	PONTONIC MP 85W-140	** Hydraulic oil HLP-(D) + HV.
FUCHS	RENOLIN 1025 MC *** TITAN HYDRAMOT 1030 MC ** RENOGEAR HYDRA * PLANTOHYD 40N ***	TITAN HYDRAMOT 1030 MC TITAN UNIVERSAL HD	RENOGEAR SUPER 8090 MC RENOGEAR HYPOID 85W-140 RENOGEAR HYPOID 90	RENOLIT MP RENOLIT FILM 2 RENOLIT ADHESIV 2 PLANTOGEL 2 N	RENOSOD GFO 35 DURAPLEX EP 00 PLANTOGEL 00N	RENOPLX EP 1	RENOGEAR SUPER 8090 MC RENOGEAR HYPOID 85W-140 RENOGEAR HYPOID 90	*** Hydraulic oil with vegetable oil base HLP + HV is bio-degradable and is therefore especially safe for the environment.
GENOL	HYDRAULIKÖL HLP 32/46/68 HYDRAMOT 1030 MC * HYDRAULIKÖL 520 *** PLANTOHYD 40N ***	MULTI 2030 2000 TC HYDRAMOT 15W-30 HYDRAMOT 1030 MC	GETRIEBEÖL MP 90 HYPOID EP 90 HYPOID 85W-140	MEHRZWECKFETT SPEZIALFETT GLM PLANTOGEL 2 N	GETRIEBEFLEISSFETT PLANTOGEL 00N	RENOPLX EP 1	HYPOID EP 90 HYPOID 85W-140	
MOBIL	DTE 22/24/25 DTE 13/15	HD 20W-20 DELVAC 1230 SUPER UNIVERSAL 15W-30	MOBILUBE GX 90 MOBILUBE HD 90 MEHRZWECKGETRIEBEÖL SAE 90 HYPOID EP 90	MOBIL GREASE MP	MOBILUX EP 004	MOBILPLEX 47	MOBILUBE HD 90 MOBILUBE HD 85W-140	
RHG	RENOLIN B 10/15/20 RENOLIN B 32 HV/46HV1	EXTRA HD 30 SUPER 20 W-30	MEHRZWECKGETRIEBEÖL SAE 90 HYPOID EP 90	MEHRZWECKFETT RENOLIT MP DURAPLEX EP	RENOSOD GFO 35	RENOPLX EP 1	HYPOID EP 90	
SHELL	TELLUS S32/S 46/S68 TELLUS T 32/146	AGROMA 15W-30 ROTELLA X 30 RIMULUX 15W-40	SPIRAX 90 EP SPIRAX HD 90 SPIRAX HD 85/140	RETNAX A ALVANIA EP 2	SPEZ GETRIEBEFETT H SIMMUNA GREASE C	AEROSHELL GREASE 22 DOLIUM GREASE R	SPIRAX HD 90 SPIRAX HD 85W-140	
TOTAL	AZOLLA ZS 32, 46, 68 EQUIVUS ZS 32, 46, 68	RUBIA H 30 MULTI TAGRI TM 15W-20	TOTAL EP 85W-90 TOTAL EP B 85W-90	MULTIS EP 2	MULTIS EP 200	MULTIS HT 1	TOTAL EP B 85W-90	
VALVOLINE	ULTRAMAX HLP 32/46/68 SUPER TRAC FE 10W-30 ULTRAMAX HYP 32 10W-30 ULTRAMAX ULTRAPLANT 40 ***	SUPER HPO 30 TOP 15W-30 SUPER TRAC FE 10W-30 ALL FLEET PLUS 15W-40	HP GEAR OIL 90 oder 85W-140 TRANS GEAR OIL 80W-90	MULTILUBE EP 2 VAL-PLX EP 2 PLANTOGEL 2 N	RENOLIT LZB 000 DEGRALUB ZSA 000	DURAPLEX EP 1	HP GEAR OIL 90 oder 85W-140	
VEEDOL	ANDARIN 32/46/68	HD PLUS SAE 30	MULTIGRADE SAE 80/90 MULTIGEAR B 90 MULTIGEAR C SAE 85W-140	MULTIPURPOSE			MULTIGEAR B 90 MULTI C SAE 85W-140	
WINTERSHALL	WIOLAN HS (HG) 32/46/68 WIOLAN HVG 46 *** WIOLAN HF 32/46 *** HYDROFLUID *	MULTI-REKORD 15W-40 PRIMANOL REKORD 30	HYPOID-GETRIEBEÖL 80W-90, 85W-140 MEHRZWECKGETRIEBEÖL 80W-90	WIOLUB LFP 2	WIOLUB GFW	WIOLUB AFK 2	HYPOID-GETRIEBEÖL 80W-90, 85W-140	

## Preparation



- **Safety advice:** see Supplement A1, pts. 1- 3 and 8.
- **Only lift loads using lifting equipment with sufficient load capacity dimensions and stability.**

### Setting required driving motor speed

Possible are:

- 540 r.p.m.
- 1000 r.p.m.

- Check the necessary r.p.m.:

Driving motor stub (9)	Intermediate shaft (10)	Driving motor speed
1 revolution	1.3 revolutions	540 r.p.m.
1 revolution	0.75 revolutions	1000 r.p.m.

When only one revolution is possible on tractor and this does not agree with driving motor speed:

### Turn gearing round

- Disconnect intermediate shaft (1): see accompanying drive shaft instruction manual.

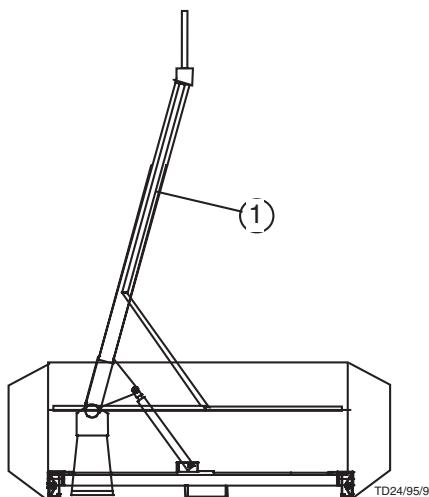

- On both sides:
  - Remove safety chain.
  - Dismount protection and slide back.
  - Unlock: push locking pin in and hold.
  - Remove drive shaft.

- Support drawbar (2).

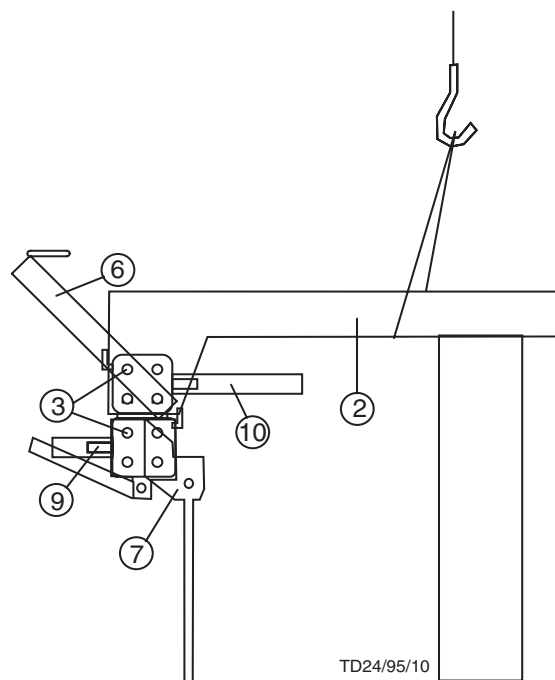

- Loosen the 16 fastening screws (3).

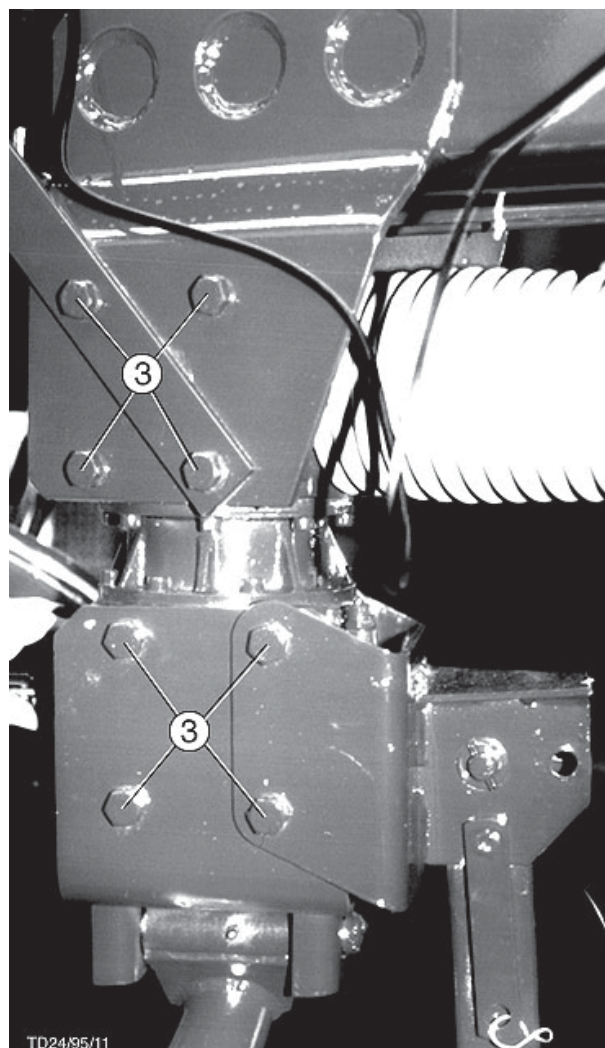

- Change oil filler connections (4) round:
- Screw out connections and screws opposite (5) and screw in reversed.

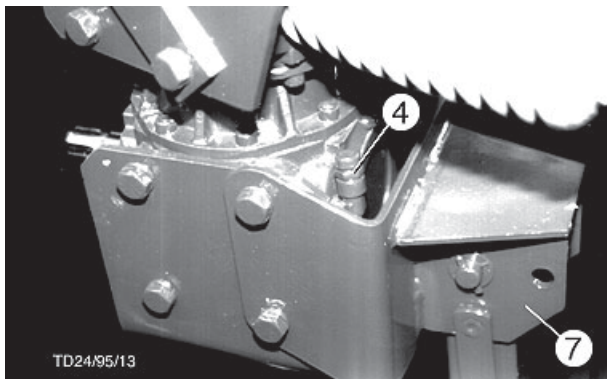
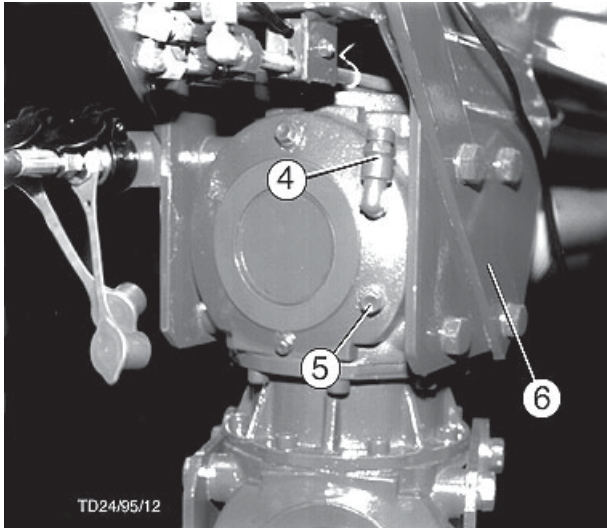

With turned-round gearing (11) the oil fill connections (4) appear in the same position as before.

- Turn gearing round

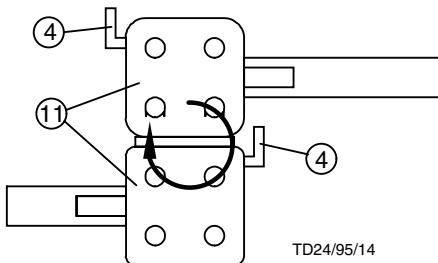

- Screw up the gearing with the drawbar (2), the cable routing (6) and the support stand holder (7).

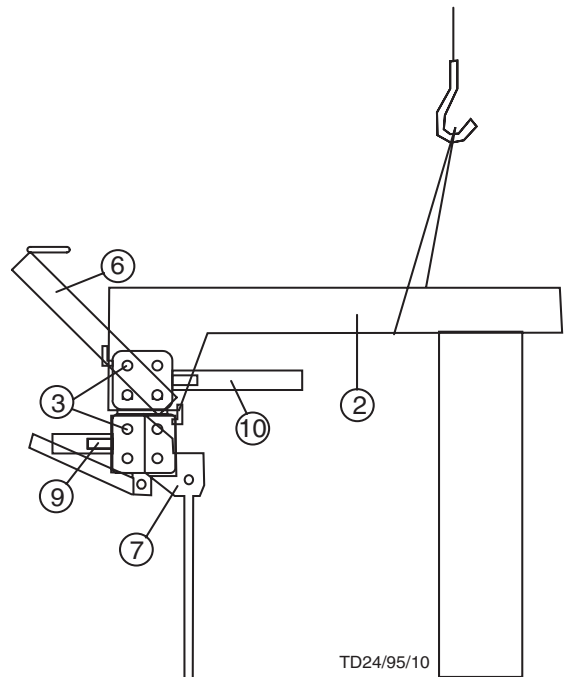

- Swing support stand (8) down and secure : Pos U

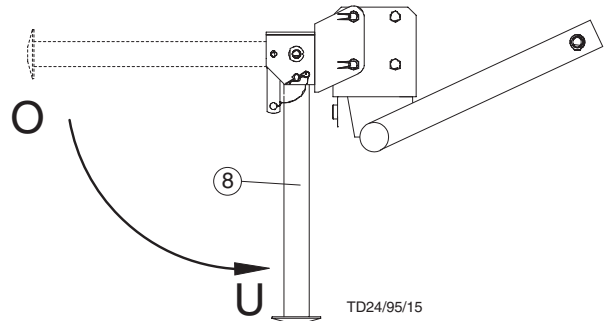

- Lower machine onto support stand.
- Attach intermediate shaft to driven side and secure so that safety device engages in slot:  
The locking pin must come out again completely when released.
- Attach intermediate shaft to gearing stub and secure.
- Slide protecting tube over the joint, fasten and secure against turning with the chain.

## Power supply

### Required fitting to tractor

- 3-pole power socket
  - Fix accompanying 3-pole power socket to the rear of the tractor
- Power supply through a relay (9)
- Relay is connected to the ignition switch (10).
- Conductor diameter at least 2,5 mm<sup>2</sup>
- Fuse 16A (11)



**This conversion is to be made only by a specialist.**

**Do not connect directly to ignition switch (danger of fire or damage to electrical unit).**

**Use only recommended-strength fuses as the use of stronger fuses will destroy the electrical unit!**

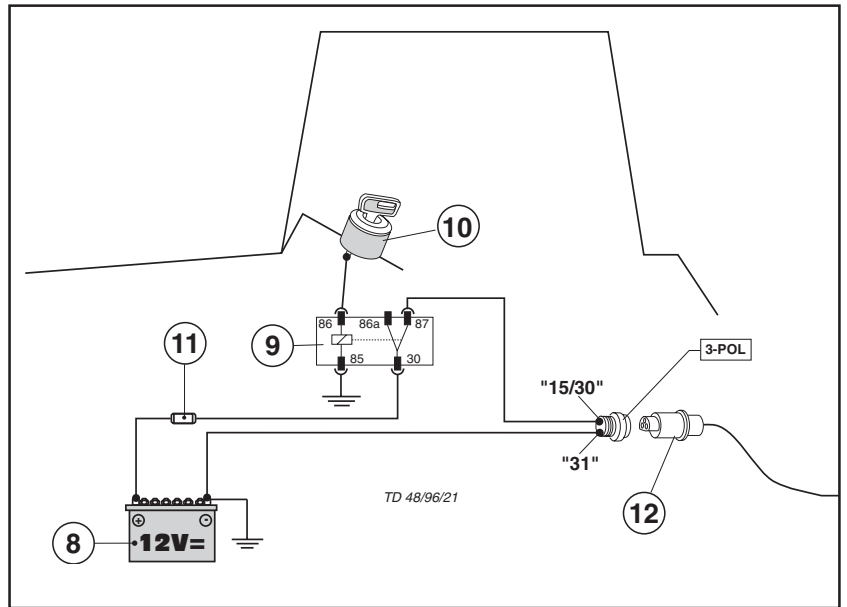

### Establishing the connection to tractor

- After completion of the work as shown, plug the 3-pole plugs into the tractor's power sockets.
- Check that lights are functioning.

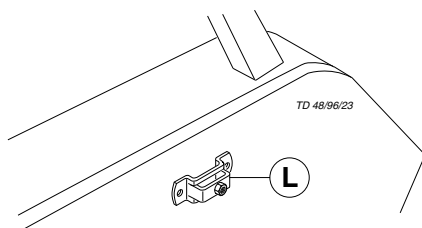
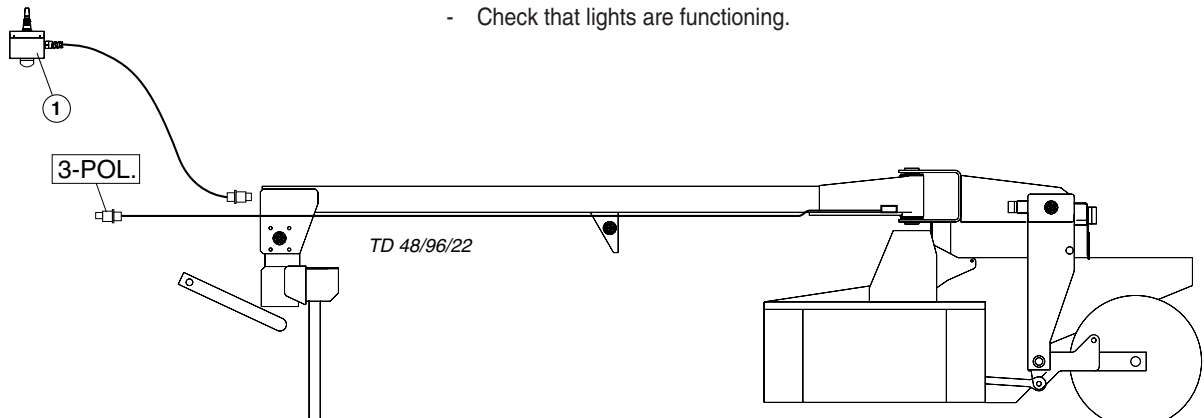

## Installation of control panel

- Install the accompanying splicing plate (L) into tractor cabin so that it is within the driver's sight and reach.
- Insert control panel (1) in splicing plate.

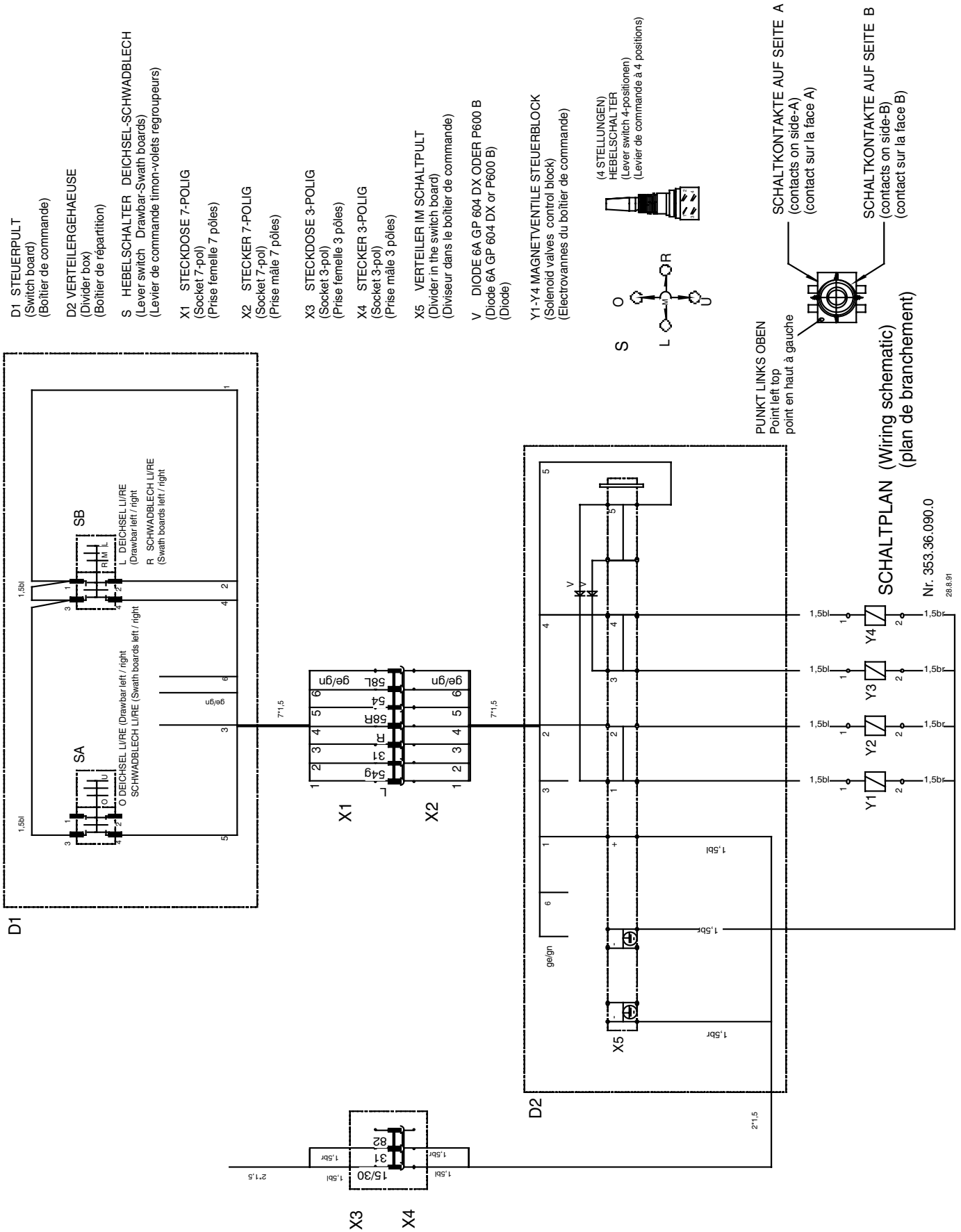

## Combination of tractor and mounted implement



The mounting of implements on the front or rear three point linkage shall not result in exceeding the maximum permissible weight, the permissible axle loads and the tyre load carrying capacities of the tractor. The front axle of the tractor must always be loaded with at least 20 % of the unladen weight of the tractor.

Make sure before buying an implement that these conditions are fulfilled by carrying out the following calculations or by weighing the tractor/implement combination.

### Determination of the total weight, the axle loads, the tyre load carrying capacity and the necessary minimum ballasting

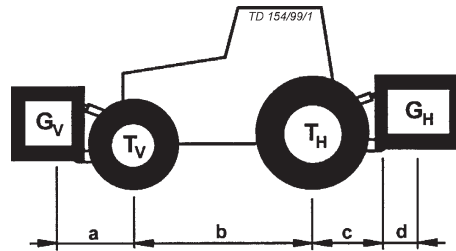

#### For the calculation you need the following data:

$T_L$ [kg]	unladen weight of tractor	①	$a$ [m]	distance from centre of gravity for combined front mounted implement/front ballast to front axle centre	② ③
$T_V$ [kg]	front axle load of unladen tractor	①			
$T_H$ [kg]	rear axle load of unladen tractor	①	$b$ [m]	Tractor wheelbase	① ③
$G_H$ [kg]	combined weight of rear mounted implement/rear ballast	②	$c$ [m]	distance from rear axle centre to centre of lower link balls	① ③
$G_V$ [kg]	combined weight of front mounted implement/front ballast	②	$d$ [m]	distance from centre of lower link balls to centre of gravity for combined rear mounted implement/rear ballast	②

- ① see instruction handbook of the tractor
- ② see price list and/or instruction handbook of the implement
- ③ to be measured

#### Consideration of rear mounted implement and front/rear combinations

##### 1. CALCULATION OF MINIMUM BALLASTING AT THE FRONT $G_{V \min}$

$$G_{V \min} = \frac{G_H \cdot (c + d) - T_V \cdot b + 0,2 \cdot T_L \cdot b}{a + b}$$

Record the calculated minimum ballasting which is needed at the front of the tractor into the table.

#### Front mounted implement

##### 2. CALCULATION OF THE MINIMUM $G_{H \min}$

Record the calculated minimum ballasting which is needed at the rear of the tractor into the table.

$$G_{H \min} = \frac{G_V \cdot a - T_H \cdot b + 0,45 \cdot T_L \cdot b}{b + c + d}$$

### 3. CALCULATION OF THE REAL FRONT AXLE LOAD $T_{V\text{tat}}$

(If with the front mounted implement ( $G_V$ ) the required minimum front ballasting ( $G_{V\text{min}}$ ) cannot be reached, the weight of the front mounted implement has to be increased to the weight of the minimum ballasting at the front!)

$$T_{V\text{tat}} = \frac{G_V \cdot (a + b) + T_V \cdot b - G_H \cdot (c + d)}{b}$$

Record the calculated real front axle load and the permissible front axle load of the tractor into the table.

### 4. CALCULATION OF THE REAL TOTAL WEIGHT $G_{\text{tat}}$

(If with the rear mounted implement ( $G_H$ ) the required minimum rear ballasting ( $G_{H\text{min}}$ ) cannot be reached, the weight of the rear mounted implements has to be increased to at least the weight of the minimum ballasting at the rear!)

$$G_{\text{tat}} = G_V + T_L + G_H$$

Record the calculated real and the permissible total weight given in the instruction handbook for the tractor into the table.

### 5. CALCULATION OF THE REAL REAR AXLE LOAD $T_{H\text{tat}}$

Record the calculated real and the permissible rear axle load given in the instruction handbook for the tractor into the table.

$$T_{H\text{tat}} = G_{\text{tat}} - T_{V\text{tat}}$$

### 6. TYRE LOAD CARRYING CAPACITY

Record double the value (two tyres) of the permissible load carrying capacity into the table (see for instance documentation provided by the tyre manufacturer).

#### Table

	Real value according to calculation		Permissible value according to instruction handbook		Double permissible tyre load carrying capacity (two tyres)
Minimum ballasting front/rear	/ kg		---		---
Total weight	kg	≤	kg		---
Front axle load	kg	≤	kg	≤	kg
Rear axle load	kg	≤	kg	≤	kg

**The minimum ballasting has to be attached to the tractor either in form of a mounted implement or ballasting weight!**

**The calculated values must be less or equal (<) the permissible values!**

## EC Certificate of Conformity

conforming to EEC Directions 89/392

We ALOIS PÖTTINGER Maschinenfabrik Gesellschaft m.b.H.

*(name of supplier)*

A-4710 Grieskirchen; Industriestraße 1

*(full address of company - where this concerns authorized agents within the Common Market, also state the company name and manufacturer)*

declare in sole responsibility, that the product

Trommelmäher CAT 310 T conditioner, Type PTM 337

*(make, model)*

to which this certificate applies, conforms to the basic safety and health requirements of EEC Directions 98/37/EG,

*(if applicable)*

and to the other relevant EEC Directions.

*(title and/or number and date of issue of the other EEC Directions)*

*(if applicable)*

To effect correct application of the safety and health requirements stated in the EEC Directions, the following standards and/or technical specifications were consulted:

EN 292-1 : 1991, EN 292-2 : 1991, EN 745

*(title and/or number and date of issue of standards and/or specifications)*

Grieskirchen, 01.03.1999

*(Place and date of issue)*



pa. Ing. W. Leposa  
Entwicklungsleitung

*(Name and job function of authorized person)*

**D** Im Zuge der technischen Weiterentwicklung arbeitet die PÖTTINGER Ges.m.b.H ständig an der Verbesserung ihrer Produkte.

Änderungen gegenüber den Abbildungen und Beschreibungen dieser Betriebsanleitung müssen wir uns darum vorbehalten, ein Anspruch auf Änderungen an bereits ausgelieferten Maschinen kann daraus nicht abgeleitet werden.

Technische Angaben, Maße und Gewichte sind unverbindlich. Irrtümer vorbehalten.

Nachdruck oder Übersetzung, auch auszugsweise, nur mit schriftlicher Genehmigung der

ALOIS PÖTTINGER

Maschinenfabrik Gesellschaft m.b.H.

A-4710 Grieskirchen.

Alle Rechte nach dem Gesetz des Urheberrecht vorbehalten.

**NL** De PÖTTINGER Ges.m.b.H werkt permanent aan de verbetering van hun producten in het kader van hun technische ontwikkelingen. Daarom moeten wij ons veranderingen van de afbeeldingen en beschrijvingen van deze gebruiksaanwijzing voorbehouden, zonder dat daaruit een aanspraak op veranderingen van reeds geleverde machines kan worden afgeleid.

Technische gegevens, maten en gewichten zijn niet bindend. Vergissingen voorbehouden.

Nadruk of vertaling, ook gedeeltelijk, slechts met schriftelijke toestemming van de

ALOIS PÖTTINGER

Maschinenfabrik Gesellschaft m.b.H.

A-4710 Grieskirchen.

Alle rechten naar de wet over het auteursrecht voorbehouden.

**E** La empresa PÖTTINGER Ges.m.b.H se esfuerza continuamente en la mejora constante de sus productos, adaptándolos a la evolución técnica. Por ello nos vamos obligados a reservarnos todos los derechos de cualquier modificación de los productos con relación a las ilustraciones y a los textos del presente manual, sin que por ello pueda ser deducido derecho alguno a la modificación de máquinas ya suministradas.

Los datos técnicos, las medidas y los pesos se entienden sin compromiso alguno.

La reproducción o la traducción del presente manual de instrucciones, aunque sea tan solo parcial, requiere de la autorización por escrito de

ALOIS PÖTTINGER

Maschinenfabrik Gesellschaft m.b.H.

A-4710 Grieskirchen.

Todos los derechos están protegidos por la ley de la propiedad industrial.

**CZ** V důsledku technického vývoje pracuje firma PÖTTINGER Ges.m.b.H neustále na zlepšení svých výrobků.

Změny v návodu k používání si výrobce vyhrazuje. Požadavky na změnu návodu k používání na práve dodané stroje nemohou být vyvozovány.

Technické údaje, rozměry a hmotnosti jsou nezávazné.

Dotisk nebo nový překlad je možný pouze za písemného souhlasu firmy

ALOIS PÖTTINGER

Maschinenfabrik Gesellschaft m.b.H.

A-4710 Grieskirchen

Všechna práva podléhají autorskému právu.

**F** La société PÖTTINGER Ges.m.b.H améliore constamment ses produits grâce au progrès technique. C'est pourquoi nous nous réservons le droit de modifier descriptions et illustrations de cette notice d'utilisation, sans qu'on en puisse faire découler un droit à modifications sur des machines déjà livrées.

Caractéristiques techniques, dimensions et poids sont sans engagement. Des erreurs sont possibles.

Copie ou traduction, même d'extraits, seulement avec la permission écrite de

ALOIS PÖTTINGER

Maschinenfabrik Gesellschaft m.b.H.

A-4710 Grieskirchen.

Tous droits réservés selon la réglementation des droits d'auteurs.

**S** Beroende på den tekniska utvecklingen arbetar PÖTTINGER Ges.m.b.H. på att förbättra sina produkter.

Vi måste därför förbehålla oss förändringar gentemot avbildningarna och beskrivningarna i denna bruksanvisning. Däremot består det inget anspråk på förändringar av produkter beroende av denna bruksanvisning.

Tekniska uppgifter, mått och vikter är oförbindliga. Fel förbehållna.

Ett eftertryck och översättningar, även utdrag, får endast genomföras med skriftlig tillåtelse av

ALOIS PÖTTINGER

Maschinenfabrik Gesellschaft m.b.H.

A - 4710 Grieskirchen

Alla rättigheter enligt lagen om upphovsmannarätten förbehålls.

**I** La PÖTTINGER Ges.m.b.H è costantemente al lavoro per migliorare i suoi prodotti mantenendoli aggiornati rispetto allo sviluppo della tecnica.

Per questo motivo siamo costretti a riservarci la facoltà di apportare eventuali modifiche alle illustrazioni e alle descrizioni di queste istruzioni per l'uso. Allo stesso tempo ciò non comporta il diritto di fare apportare modifiche a macchine già fornite.

I dati tecnici, le misure e i pesi non sono impegnativi. Non rispondiamo di eventuali errori. Ristampa o traduzione, anche solo parziale, solo dietro consenso scritto della

ALOIS PÖTTINGER

Maschinenfabrik Gesellschaft m.b.H.

A-4710 Grieskirchen.

Ci riserviamo tutti i diritti previsti dalla legge sul diritto d'autore.

**HU** A műszaki termékfejlesztés folyamataiban a Pöttinger Ges.m.b.H. folyamatosan dolgozik termékei minőségének javításán.

Ezen kezelési utasítás ábráinak és leírásainak változtatási jogát fenntartjuk, emiatt nem lehet követeléssel fellépni egy már kiszállított gép megváltoztatásával kapcsolatban.

A műszaki adatok, méretek, tömegek, kötelezettség nélküliek. A tévedések joga fenntartva.

Utánnyomás vagy fordítás, akárcsak kivonatosan is, csak az

ALOIS PÖTTINGER

Maschinenfabrik Gesellschaft m.b.H.

A-4710 Grieskirchen írásos engedélyével történhet.

A szerzői jogi törvény értelmében minden jog fenntartva.

**GB** Following the policy of the PÖTTINGER Ges.m.b.H to improve their products as technical developments continue, PÖTTINGER reserve the right to make alterations which must not necessarily correspond to text and illustrations contained in this publication, and without incurring obligation to alter any machines previously delivered.

Technical data, dimensions and weights are given as an indication only. Responsibility for errors or omissions not accepted.

Reproduction or translation of this publication, in whole or part, is not permitted without the written consent of the ALOIS PÖTTINGER

Maschinenfabrik Gesellschaft m.b.H.

A-4710 Grieskirchen.

All rights under the provision of the Copyright Act are reserved.

**PL** W sensie dalszego rozwoju technicznego Poettinger nieustannie pracuje nad ulepszeniem swoich produktów. W związku z powyższym zastrzegamy sobie prawo do zmian w schematach i opisach znajdujących się w niniejszej instrukcji obsługi.

Nie wyklucza się prawa do zmian również w przypadku już dostarczonych maszyn.

Dane techniczne, wymiary i ciężary nie są wielkościami ostatecznymi. Dopuszcza się możliwość pojawienia się błędów.

Powielanie bądź tłumaczenia, również wrywkowe, wyłącznie za pisemną zgodą

ALOIS PÖTTINGER

Maschinenfabrik Gesellschaft m.b.H.

A-4710 Grieskirchen

Wszelkie prawa włącznie z prawami autorskimi zastrzeżone.

**RUS** В ходе технического развития фирма «ПЁТТИНГЕР Гез.м.б.Х.» постоянно занимается усовершенствованием своей продукции.

В связи с этим мы сохраняем за собой право вносить изменения в рисунки и описания этой инструкции по эксплуатации, однако, требование вносить такие изменения в уже поставленные машины предъявлению не подлежит.

Технические данные, указание размеров и массы даются без обязательств. Ошибки не исключены.

Перепечатка или перевод, в том числе отрывками, разрешается только с письменного согласия фирмы

«АЛОИС ПЁТТИНГЕР

Машиненфабрик Гезельшафт м.б.Х.»

A-4710 Грискирхен.

С сохранением всех прав в соответствии с авторским правом.

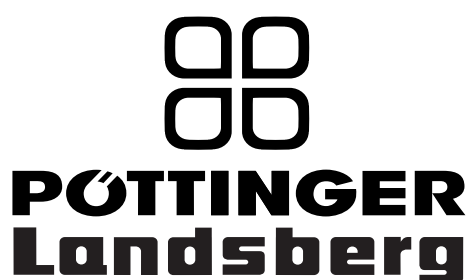

**ALOIS PÖTTINGER**

**Maschinenfabrik Gesellschaft m.b.H**

A-4710 Grieskirchen

Telefon: 0043 (0) 72 48 600-0

Telefax: 0043 (0) 72 48 600-511

e-Mail: landtechnik@poettinger.co.at

Internet: <http://www.poettinger.co.at>

**GEBR. PÖTTINGER GMBH**

**Stützpunkt Nord**

Wentruper Mark 10

D-48 268 Greven

Telefon: (0 25 71) 93 45 - 0

Ersatzteildienst: (0 25 71) 93 45 - 11

Kundendienst: (0 25 71) 93 45 - 12

Telefax: (0 25 71) 93 45 - 14

**PÖTTINGER France**

129 b, la Chapelle

F-68650 Le Bonhomme

Tél.: 03.89.47.28.30

Fax: 03.89.47.28.39

**GEBR. PÖTTINGER GMBH**

**Servicezentrum**

Spöttinger-Straße 24

Postfach 1561

D-86 899 LANDSBERG / LECH

Telefon:

Ersatzteildienst: 0 81 91 / 92 99 - 166 od. 169

Kundendienst: 0 81 91 / 92 99 - 130 od. 231

Telefax: 0 81 91 / 59 656