



**RP 12/12 S**  
**15 S**

OPERATING MANUAL

# C O N T E N T S

Instructions for prevention of accidents	1	Good driving practice	15
Technical Data	2	Locking tailgate	16
Preparing for operation	3	Bale density	16
Attaching the baler	3	Wrapping the bale	16
Fitting universal drive shaft	3	Wrapping unit - Hand tripping	17
Coupling of hydraulic hoses	4	for twine wrapping	17
Electrical connections	5	Setting end wrappings	18
Connecting signal box	5	Bale ejection	18
Twine wrapping	6	Overloading safety	19
Net wrapping	8	Servicing the baler	19
Field operation	12	Tightening bolts	20
Before road transport	12	Checking road wheels	20
Setting the bale counter	12	Chain lubrication	20
Pre-set bale density	12	Guide bar lubrication	20
Windrowing	12	Changing gear box oil	20
Pick-up guide wheel	13	Chain tension	21
Setting windguard	13	Safety arrangements	21
Pick-up cover shield	13	Out of season storage	22
Wide pick-up	13	Optional and additional equipment	23
Feed guide plate	14	Operational faults - Quick remedy	24
Setting pick-up height	15	Hints for driving on public roads	27
PTO speed	15	Wiring diagrams	28 - 30
Negotiating bends	15		

## Safety Instructions

Read the operating manual and follow the safety instructions!

The adjoining attention sign indicates important safety instructions and potential accident spots. Pass on the safety instructions to your operating personnel. The roll baler also has warning signs which give instructions for operation without danger. Pay attention to these for your own safety's sake.



The Machine Number of your baler is stamped into the data plate seen alongside on the top of the frame (see arrow). Warranty claims and enquiries cannot be dealt with without this number. Please make note of this number here immediately after delivery:

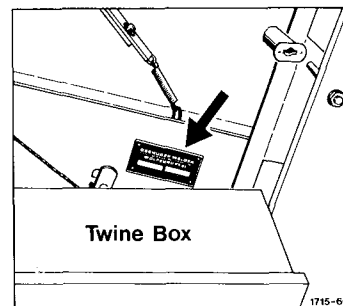

Reproduction prohibited - all rights reserved. Design and construction subject to alterations. Technical data are not binding.

Copyright 1991 by Gebrüder Welger GmbH & Co. Kommanditgesellschaft, Wolfenbüttel

Operating Manual No. 1713/1716.AE.00.03

FW. 03.91. 500 000

G E B R Ü D E R W E L G E R GmbH & Co. Kommanditgesellschaft

Gebrüder-Welger-Straße

Postfach 1965

3340 Wolfenbüttel

Telefon: (05331) 404-0

Telefax: (05331) 404-209

Teletex: (17) 5331 831

Telex: 95 639



## GENERAL SAFETY INSTRUCTION



Never carry out adjustments and repairs or maintenance and care operations on the machine while it is running.

Always first stop the p.t.o. shaft and pull the universal shaft off the p.t.o. shaft before work is carried out on moving parts of the machine.

When driving on public roads, the universal shaft must always be fitted on the tractor p.t.o. shaft.

Never try to pull hay or straw out of the pick-up unit or the feed opening while the machine is running. Always stop the p.t.o. shaft first.

While work is in progress, only the driver should be on the tractor. Passengers are not allowed on the baler. Do not climb on the drawbar or other parts of the baler when the latter is in operation. Also keep your distance from the pick-up unit and the belts.

All protective guards must be mounted on the baler and in sound condition. Before opening the guards etc. stop the p.t.o. shaft and the tractor engine and wait until the machine has stopped. Adjustments to the drawbar must only be carried out by a competent work shop.

When opening and closing the tailgate, no persons must be present within the opening range. In addition, persons are not allowed to be present within the area of the opened and unsecured tailgate.

Before entering the bale chamber, engage the tailgate support in the safety position.

Before starting installation or assembly work on the hydraulic system, release the oil pressure.

Close the tailgate before stopping the machine.

Pull the fixing chain of the universal shaft through the universal joint, to prevent the front part of the universal shaft from slipping out. Chock the road wheels of the baler with chocks when the baler is parked on sloping ground. Always carry chocks with you on the baler.

### Permissible use of the baler

The roll baler has been built exclusively for ordinary use in agricultural work (permissible use).

Any other use is regarded as not permissible. The manufacturer does not accept responsibility for damage arising from impermissible use; any risk is borne entirely by the user.

Permissible use also includes the observation of the operating-servicing and maintenance condition specified by the manufacturer. The attachment of implements is not permitted, except at the points provided for this by the works.

The roll baler must only be used, serviced and maintained by persons who are familiar with this work and who have been informed about all possible dangers.

The relevant accident prevention regulations as well as all other applicable regulations concerning safety, health hazards and road traffic must be observed.

Alterations carried out by the user, and the installation of unapproved parts and attachments on the machine exclude liability on the part of the manufacturer for any damage caused as a result.

TECHNICAL DATA

	RP 12 / RP 12 S	RP 15 S
Bale chamber size	1,20 m in diameter 1,20 m in width	1,55 m in diameter 1,20 m in width
Bale weight: straw	120 - 160 kg	200 - 300 kg
hay	160 - 250 kg	300 - 500 kg
wilted silage		
according to moisture content	450 - 600 kg	700 - 1000 kg
Bale density	Variable over wide range, outer layers more firmly compacted than inner	Variable over wide range, outer layers more firmly compacted than inner
Wrapping material		
a) Sisal twine runnage	200 or 330 m/kg	200 or 330 m/kg
b) Plastic twine runnage	400 - 700 m/kg	400 - 700 m/kg
c) Net	High quality net for rollbalers, at least 2 wrappings	High quality net for balers, at least 2 wrappings
d) Plastic foil (thickness)	80 µ, at least 4 wrappings	80 µ, at least 4 wrappings
Wrapping unit	Fully automatic or hand-tripped Twine, net or plastic foil	Fully automatic or hand-tripped Twine, net or plastic foil
Overall pick-up width	1,50 m	1,50 m
Pick-up lifting device	hydraulic	hydraulic
Tyres		
standard	10,0/75-15.3 Impl.6 PR	10,0/75-15.3 Impl.6PR
extra	11,5/80-15.3 Impl.6 PR	11,5/80-15.3 Impl.6PR
Hydraulic device	2 single acting cylinders for tailgate	2 single acting cylinders for tailgate
Required tractor power	1 single acting cylinder for pick-up Depending on bale density from 37 kW (50 hp)	1 single acting cylinder for pick-up Depending on bale density from 44 kW (60 hp)
PTO speed	540 rpm	540 rpm
Tractor hydraulic connection	1 or 2 single acting control valves with NW 10 push-in coupling	1 or 2 single acting control valves with NW 10 push-in coupl.
Drawbar	Adjustable in height from 40 - 90 cm	Adjustable in height from 40 - 90 cm
Baler capacity	30 - 40 bales/h with twine wrapping	20 - 30 bales/h with twine wrapping
Dimensions of roll baler:		
length	RP 12            RP 12 S	3,85 m
width	3,25 m           3,50 m	2,14 m
height	2,12 m           2,14 m	2,44 m
Weight of baler approx.	2,03 m           2,03 m	
	RP 12            RP 12 S	
	1690 kg          1740 kg	1940 kg

## PREPARING FOR OPERATION

### Attaching the Baler

The rollbaler should be connected to the tractor so that the twine box is about parallel to the ground. To do this, adjust the baler drawbar to the required height. This adjustment may only be made by an expert mechanic. Set baler in position with support wheel or jack to have the twine box parallel to the ground. Slacken lock nuts, remove protecting caps from the plastic holes on each side of the turnbuckle and adjust them equally to the required height using the lever supplied with the tools.



Turnbuckle only be turned to a certain extent, so that thread can still be seen on both sides in the check holes. Then tighten up lock nuts on both sides and replace protecting caps on check holes. If pick-up ground clearance is not sufficient because of unfavorable attaching conditions and standard tyres. Then use the extension blocks which can be delivered as optional equipment to remedy this.

After attaching the baler, turn support wheel or jack upwards until sufficient ground clearance is reached, then swing the support wheel up to engage in the right position.

### Fitting universal Drive Shaft

Clean PTO splines on tractor and baler. Push in sliding pins and fit universal drive shaft, sliding pins must be heard to engage properly. The wide angle joint must be on the tractor side. Check tube length. Free telescoping length must not be less than 200 mm when driving straight ahead. Cut equal amounts from both profile tubes and guard tubes if necessary. Make sure there is enough tube overlap. Secure guard tube with chain to prevent turning.

**IMPORTANT:** Make sure when turning sharp bends that the wide angle joint of drive shaft (tractor side) does not have an angle greater than that allowed by the PTO shaft manufacturer. Pay attention to the hints given in the PTO operating manual and any transfers about the protection of the PTO shaft.

#### Coupling of Hydraulic Hoses

The rollbaler has two hydraulic hoses with quick release couplings. One connection is for opening and closing the tailgate, the other connection with the lock valve is for lifting and lowering the pick-up. With the lock valve on the hose, the pick-up is hydraulically locked in transport position (see page 12 before road transport). The tractor should be fitted with two single acting valves with quick release (female) couplings NW 10.

If only one single acting valve is available on the tractor, the tailgate and the pick-up can still be operated hydraulically by this one valve. In this case the hose without the locking valve is connected. The required function, either tailgate or pick-up, is then controlled by the change over valve mounted on the baler. Observe respective transfer on baler.

A hydraulic remote control is available as optional equipment, with which the required function can be operated from the tractor. In standard position the control lever of the change-over valve points to the right. If both hoses are connected, both pick-up and tailgate can be operated from the tractor. If only one hose is connected, only the tailgate can be opened and closed. To operate the pick-up with only one hose, turn the control lever to the left. Lower pick-up before baling and move lever to "Opening and closing of tailgate".

## Electrical Connections

Connect cable for lights, indicators and brake lights into the sockets on the baler and tractor. Check that lights work correctly. It is necessary to have the electrics connected and the lights turned on before operating the baler in order to get the horn signal when tying begins (see page 16, Twine Wrapping).

### Connecting the Signal Box (RP 12)

Fix the mounting device for the signal box in the tractor cabin, and attach signal box. Connect plug of connecting cable to tractor.

The signal box for net wrapping has a green light switch which shows voltage and correct poles; if necessary change poles at plug or socket.

### Connecting the Signal Box (RP 12 S/15 S)

Fit bracket for signal box in tractor cabin and plug in control box. Connect plug of the connecting lead on the tractor. The signal box (fig. 3) has 2 illuminated pushbuttons (green/red), one buzzer and one selecting switch. The green illuminated pushbutton indicates the correct polarity and voltage on the machine and is used for engaging the net wrapping. The buzzer and the red illuminated pushbutton display the signal for engaging the wrapping. When the selecting switch is set to "automatic", automatic twine wrapping takes place after the pre-selected density has been reached. At the "manual" setting, either twine wrapping (red pushbutton) or net wrapping (green pushbutton) can be engaged at any time. For net wrapping the green pushbutton must then be held down until the net is gripped by the bale (indicated by the rotation of the netting roll). In the case of net wrapping, care must be taken that the selecting switch is in the "manual" position, so that unwanted twine entry is prevented.

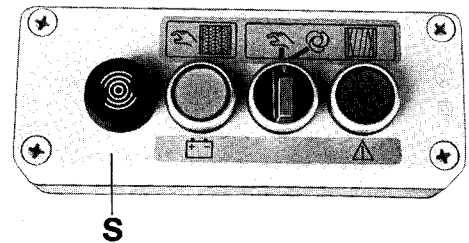



Fig. 1

1725-104

## TWINE TYING

### Inserting Twine Spools

 Insert and thread new twine spools only when the baler is stationary. Use baler twine of good quality only. See page 2 for Technical Data. Where bales are to be stored outside, plastic twine is recommended. Put four spools for RP 12 respectively six spools for RP 12 S / RP 15 S - A, B, C, D - upright, side by side into the twine box (fig. 2). Unless spools are inserted the right way round the twine tends to form loops and to tear. Pull twine end out of spool A from the top of the wrapping and tie it to the start of spool C with a simple knot. Tie spool B to spool D; always pulling the twine through the twine guides found above each spool.

The twine box on the left of RP 12 S / RP 15 S is for six reserve spools of twine or for one reserve roll of net or plastic foil.

### Threading the Twine

Before threading the twine move twine running indicator 5 (fig. 26) to the yellow mark on the left (in driving direction) by turning the pulley 1 (fig. 3), (starting position). Proceed by threading the twine as in fig. 2, 3 and 4 also see respective transfers on the baler. Pull twine out of spool B through the top guide eye in the twine box, through the rear panel of the twine box and through the twine tensioner 2. Correct tension of twine tensioner 2 must be set to a spring tension of 28 mm. Guide the twine through the fixed guide eyes in front and behind the stepped pulley 1 and then guide the twine through the second twine tensioner. Set twine tensioner at 23 mm.

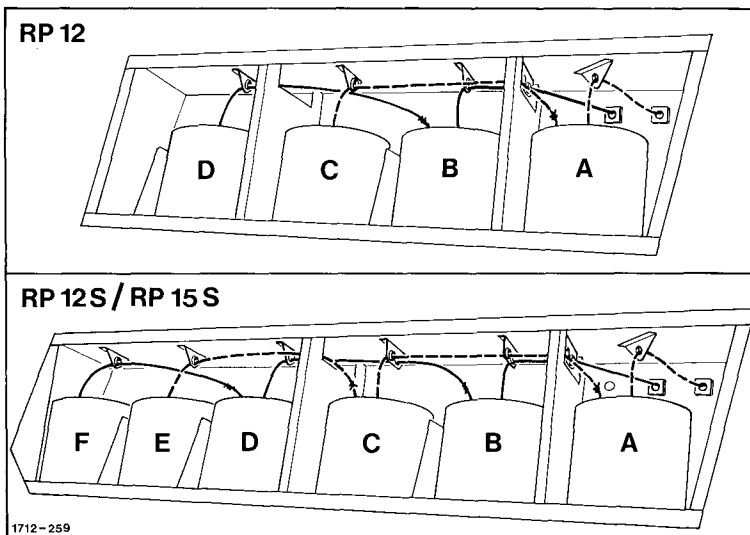

Fig. 2

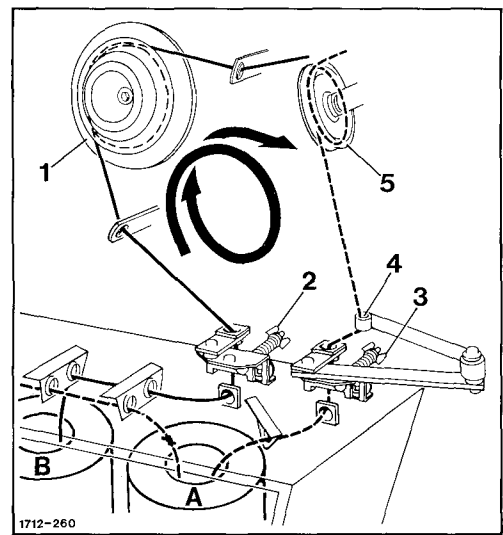

Fig. 3

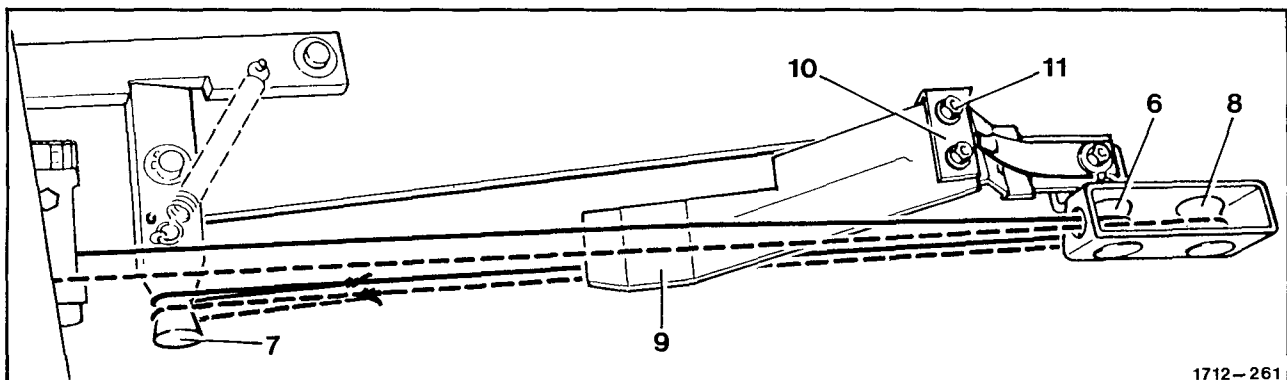

Fig. 4

1712-261

Further threading the twine behind the second twine tensioner, as shown in fig. 4. Lead the twine around roller 6 as shown. Tie a large loop on the end of the twine and attach the loop over roller 7. Pull the twine tight and wind it around the stepped pulley 1 (Fig. 3) 1 ½ times.

Pull twine A through the top guide eye in the twine box, through the rear panel of the twine box and through the twine tensioner 3 (fig. 3). Correct tension of twine tensioner 3 must be set to a spring tension of 25 - 28 mm. Thread the twine further through the spring loaded guide 4 and over roller 5. Guide twine as shown in fig. 4 around roller 8. Tie a loop to the twine end and also attach the loop to roller 7. Both legs of spiral springs have to be set before any twine is threaded as shown in fig. 5 to measurement E = 60 - 80 mm.

Note: The wrapping distance of twine on the finished bale can be pre-selected. This is decided by the runnage of twine around the pulley 1 (Fig. 3). Large pulley diameter makes a narrow twine wrapping distance. Small pulley diameter makes a wide wrapping distance of twine on the bale.

Check twine thrower 9 (Fig. 4) for correct setting. The measurement between the tightly tensioned twine and the front edge of twine thrower 9 must be 10 - 20 mm. If this is not the case, loosen bolts 11 and adjust angle 10 to twine thrower 9 so that measurement is within range of tolerance. Twine thrower 9 must go directly past wrapping unit frame. Lastly tighten up bolts 11 again.

**IMPORTANT:** Do not turn the pulley 1 (Fig. 3) after threading, for this will make the wrapping process start up prematurely.

 Never thread twine by hand while the machine is running! Stop the machine before putting twine around the pulley!

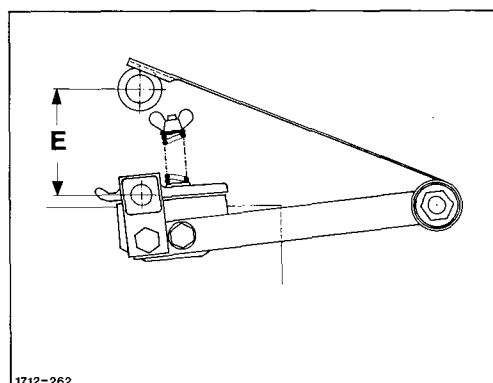

Fig. 5

## NET WRAPPING

### Inserting the Net Roll

Pull the net roll holder (in driving direction on the left) out of its retainer by the handle and insert into the cardboard core of the net roll. Push the net roll on to the net roll retainer (in driving direction on the right) and put the left net roll holder into the retainer. Tension the net roll by turning the handwheel 6 (Fig. 6). Push net tensioner 7 down, roll off net from the net roll 8 and push the netting over the net tensioner 7 and below tube 15 into the chute. The net must reach both rollers 9 and 10, to be certain that the rollers will transport the net into the baling chamber. After releasing net tensioner 7, it should be impossible to turn the net roll manually. If this is not the case, slacken bolt 11 at lever 12, tighten milled nut 13 by hand, retighten bolt 11. The net between the rollers 9 and 10 and the net roll 8 must always be taut. If the net is still slack, brake the net roll by further tightening up of the milled nut 13.

Hook tension spring 14 into the second chain link as seen from the spring.

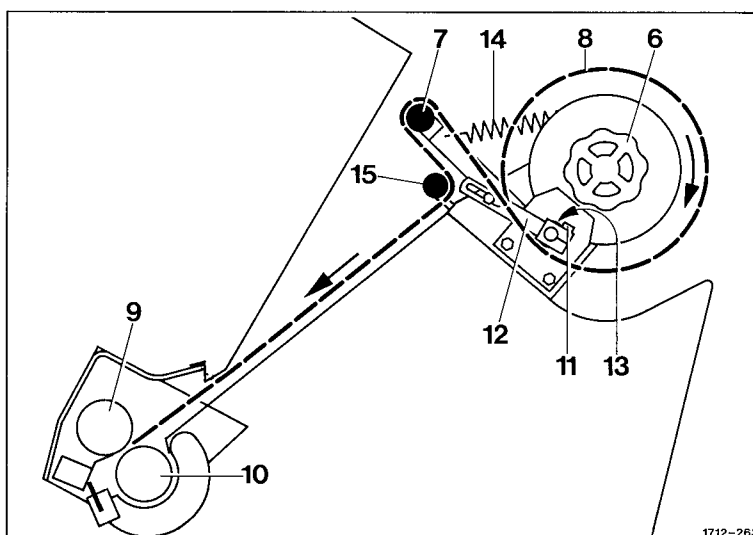

Fig. 6

The net wrapping unit is tensioned only by opening the tailgate. If, when the baling chamber is full, the net must be tripped without opening the tailgate, in the case of a fault or change of net roll, tensioning can be done manually with lever 16 (Fig. 7). Pull lever 16 forwards as far as possible. Tripping follows as normal by pressing the green pushbutton.

Selecting Number of Wrappings of Net

The number of wrappings of net on the round bales can be selected steplessly with selecting panel 17 (Fig. 7). After loosening the wing nut 18 (Fig. 7), set the selecting panel to get at least 2 wrappings of net around the bale. The scale found next to the panel 17 helps when selecting the number of wrappings. Adjust the upper edge of the selecting panel as on the scale.

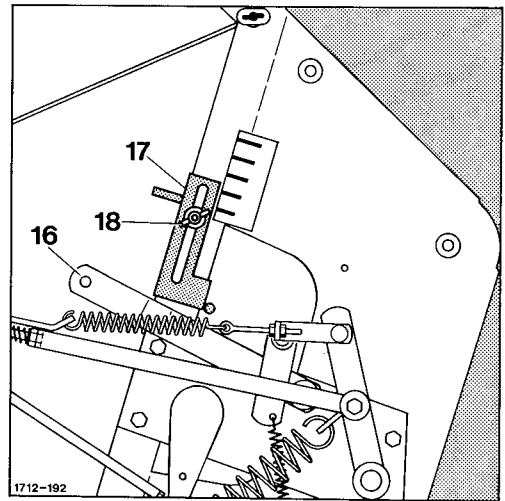

Fig. 7

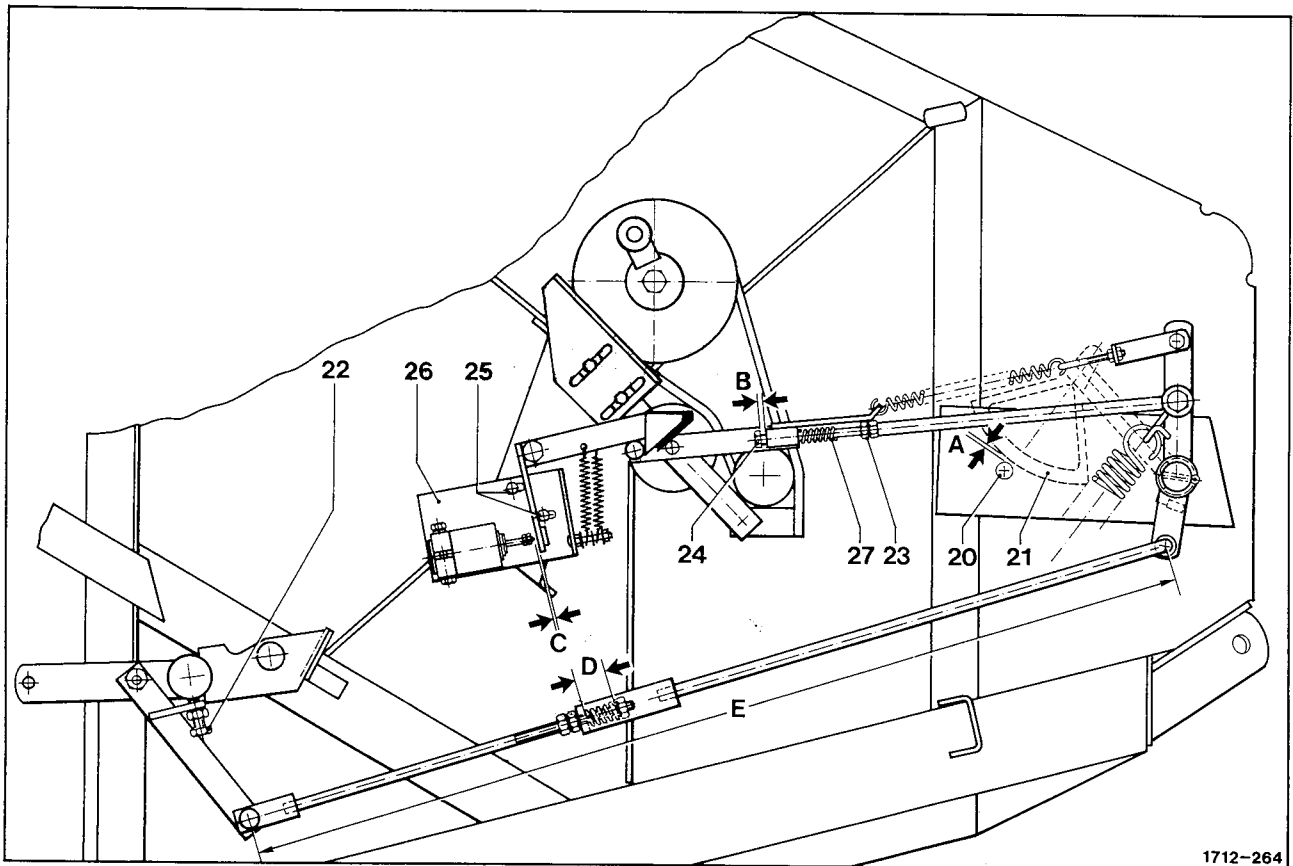

Fig. 8

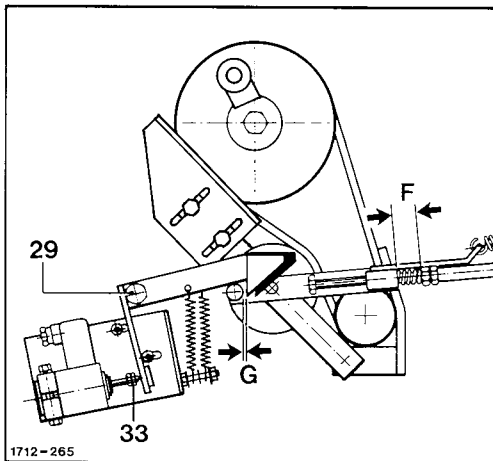

Fig. 9

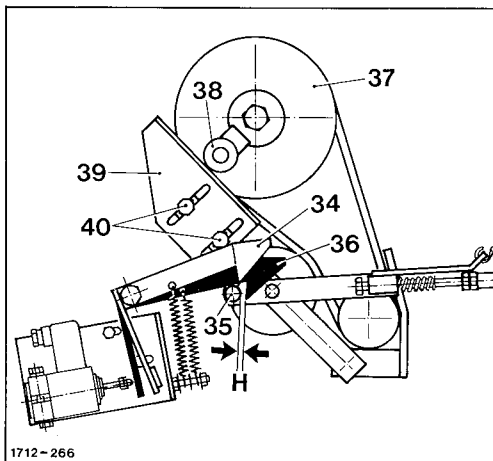

Fig. 10

### Setting

Usually the net wrapping unit requires no special adjustment or maintenance. However, if the settings given in Figs. 8 and 9 have changed, they can be readjusted as follows:

Check distances E and D (Fig. 8) when the wrapping unit is tensioned (V-belt is slack), correct if necessary. Distance E should be: for RP 12/12 S: 1030 mm; for RP 15 S: 1130 mm. Distance D should be 30 mm. Distance A, the space between the transporting roller 20 and the segment 21 must be 5 mm, if otherwise adjust with bolt 22. Distance B should be 3 mm, if otherwise loosen lock nut 23 and correct with bolt 24, then retighten. Distance C = 2 mm, if necessary, adjust nut 33 respectively by slackening bolts 25 and correcting fixing plate 26. When the wrapping unit has been tripped (V-belt tensioned), the spring 27 must be relaxed. Spring length  $F = 28 \pm 1$  mm (Fig. 9). Adjustments can be made by moving the turnbuckle 28 (Fig. 11). Distance  $G = 2$  mm (Fig. 9) is necessary for the catch to lock into position; if necessary loosen bolt 29 to correct this.

The knife must be tensioned for adjustment of the drive stop. To do this, tripping lever 16 (Fig. 7) must be pulled until segment 21 is resting on transport roller 20 (Fig. 8) and the outer ratchet lever 34 is resting on roller 35 of con. rod (Fig. 10).

**Attention:** Knife is under heavy spring tension.

Engage outer ratched 34 that tension roller 35 (Fig. 10) is secured by the second inner ratchet 36. Turn V-belt pulley 37 by hand until ball bearing 38 is resting in highest position on angle 39 (Fig. 10). In this position inner ratchet 36 must have 2 mm play between roller and ratchet (see measurement H in Fig. 10). In case of wrong measurement angle 39 can be adjusted accordingly after bolts 40 have been slackened.

If the net has not been cut off completely at the end of the wrapping process, check to see that the anvil and knife are parallel. To do this loosen the 4 countersunk bolts in the cover shield and remove the cover shield by pulling it downwards. Now loosen the 4 visible fastening bolts of the anvil and adjust until the anvil and knife are parallel again. Refit cover shield again with the 4 countersunk bolts and tighten. It is possible to turn the knife 3 times. The anvil can be turned once. While doing this, remove any paint which may be on the blade.

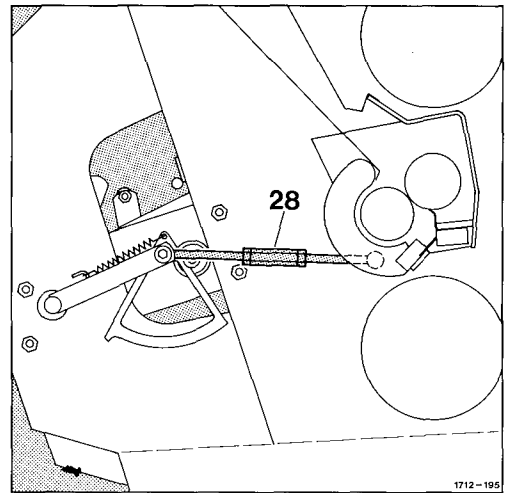

Fig. 11

#### Adjust Disc Brake

If the lining of the disc brake 30 is worn on one side (Fig. 13), loosen lock nut 31 and screw in bolt 32 until the brake discs are parallel again, retighten bolt 32. Readjust milled nut 13 (Fig. 6). (See paragraph "Inserting the Net Roll").

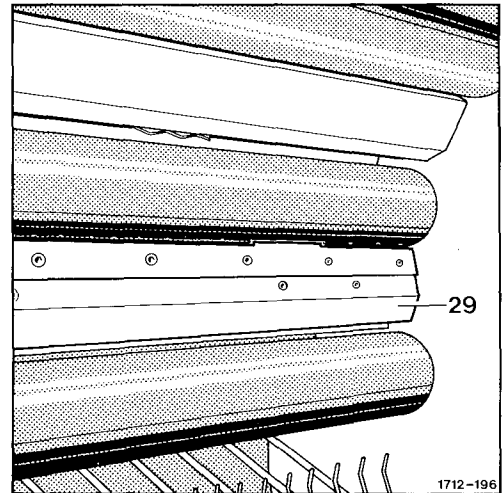

Fig. 12



**Warning!** Keep your hands away from the knife - danger of injury!

To clean inlet roller area the back shield 29 of the wrapping unit support frame (Fig. 12) can be removed from the baling chamber side.

#### Foil Wrapping

The net wrapping unit is also suitable for wrapping the round bales with foil (Polythene).

#### Servicing the Baler



Never carry out adjustments, repairs and servicing work while the machine is running. Stop tractor and wait for standstill of baler. Shut off PTO drive and remove universal drive shaft from the PTO shaft before carrying out work on moving parts of the machine. Use tailgate supports before entering baling chamber. Be careful when opening and closing tailgate! Nobody should stay within reach of the tailgate. See table of faults, page 24.

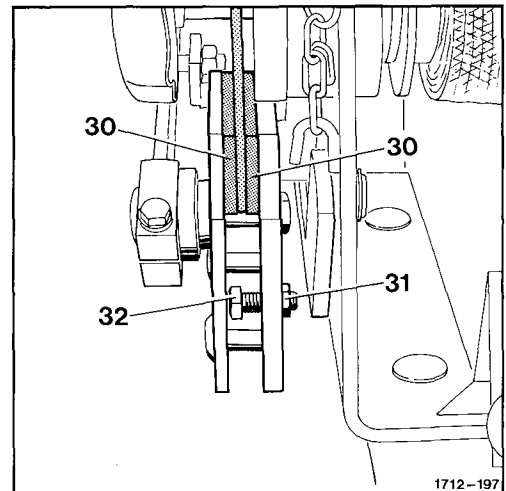



Fig. 13

## FIELD OPERATION

 The roll baler is well guarded against possible accidents, even so it is important to operate the baler with care. Check and keep all guards in place before starting to bale. Always stop the baler before making adjustments and maintenance. Take great care when opening and closing the tailgate. Nobody should stay in reach of the tailgate. Use tailgate supports before entering the baling chamber.

### Before Road Transport

Lift pick-up by means of the tractor hydraulics into its highest position (transport position). Close the locking valve on hydraulic hose. The pick-up is now hydraulically locked and stays in transport position. An extra safeguard for the pick-up is to keep the chain between the pick-up and side wall as short as possible.

### Setting the Bale Counter

To keep a correct count of ejected bales, the bale counter 2 must be set to zero with key 3 before operation (Fig. 14).

### Pre-set Bale Density

The required bale density can be pre-selected and set with adjusting lever 4 (Fig. 14). Connecting tension rope 5 into hole A results in low density, position B is for medium density and position C for high density.

### Windrowing

The machine works fast and smoothly at high output if windrows are uniform and not wider than 1,5 m.

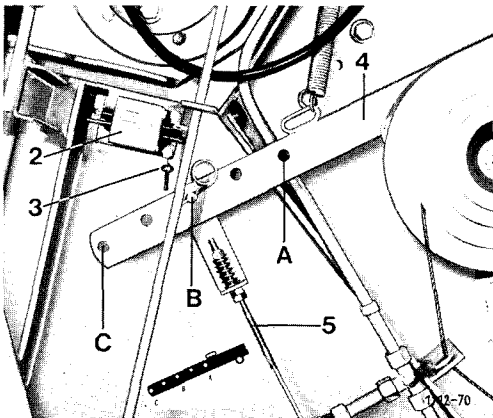
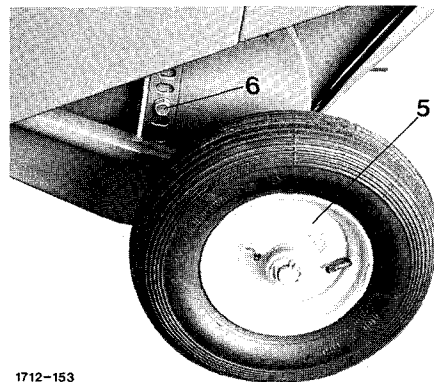

Fig. 14

### Pick-up Guide Wheel

Depending on required pick-up clearance, guide wheel 5 (Fig. 15) can be set higher or lower. Normal setting is for the pick-up tines to have 2 cm ground clearance in a working position (Distance G in Fig. 1). Bring pick-up to right height, support. Remove bolt 6. Set guide wheel 5 (Fig. 15) and tighten up again with bolt 6. Correct air pressure of guide wheel must be 1,5 bar.



1712-153

Fig. 15

### Setting Windguard

The windguard 1 (Fig. 17) is fitted movable above the pick-up. The swinging height of the windguard is steplessly movable according to the size of the windrow to allow perfect guidance of the baling material into the roll chamber. Only with very small windrows it is necessary to adjust the windguard 2 on holder 9 into the bottom position to have a smaller clearance between windguard and pick-up tine.

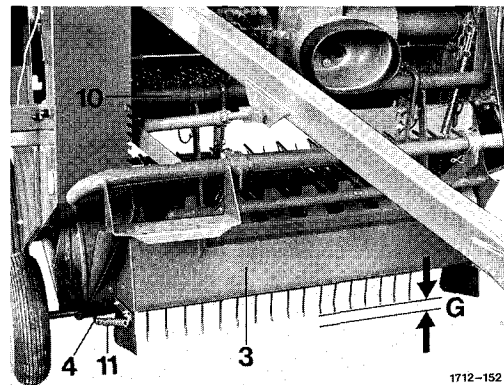

1712-152

Fig. 16

### Pick-up Cover Shield

The pick-up cover shield, which is available as optional equipment, prevents short stalk material from rolling away ahead of the pick-up. Fit cover shield 3 as seen in Fig. 16 with both hooks on to the cross tube 10 and secure with safety clips. Fit hook 4 in tension spring 11 on both sides - as shown - to the lower segments of the pick-up cover shield.

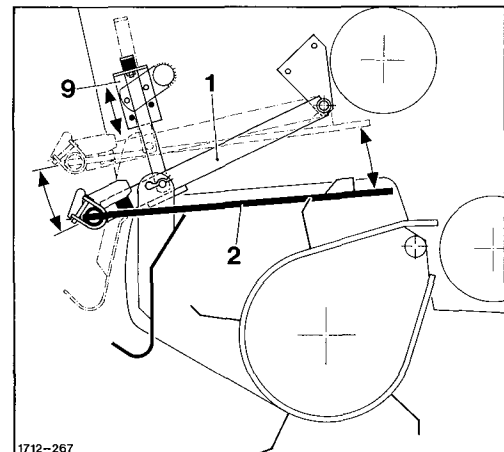

1712-267

Fig. 17

### Wide Pick-up (Optional Equipment)

As optional equipment the RP 12 S / 15 S are available with a 2 m wide pick-up. The two side augers and a transport roller guarantee even flow of baling material into the roll chamber. The pick-up is fitted with a fully automatic cam type cut out clutch against overload.

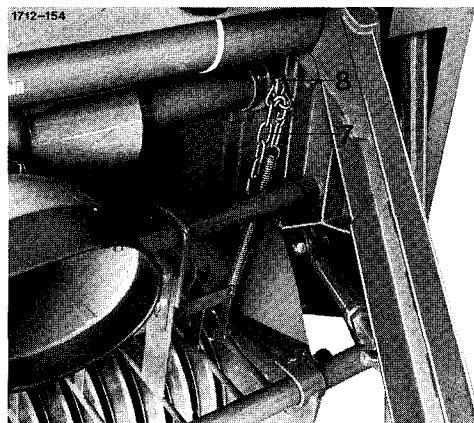

1712-154

Fig. 18

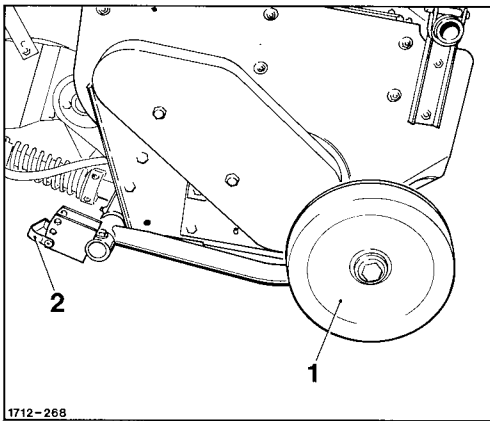

Fig. 19

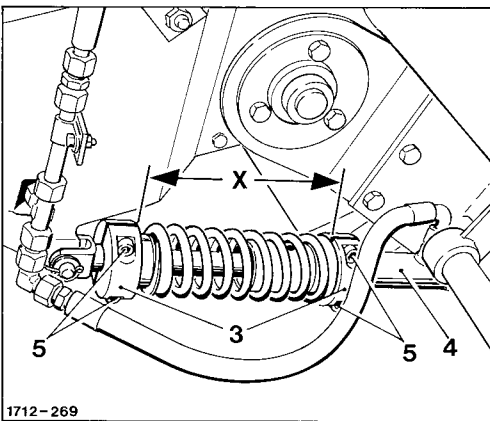

Fig. 20

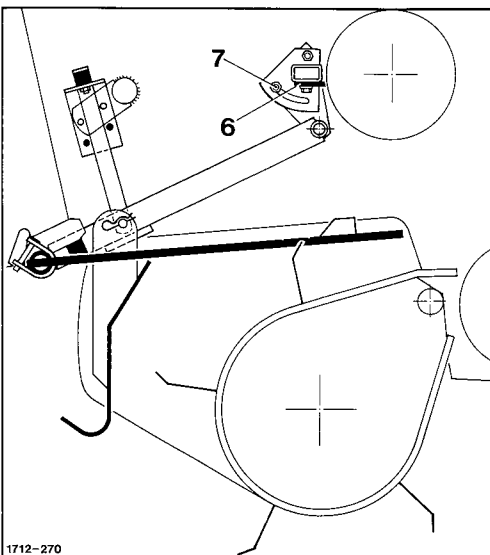

Fig. 21

The setting of ground clearance is done by two adjustable guide wheels (Fig.19). Remove pin 2 and set guide wheel 1 by lifting or lowering into the required position, re-fit pin 2. A mechanical adjustable spring relief of the pick-up guarantees a perfect pick-up guide (Fig. 20).

#### Adjustment of Pick-up spring relief (Wide Pick-up)

To obtain a perfect ground clearance the wide pick-up is fitted additionally to the guide wheels with a spring relief and pick-up guide system. With fully lifted pick-up and released spring the measurement X between the clamping pieces 3 should be 215 - 220 mm (Fig. 20).

The clamping pieces on the cylinders 4 can be shifted if a correction of measurement X is necessary. To make this adjustment the pick-up has to be lifted by tractor hydraulic into highest position and must be supported. Slacken bolts 5 and move clamping pieces 3 on cylinder 4 until measurement X is reached. Re-tighten clamping pieces 3 and bolts 5.

#### Scraper RP 12 / 12 S

For baling silage a special scraper 6 is fitted on the roller above the intake opening. The scraper 6 must be fitted as close as possible to the roller if baling material is wrapping around the intake roller. For adjustment loosen bolts 7 and shift scraper 6 to approx. 1-2 mm distance to the roller. Re-tighten bolts 7 again.

#### Feed Guide Plate

We recommend the use of the feed guide plate, which is supplied with the equipment, for certain crop and operational conditions, above all for using the net wrapping unit and for short, brittle crops which spill out of the feed opening.

Take the feed guide plate out of the twine box and insert from the baling chamber into the hole on the left (in driving direction) behind the first roller, then insert the peg with fixing strap into the hole on the right (in driving direction) and tighten up with a bolt M 10.

### Setting Pick-up Height

Lifting and lowering of the pick-up is operated by the tractor hydraulics. Once in the field move the pick-up from transport to working position. Avoid ground contact of tines. Distance G in Fig. 16 should be 2 cm. Position chain 7 (Fig. 18) into hook 8 to prevent the pick-up from going down too far into dips in the ground.

If ground clearance is not sufficient, fit extension blocks between the axle and frame (see page 3, Attaching the baler).

Do not remove clogging by lifting the pick-up hydraulically. See table for Operational Faults and quick Remedies.

### PTO Speed

Drive the baler only with standard 540 r.p.m. Some tractors with P.T.O. speed of 1080 r.p.m. should only be driven with half the engine r.p.m. If very dry and short material is baled, the PTO speed can be cut down to approximately 350 - 450 r.p.m. When baling short and damp material the PTO should not be turned off.

### Negotiating Bends

Never exceed more than 80° on wide angle joint of PTO drive shaft (tractor side) when taking sharp bends, whether the PTO is rotating or not, otherwise danger of breakage.

### Good Driving

To obtain high output and well-shaped round bales, the bale chamber should be fed evenly with material over the entire baler width. Good driving greatly contributes to steady, smooth feed. If windrows are narrower than the pick-up width, drive alternately along the right and left sides of the windrow to ensure uniform chamber feeding (Fig. 22).

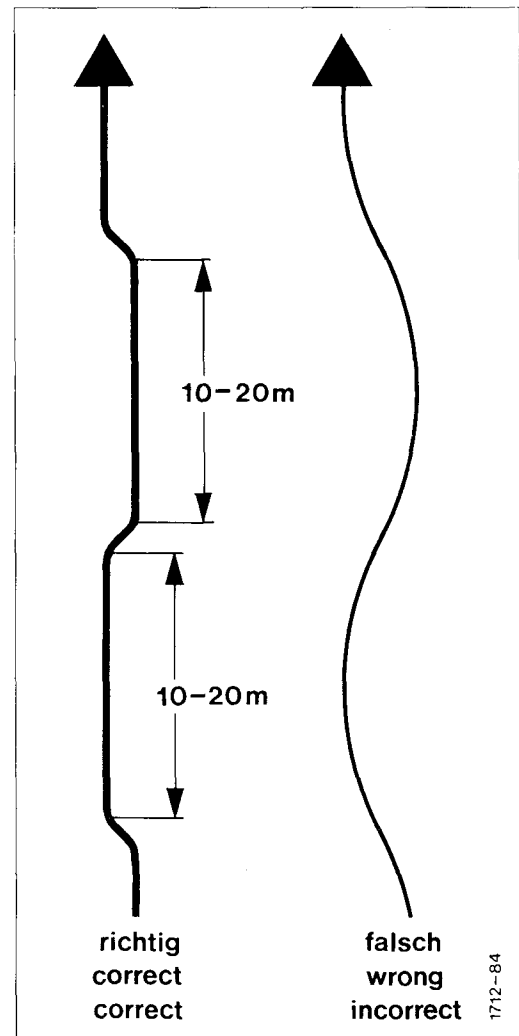

Fig. 22

## Locking the Tailgate

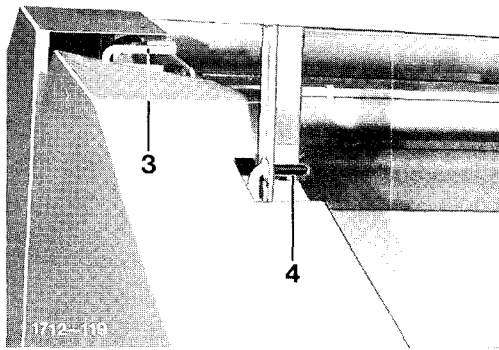

Fig. 23

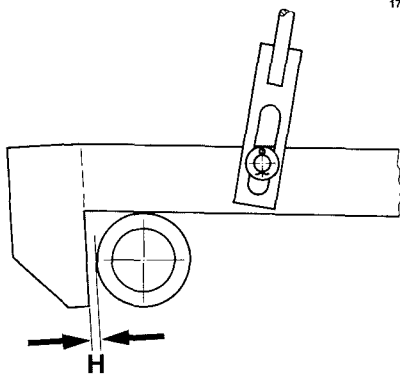

Fig. 24

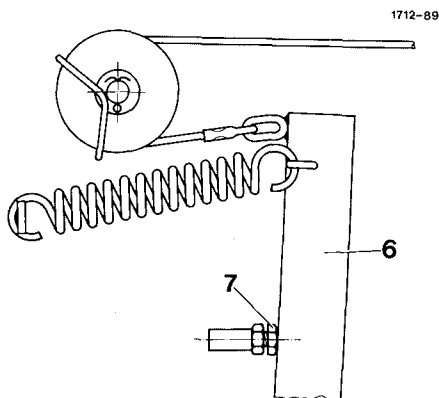

Fig. 25

1712-106

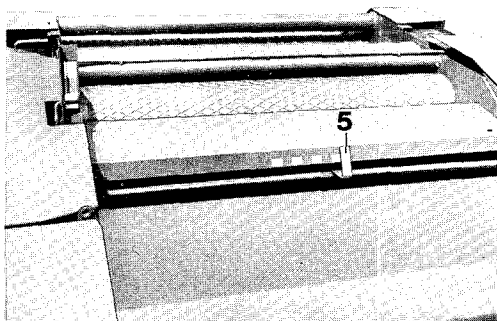

Fig. 26

Before picking up the material and after each bale ejection, the tailgate must be locked properly. Keep hydraulic valve on tractor in "lower" for a short time. The tailgate will lock automatically. The tractor driver can see this when the tailgate lock indicator 3 as seen in Fig. 23 is in the upper position. If the tailgate is open or not locked properly, the indicator 3 is retracted into the lower position.

To have the tailgate securely locked, the following measurements between the hook of the locking frame and the holder on the tailgate should exist (see distance H in Fig. 24): On the right hand side in driving direction, distance H = 3-8 mm; on the left hand side in driving direction, distance H = 15 - 20 mm.

To deal with deviations the position of the locking frame 6 can be adjusted with bolt 7 (Fig. 25).

## Bale Density

The density of the round bale depends on the material and compaction pressure. The density is widely variable and can be pre-set on the baler (see page 11). Within the pre-set range the tractor driver can observe from the tractor seat the filling indicator 4 (Fig. 23), which level of filling the baling chamber has reached.

## Wrapping the Bale

When the pre-set bale density has been reached (see page 12), this fact is signalled to the tractor driver visually and audibly on the signal box. Depending on the position of the selecting switch the signal box S (Fig. 1), wrapping of twine/net is engaged via the pushbutton or automatically, by RP 12 only automatically. When the twine has been drawn in - this is shown by the twine running indicator 5 (Fig. 26). (By RP 12 with switched on tractor position lights and connected connection cable additionally by a buzzer signal) the tractor driver stops forward travel.

The PTO must be kept running but without material entering the baler; the wrapping process takes place automatically. In case of net wrapping, stop forward travel, engage net wrapping unit by pressing the green illuminated push-button and allow net to enter together with last crop on the pick-up. When the net roll respectively the twine indicator stops at the left hand marking (in driving direction) the wrapping process is completed and the new starting position reached. The twine guide shield below the wrapping unit assists the twine to fall into the roll chamber. It must be kept clean of dust and straw at all times.

Wrapping of the bale cannot only be started on RP 12 S / 15 S after reaching the pre-set density but also at any time by pressing the pushbutton on the signal box.

If there is a failure in the power supply of the system, the net wrapping unit can also be tripped by hand by pulling the tripping rope. To do this fix the supplied rope 12 (Fig. 27) to the lever 13 and lead through the twine guide eye 14 to the tractor. Fasten it so that it can be pulled easily. As soon as the selected density has been attained, which can be seen on the setting of the filling indicator, the net wrapping unit is tripped by a short pull on the tripping rope. Net wrapping then takes place automatically.

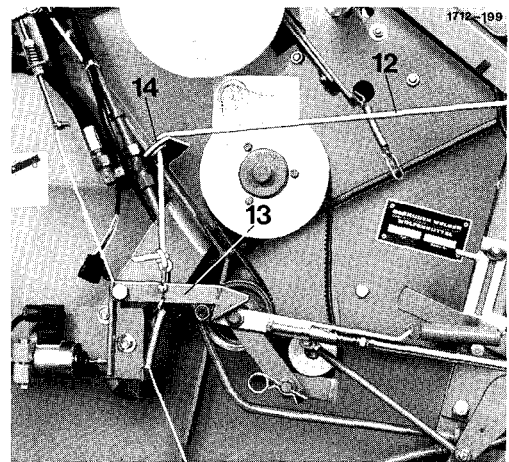

Fig. 27

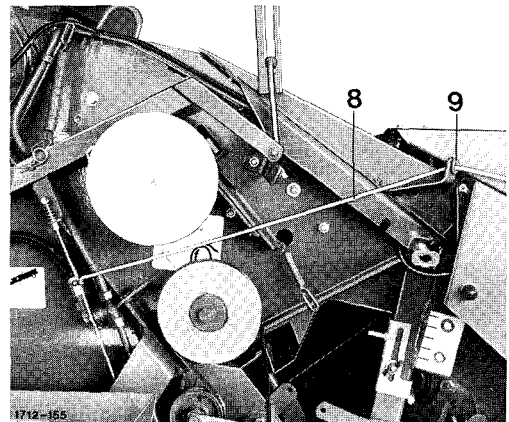

Fig. 28

Wrapping Unit - Hand Tripping for Wrapping with Twine RP 12

Rollbales which are not finished because not enough baling material is left to reach the pre-set density are not automatically tripped. In such cases the tractor driver has to trip the mechanism by hand. To do this mount the supplied hand-tripping rope 8 as in Fig. 28

(RP 12): Tightly knot one end to the steel pull rope at the level of the wire rope clamp, pull the other end through the guide eye 9 (RP 12) (Fig. 28) and lead it to the tractor. Fasten the tripping rope 8 here so that it can be pulled easily. If necessary, the wrapping unit can be tripped by hand by a short pull on the rope. If the wrapping unit is to be tripped without the rope, this is possible by lifting the filling indicator 3 (Fig. 23) as far as it will go.

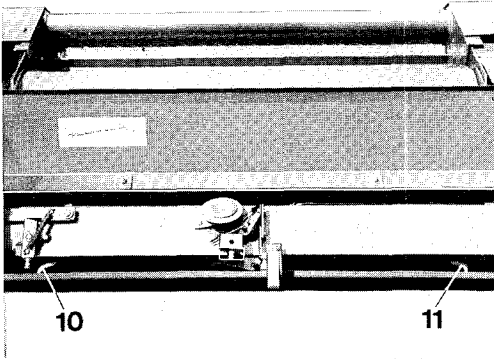



Fig. 29

 To do this, stop forward drive and stop the baler before the filling indicator 4 (Fig. 23) is moved by hand. After the PTO has been turned on, the wrapping process is automatic until the twine is cut.

#### Setting of End Wrappings

For setting the end wrappings on the rollbales, adjust the range spacers 10 and 11 in Fig. 29. When baling very dry material which prevents the bale ends from being filled out properly, the range spacers 10 and 11 should be moved further inwards. Open wrapping unit cover. Lift range spacers 10 and 11 by hand and then move them sideways. Six different rest positions for each spacer are possible. Close the cover after adjustment.

#### Bale Ejection

Keep PTO running when bale has been tied. Open the tailgate hydraulically for the bale to roll out. Drive forward slightly before closing the tailgate, so that the tailgate does not close on to the deposited bale. Keep hydraulic valve in "lowering" until the tailgate is completely closed and locked (see Fig. 23). The next bale can then be started.

When using the bale discharge extension (optional equipment, also for supplementary fitting) the bale rolls far enough away from the baler to eliminate driving forwards before closing the tailgate.

**ATTENTION:** The opening time of the tailgate should be for safety reason never be below 3,5 s, otherwise contact SERVICE DEPT.

 When working on hilly ground, make sure to discharge the bale across the run of the slope. Nobody should stay within reach of the tailgate.

### Overloading safety

Shear bolt 1 (Fig. 30) is built into the cross shaft to safeguard the main drive of the RP 12 against overloading. When replacing only use bolt of same quality! Push guard 2 to the side after loosening wing nut 3. Remove remains of old shear bolt, replace with a new one, tighten with 2 hexagonal nuts. Fasten down guard 2 again. Spare shear bolts and nuts are included in tool kit.

Instead of the shear bolt, the RP 12 S / 15 S are supplied with a fully automatic cam-type cut out safety clutch in the universal drive. When overloading takes place the turning moment is interrupted. When PTO speed is reduced or switched off, the turning moment builds up again and the machine can be started up again immediately. Long and frequent overloading should be avoided.

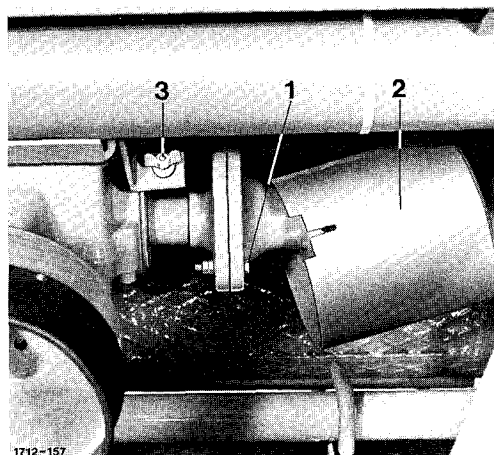



Fig. 30

### SERVICING THE BALER

 Never carry out adjustments, repairs and servicing work while the machine is running. Stop tractor and wait for standstill of baler. Shut off PTO drive and remove universal drive shaft before carrying out repairs on drive parts. Use tailgate supports before entering baling chamber. Be careful when opening and closing tailgate! Nobody should stay in reach of the tailgate.

Look after your baler with care and always observe the specified servicing intervals to ensure cost-efficient operation and a long life, to prevent premature repairs and maintain the baler's value.

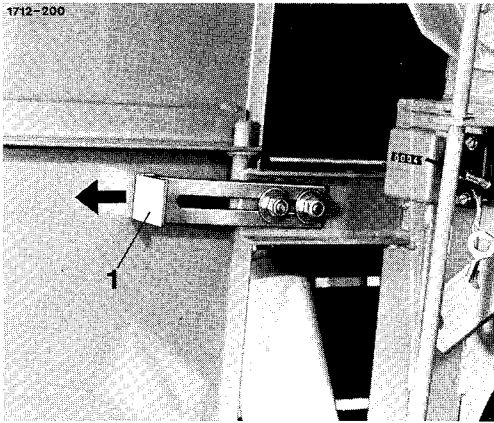

Fig. 31

### Tightening Bolts

After approximately 20 operating hours, firmly tighten up all nuts and bolts.

### Checking Road Wheels

Check to see that wheel nuts and wheel caps sit tight. Check tyre pressure which should be 10,0/75-15.3 Impl. 6 PR = 2,3 bar for standard tyres and 11,5/80-15.3 Impl. 6 PR = 2,0 bar for special tyres. Tyre pressure for pick-up guide wheel should be 1,5 bar.

### Chain Lubrication

Lubricate all chains regularly. Open side guards and stop with a rod (RP 12) or bar (RP 12 S / 15 S). Pull out bar 1 after opening the guards (Fig. 31). Lubricate chains only when the machine has stopped. Use chain saw chain oil or greasing spray. After lubricating the chains close all side guards and secure. Central chain lubrication, which is available as optional equipment, reduces servicing time and effort. Check level of oil tank daily, add chain saw chain oil if necessary. Open the middle guard door on the left side of the machine to reach the oil tank. Adjust the brushes of the central lubrication so that they are in contact with the chains.

### Guide Bar Lubrication

Guide bars for guiding the tailgate are fitted on both sides of the baling chamber; lubricate the inner sides of these with multipurpose grease.

### Changing Gearbox Oil

The oil in the gearbox must be changed after every season. Take off filling cap with breather, remove drain plug, drain out old oil into a container. Remove screw plug from oil level inspection hole. Clean drain plug and refit. Fill with approx. 1,65 litres of gear oil SAE 90 until oil comes out of the inspection hole. Refit caps on oil inspection and filling holes tightly. Check oil level regularly.

## Chain Tension

Chains for transmission, lower section roller drive and pick-up drive must be checked and tensioned occasionally. Loosen chain tension blocks, re-tension in slots and re-tighten. Chains for top section drive as well as for tailgate drive are tensioned with springs 4 (Fig. 32). Top drive section: Tighten spring according to gauge indicator (distance X).

Tailgate drive RP 12/12 S: Tension upper springs according to gauge indicator (distance Y).

Tailgate drive RP 15 S: Tension all 3 springs according to gauge indicator.

If the chain tension range is exhausted, shorten the chain by removing one link. If necessary insert a cranked chain link from the tool box.

## Safety Arrangements

 Keep flashing indicators and rear lights clean at all times and make sure they are never obscured by overhanging crop material. Check lights for correct functioning. Always carry the 2 chocks supplied in the twine box. If maintenance or fitting work is to be done with the tailgate open, the tailgate must be supported for safety reasons. Do this with the cylinder supports 5 found on both sides of the machine (Fig. 33).

After maintenance or fitting work, bring supports 5 back to their original position.

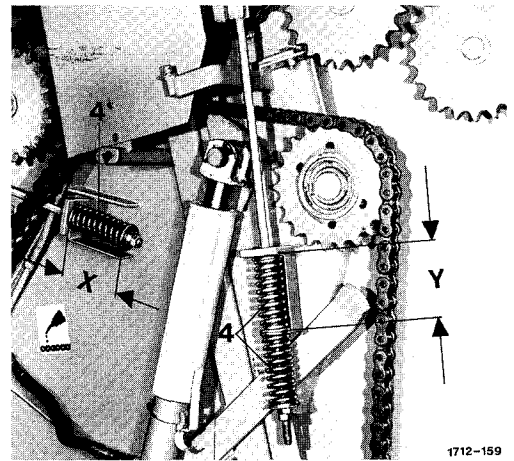

Fig. 32

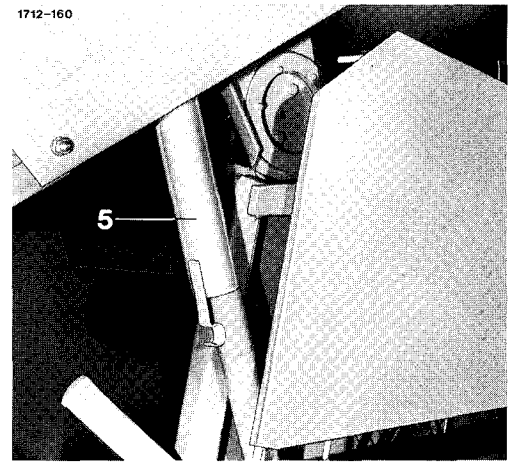

Fig. 33

## OUT OF SEASON STORAGE

Clean baler thoroughly. Clean all chains and lubricate. Soak rollers covered with dirt and stalks with water and clean them afterwards with a strong water jet with the machine running.

Attention! Fit tailgate supports before standing in reach of the tailgate.

Clean and inspect the net wrapping unit. From inside the baling chamber loosen the 4 countersunk bolts, so that the covershield 29 (Fig. 34) can be pulled downwards. Free the wrapping area from dust and remains of crop material. Using a cloth soaked in oil, reach between the net wrapping unit frame and the roller to grease the anvil (See Fig. 35).

Attention: Do not grease the roller.

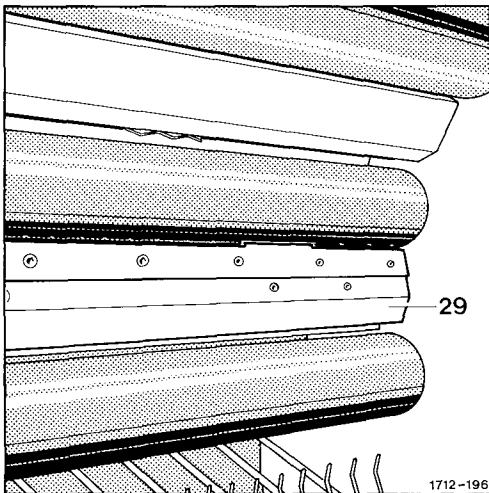

Fig. 34

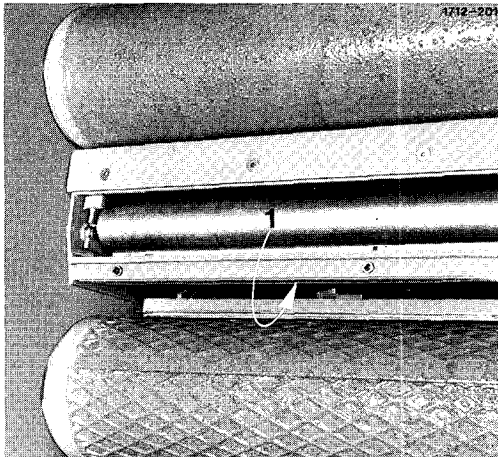

Fig. 35

## Optional and Extra Equipment

-----

### Wide Pick-up

To ensure correct picking-up of the crop even with large windrows, the RP 12 S / 15 S can be equipped with a wide pick-up.

### Automatic Chain Lubrication

If required the baler can be delivered with automatic central lubrication. Servicing work is greatly reduced by this and the life of the chains prolonged.

### Net and Plastic Foil Wrapping

Net wrapping has several advantages: The wrapping cycle is reduced, leading to an increase in output; there are only minimum losses caused by material breaking up and the closed surface means that the bales are even less sensitive to rain, hail and snow.

### Bale Discharge Extension

Using the bale discharge extension eliminates the need to reverse the baler to eject the bale (Standard equipment for net wrapping unit).

### Reduced Speed of Rollers

For smaller tractors up to 48 kW (65 hp) a conversion kit to reduce the speed of the rollers is available.

### Oversize-Tyres

Oversize tyres are available for special purposes instead of standard tyres: 11,5/80-15.3 Impl. 6 PR; 15,0/55-17 Impl. with a track with of 2,0 m.

### Pick-up Cover Shield

The pick-up guide shield guarantees excellent picking-up of short stalk material.

### Hydraulic Remote Control

If the tractor has only a single-acting valve, the tailgate or the pick-up can still be operated from the tractor with the hydraulic remote control.

## TROUBLE-SHOOTING MADE EASY

It is not possible to provide accurate instructions for all possible cases, due to the different operating conditions. Ground conditions, windrow thickness, condition of the crop, inexperienced or insufficient care of the machine can all lead to difficulties.

For difficult cases, with which you cannot cope yourself, your local WELGER dealer is at your disposal. Generally, however, you will be able to manage with the help of the table below.



Before faults are corrected, stop the p.t.o. shaft and the tractor engine and wait until all moving parts have stopped.

Never try to correct faults - for example in the area of the feed opening - while the machine is running.

No.	Fault	Possible cause	Remedy	Remarks
1	Baling material is not picked up cleanly	Pick-up not low enough	Adjust pick-up height	see page 15, Adjusting pick-up
		Wrong position of windguard	Adjust windguard	see page 13, Windguard adjustment
		Pick-up cover shield not used when baling short crop	Use cover shield when baling short crop	see page 13, Pick-up cover shield
		Insufficient pick-up on uneven ground	Correct setting of pick-up guide wheel or fit second guide wheel	see page 13, Pick-up guide wheel
2	Baling material is clogging between pick-up and roll chamber	Wrong windguard setting	Adjust windguard	see page 13, Windguard adjustment
		Travelling speed too high	Slow down until bale is started	
3	Tailgate is opening and material is dropping out of roll chamber	Tailgate is not closed correctly	Observe mechanical closing device of tailgate. Hold tractor valve longer in "lowering" position	see page 16, Locking of tailgate
4	Slippage between bale and roll chamber	Extremely dry or slippery, smooth material	Reduce bale density	see page 16, Bale density
5	Uneven bale shape	Improper driving	Drive according to instruction	see page 15, Good driving practice
6	Loss of short material	On very dry material PTO speed too high	Cut PTO speed to about 350-450 r.p.m. Avoid unnecessary running of baler in neutral	see page 15, PTO speed see also no. 4
		Travelling speed too slow	Increase travelling speed	
		Windrows too small	Bigger size windrow	

No.	Fault	Possible cause	Remedy	Remarks
7	Twine is slipping off bale	Uneven shape of bale	Drive according to instruction	see page 15, Good driving practice
		Incorrect wrapping of short material	Do not put twine wraps too close to the ends of bale	see page Setting end wrappings
8	Wrapping unit does not start after tripping	Twine for the drive did not get caught by the bale	Check function and setting of twine thrower	
		Twine for the drive missing	Thread new twine	
		Reserve loop is missing	Adjust setting of tripping lever and twine carriage	
9	Wrapping unit is tripped but there is no visual or audible signal. Twine thrower fails to inject twine	Distance of switch to tripping lever is too great	Adjust switch	
		Twine thrower incorrectly set	Correct twine thrower setting	see page 6, Threading the twine
10	Twine is running out of roll chamber	Slippery baling material, twine slips off	Let twine enter roll chamber before stopping baler	see page 16, Wrapping of bale with twine
11	Both twines are running next to each other	Guide eye 1720.39.03.30 is not function correctly	Correct function of guide eye	
12	Several twines accumulate close to the bale center on the left hand side in driving direction	Trap lever pushes twine out of twine guide eye	Readjust twine level	
13	Twine carriage stops close to the side wall on the left hand side in driving direction	Material build-up in the reach of the twine carriage respective twine carriage has contact when passing through the side wall	Clean out material built-up. Adjust wrapping unit holder	
14	Wrapping cycle is finished but one twine not cut off	Wrong threading of twine. Twine for the drive mistaken	Re-thread correctly	
15	The second twine falls involuntarily into bale chamber	The twine clamping device does not grip the twine properly	Adjust clamping device	
		Spring is tensioning twine	Adjust tension spring correctly	see page 7, fig. 5
		Uneven twine thickness is used	Use even twine thickness	

No.	Fault	Possible cause	Remedy	Remarks
16	Heavy going shear pin breakage in cross drive safety device acts	Density too high	Change adjustment	see page 16
		Build-up material on rollers	Clean rollers with water jet	see page 22, Out of season storage
		Starting to slip	Reduce bale density	see page 12, pre-set density
		Tripping mechanism not correctly set	Check setting, change if necessary	see page 16, Bale density
		Wrong quality shear bolt	Use original WELGER shear bolt only	Order no. for shear bolt RP 12: 0901.10.78.00
17	Net or foil is not running into the baling chamber	Net or foil is not being gripped by the rollers	Roll off some net or foil from roll and lead it to rollers	see page 8, Inserting the new roll
		Too much tension on net brake	Slacken net brake	see page 8, Inserting the net roll
18	Net or foil is not being cut properly	Anvil and knife are not parallel	Reset anvil	see page 9/10, Setting
		Knife is damaged or worn down	Check knife, turn if necessary	
19	Net or foil roll keeps running after wrapping process has ended	Not enough tension on net brake	Increase tension on net brake	see page 8, Inserting the net roll
20	Net or foil is wrapping itself around the rollers	Stripping plate is bent	Check stripping plate, renew if necessary	see page 9/10 Setting. Do not remove net or foil from the rubber rollers with sharp pointed objects



## INSTRUCTIONS FOR TRAVELLING ON PUBLIC ROADS

The roll baler is an agricultural trailed appliances. Its operation does not require a licence in Germany, but an electric lighting system must be fitted. This is already permanently installed on your WELGER-Baler. When travelling on public roads and lanes, the lighting regulations for trailed appliances must be observed. For this purpose the connecting cable supplied with each baler must be plugged into the sockets on the tractor and the machine. The correct functioning of the lighting system should be checked regularly. In addition, all indicating lamps, brake-, rear- and side lights as well as the reflecting rear and sidelights must be kept clean. Care must also be taken that the lights are not obscured by trailing crops.

The maximum travel speed on public roads and lanes is 25 kph (15 mph).

The two chocks, which form part of the safety equipment, must always be carried on the baler.

### TRACTOR AND MACHINE NOISE

EC Directive 86 - 188 - EEC and UK Noise at Work Regulations 1989 place responsibilities on employers and employees to assess and control noise at the workplace.

Noise level during normal field operations will vary depending on the noise level of the tractor and the working conditions of the baler.

Bystander noise level and the noise at the drivers head position generated by WELGER balers with tractor cab windows open will normally be less than 90 dB (A).

The combined baler / tractor noise level will depend on total tractor noise (radios are a source of noise).

We recommend that the tractor is operated with the cab windows closed.

véhicule tracteur  
min. fusible de 10 A à action retardée

Schéma de circuits - Boîtier de signalisation

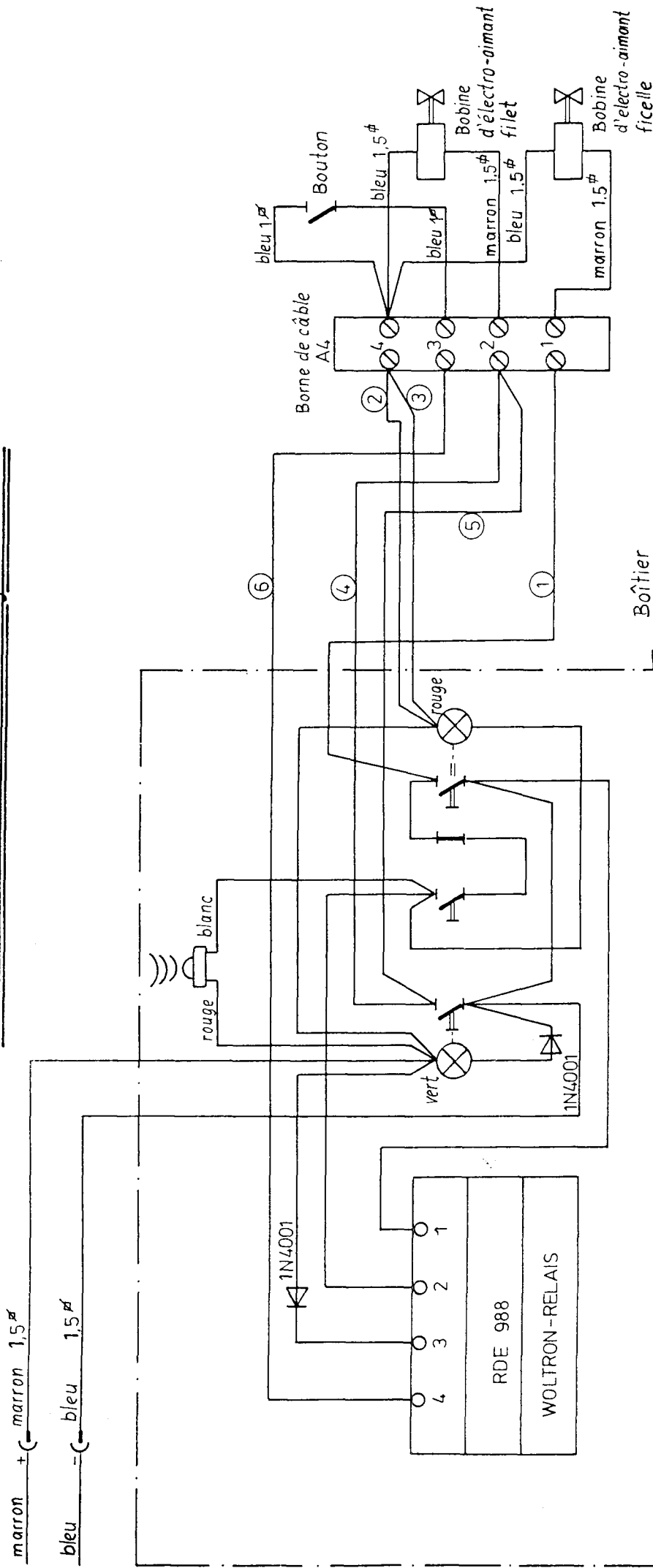

- ① ou marron
- ② ou noir
- ③ ou rouge
- ④ ou bleu
- ⑤ ou blanc
- ⑥ ou vert

Exemple:  
④ nombre de brin du câble... (tous 1,5 mm<sup>2</sup>)

Pour modèle: RP12 S/RP15S

Pulling Vehicle (Tractor)

min. fuse 10A (slow)

### Wiring Diagram - Twine - Net Tying Unit

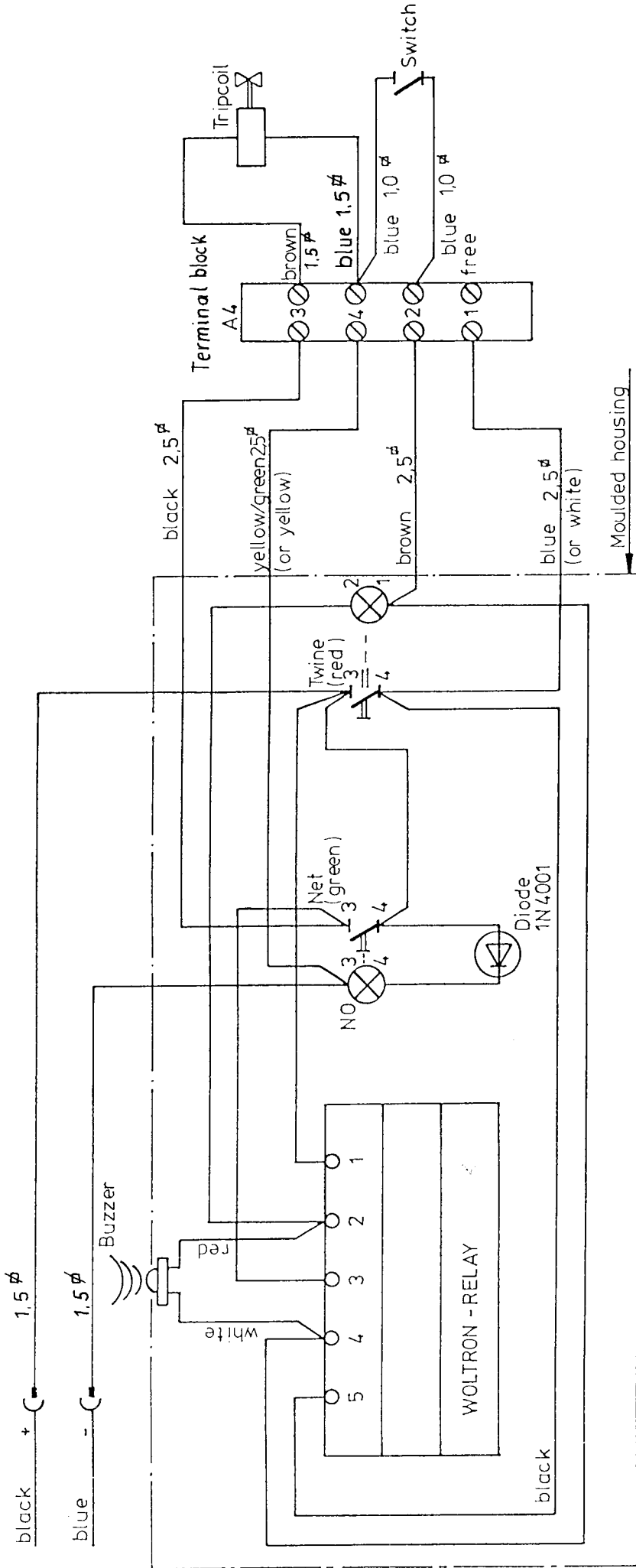

### Signal - Horn

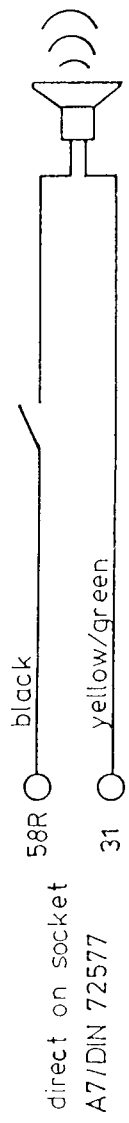

For Model: RP12

Wiring Diagram - Lighting

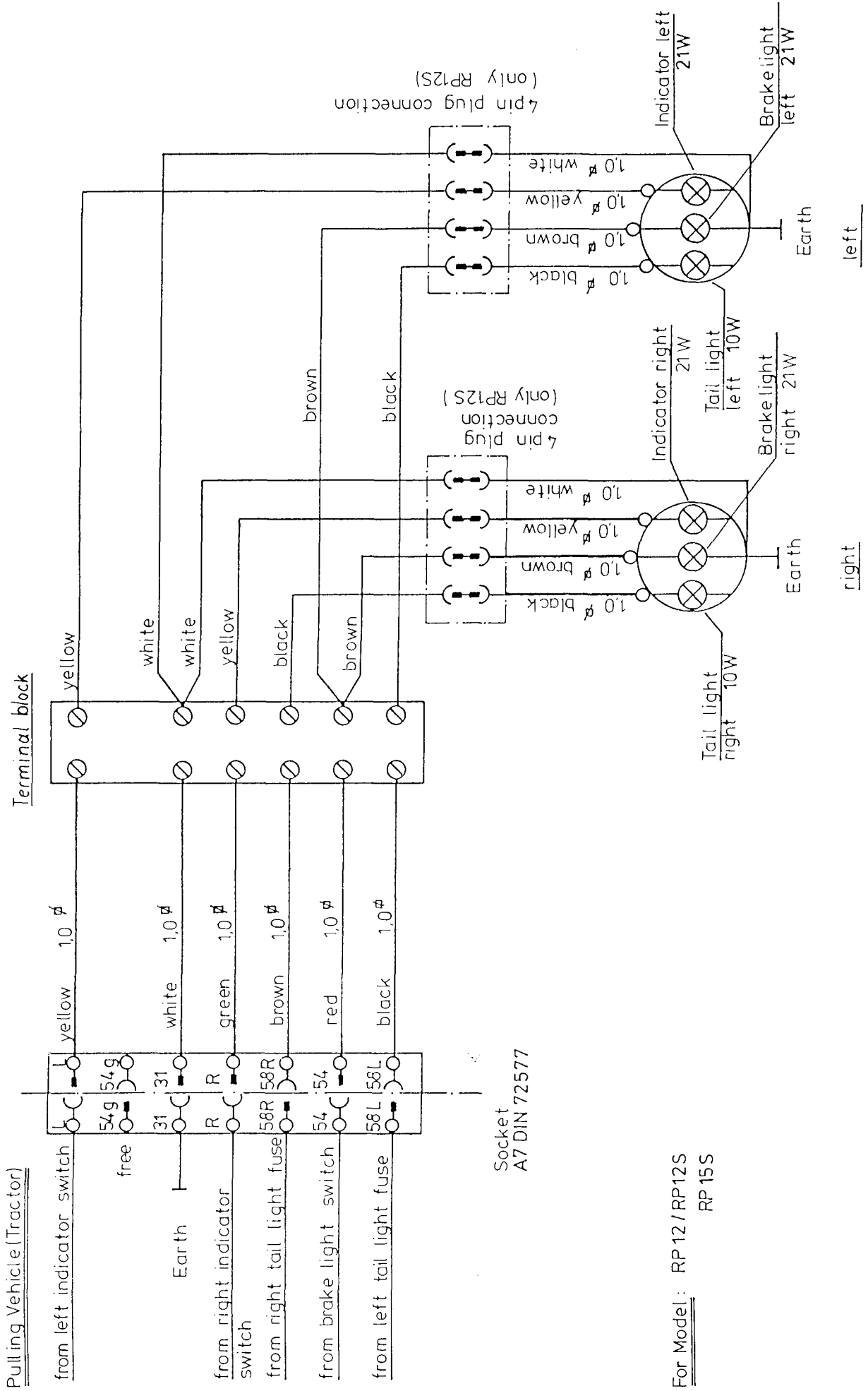

For Model: RP12 / RP12S  
RP15S