

Surface Wrap System (Serial No. EX880001-)



JOHN DEERE

OPERATORS MANUAL

Surface Wrap System
(Serial No. EX880001-)

OME87620 Issue K5 English

John Deere Ottumwa Works

OME87620 Issue K5

(This manual replaces OME82445 H2)

LITHO IN U.S.A.
ENGLISH



Introduction

READ THIS MANUAL carefully to learn how to operate and service your machine correctly. Failure to do so could result in personal injury or equipment damage. This manual and safety signs on your machine may also be available in other languages. (See your John Deere dealer to order.)

THIS MANUAL SHOULD BE CONSIDERED a permanent part of your machine and should remain with the machine when you sell it.

MEASUREMENTS in this manual are given in both metric and customary U.S. unit equivalents. Use only correct replacement parts and fasteners. Metric and inch fasteners may require a specific metric or inch wrench.

RIGHT-HAND AND LEFT-HAND sides are determined by facing in the direction the implement will travel when going forward.

WRITE PRODUCT IDENTIFICATION NUMBERS (P.I.N.) in the Specification section. Accurately record

all the numbers to help in tracing the machine should it be stolen. Your dealer also needs these numbers when you order parts. File the identification numbers in a secure place off the machine.

WARRANTY is provided as part of John Deere's support program for customers who operate and maintain their equipment as described in this manual. The warranty is explained on the warranty certificate which you should have received from your dealer.

This warranty provides you the assurance that John Deere will back its products where defects appear within the warranty period. In some circumstances, John Deere also provides field improvements, often without charge to the customer, even if the product is out of warranty. Should the equipment be abused, or modified to change its performance beyond the original factory specifications, the warranty will become void and field improvements may be denied. Setting fuel delivery above specifications or otherwise overpowering machines will result in such action.

Checklists

DEALER'S RECORD

Owner's Name _____ Date Sold _____
Address _____ Model Number _____
City _____ Serial Number _____
State _____ Zip _____

EX,435USU,A -19-25JAN91

PREDELIVERY

After surface wrap has been completely assembled, inspect it to be sure it is in good running condition before delivering to the customer. The following checklist is a reminder of important points to inspect. Check off each item as it is found satisfactory or after proper adjustment has been made.

- Surface wrap has been assembled properly.
- Check clearance between ends of belt guide straps and the bottom crossmember. There must be 2 to 4 mm (3/32 to 5/32 in.) clearance. (Refer to Servicing Lower Front Gate Roll in the Service section.)
- Surface wrap has been lubricated.
- Check all hydraulic hoses and connections for oil leaks.
- Check operating functions of surface wrap. (Refer to Operating Surface Wrap System with Empty Baler in the Operating Baler with Surface Wrap section.)
- Check belt tracking. (See Checking Belt Tracking in the Service section of the baler operator's manual.)
- Decals intact and legible.

(Date set up)

(Signature)

EX,435USU,BA1 -19-25SEP95

Checklists

DELIVERY

The following checklist is a reminder of very important information which should be conveyed to the customer at the time the surface wrap is delivered. Check off each item as it is fully explained to the customer.

- John Deere warranty.
- Safe and correct operation and service.
- Correct lubricants.
- Daily and periodic inspections.
- Servicing machine regularly and correctly.
- Advise customer of safety precautions that must be observed while operating surface wrap.
- Storing machine correctly.
- John Deere parts and service.
- Give the operator's manual to the customer and explain all operating adjustments and lubrication fully. Encourage customer to read manual.
- Have customer record machine serial number in the Specifications section of the operator's manual.
- Remove and file this page.

(Date Delivered)

(Signature)

EX,435USU,CA1 -19-25SEP95

Checklists

AFTER-SALE

It is suggested the following items be checked sometime during the first season of operation.

- Go over entire machine for loose or missing hardware.
- Check for broken or damaged parts.
- Check operating adjustments.

- If possible, run baler to see if surface wrap is functioning properly. Inspect wraps on a few bales.
- Review the entire operator's manual with the customer and stress the importance of proper and regular lubrication and safety precautions.

(Date Checked)

(Signature)

EX,435USU,DA1 -19-25SEP95

Checklists

Contents

	Page		Page
Safety	1	Service	
Preparing Baler for Surface Wrap		Practice Safety	31
Selecting Surface Wrap Material	6	Adjusting Feed Roll Pressure	31
Care of Surface Wrap Material	6	Checking Drive Belt Length	32
Additional Surface Wrap Storage	6	Removing and Installing Belt	33
Opening and Closing Surface Wrap		Removing V-Belt Idler Arms	34
Cover	7	Removing and Installing Knife	34
Threading Surface Wrap and Routing		Checking Brake	35
Through Rolls	7	Adjusting Microswitch	36
Operating Baler with Surface Wrap		Removing Wrappage From Feed Rollers	36
General Information	10	Adjusting Roll Support Brackets	38
How the Surface Wrap Attachment Works	10	Adjusting Knife Arm Stop	39
Using Surface Wrap after Extended		Increasing Brake Bar Tension	41
Storage	11	Decreasing Brake Bar Tension	42
BALE-TRAK Monitor Operation with		Servicing Lower Front Gate Roll	43
Surface Wrap	13	Bleeding Hydraulic Circuit	44
Discharging Bale with Surface Wrap	13	Surface Wrap Hydraulic System	45
Changing From Twine Wrap to Surface		Surface Wrap Assembly	46
Wrap	14	Specifications	
Adjusting Number of Surface Wraps on		Record Product Identification Number	73
the Baler	15	Bolt and Cap Screw Torque Value Charts	
Changing from Surface Wrap to Twine		Metric	74
Wrap	16	Inch	75
Operating Surface Wrap System With		Index	
Empty Baler	17		
Releasing Knife Arm Manually	18		
Lubrication and Maintenance			
Grease	19		
Alternative Lubricants	19		
Observe Lubrication Symbols	19		
Perform Lubrication and Maintenance	20		
Lubrication and Maintenance			
Every 30 Hours	20		
Annually	21		
Troubleshooting	22		

All information, illustrations and specifications in this manual are based on the latest information available at the time of publication. The right is reserved to make changes at any time without notice.

OME87620 K5-19-30OCT95

COPYRIGHT© 1995
DEERE & COMPANY
Moline, Illinois
All rights reserved
A John Deere ILLUSTRATION® Manual
Previous Editions
Copyright 1992, 1991 Deere & Company

Contents

Safety

RECOGNIZE SAFETY INFORMATION

This is the safety-alert symbol. When you see this symbol on your machine or in this manual, be alert to the potential for personal injury.

Follow recommended precautions and safe operating practices.

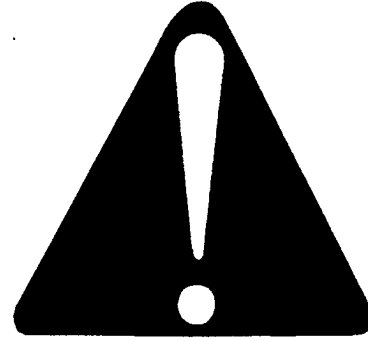

DX,ALERT -19-03MAR93

T81389 -UN-07DEC88

UNDERSTAND SIGNAL WORDS

A signal word—DANGER, WARNING, or CAUTION—is used with the safety-alert symbol. DANGER identifies the most serious hazards.

DANGER or WARNING safety signs are located near specific hazards. General precautions are listed on CAUTION safety signs. CAUTION also calls attention to safety messages in this manual.



DX,SIGNAL -19-03MAR93

TS187 -19-30SEP88

FOLLOW SAFETY INSTRUCTIONS

Carefully read all safety messages in this manual and on your machine safety signs. Keep safety signs in good condition. Replace missing or damaged safety signs. Be sure new equipment components and repair parts include the current safety signs. Replacement safety signs are available from your John Deere dealer.

Learn how to operate the machine and how to use controls properly. Do not let anyone operate without instruction.

Keep your machine in proper working condition. Unauthorized modifications to the machine may impair the function and/or safety and affect machine life.

If you do not understand any part of this manual and need assistance, contact your John Deere dealer.



DX,READ -19-03MAR93

TS201 -UN-23AUG88



REMOVE PAINT BEFORE WELDING OR HEATING

Avoid potentially toxic fumes and dust.

Hazardous fumes can be generated when paint is heated by welding, soldering, or using a torch.

Do all work outside or in a well ventilated area. Dispose of paint and solvent properly.

Remove paint before welding or heating:

- If you sand or grind paint, avoid breathing the dust. Wear an approved respirator.
- If you use solvent or paint stripper, remove stripper with soap and water before welding. Remove solvent or paint stripper containers and other flammable material from area. Allow fumes to disperse at least 15 minutes before welding or heating.



TS220 -UN-23AUG88

DX,PAINT -19-03MAR93

AVOID HEATING NEAR PRESSURIZED FLUID LINES

Flammable spray can be generated by heating near pressurized fluid lines, resulting in severe burns to yourself and bystanders. Do not heat by welding, soldering, or using a torch near pressurized fluid lines or other flammable materials. Pressurized lines can be accidentally cut when heat goes beyond the immediate flame area.



TS953 -UN-15MAY90

DX,TORCH -19-03MAR93



AVOID HIGH-PRESSURE FLUIDS

Escaping fluid under pressure can penetrate the skin causing serious injury.

Avoid the hazard by relieving pressure before disconnecting hydraulic or other lines. Tighten all connections before applying pressure.

Search for leaks with a piece of cardboard. Protect hands and body from high pressure fluids.

If an accident occurs, see a doctor immediately. Any fluid injected into the skin must be surgically removed within a few hours or gangrene may result. Doctors unfamiliar with this type of injury should reference a knowledgeable medical source. Such information is available from Deere & Company Medical Department in Moline, Illinois, U.S.A.

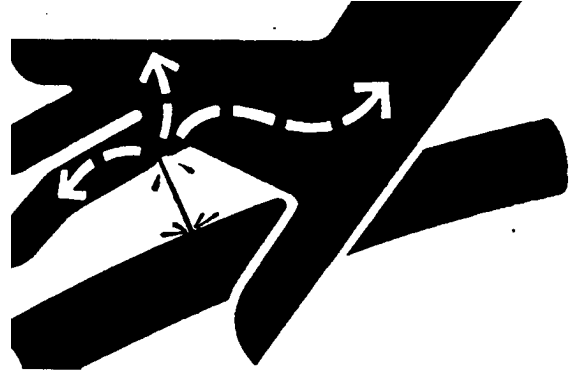

-JUN-23AUG88

X9811

DX,FLUID -19-03MAR93

DISPOSE OF WASTE PROPERLY

Improperly disposing of waste can threaten the environment and ecology. Potentially harmful waste used with John Deere equipment include such items as oil, fuel, coolant, brake fluid, filters, and batteries.

Use leakproof containers when draining fluids. Do not use food or beverage containers that may mislead someone into drinking from them.

Do not pour waste onto the ground, down a drain, or into any water source.

Air conditioning refrigerants escaping into the air can damage the Earth's atmosphere. Government regulations may require a certified air conditioning service center to recover and recycle used air conditioning refrigerants.

Inquire on the proper way to recycle or dispose of waste from your local environmental or recycling center, or from your John Deere dealer.

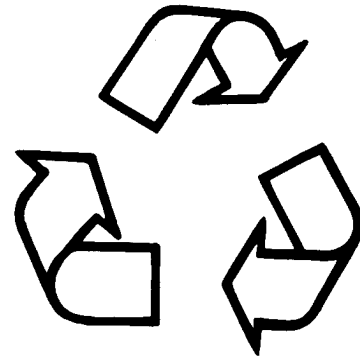

-JUN-26NOV90

TS1133

DX,DRAIN -19-03MAR93



SAFETY SIGNS

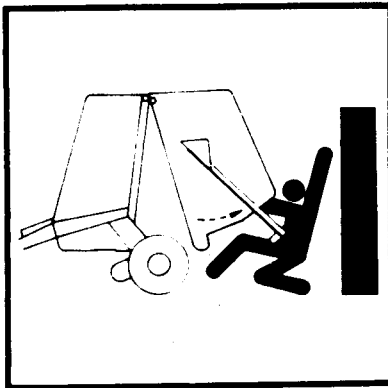

⚠ WARNING

HELP PREVENT CRUSHING INJURY:
Be sure bystanders stand clear before
operating gate and unloading bale.

STAY CLEAR OF GATE AND/OR PUSH BAR
while being raised or lowered.
WATCH FOR ROLLING BALE.

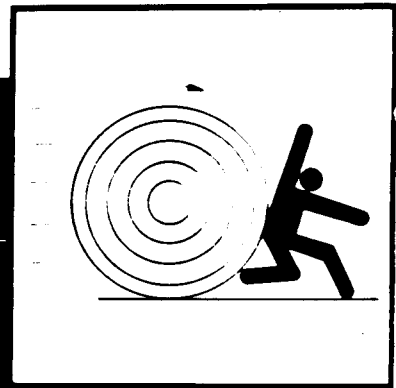

E35380 -19-21AUG90

EX,435USC,AA1 -19-25SEP95

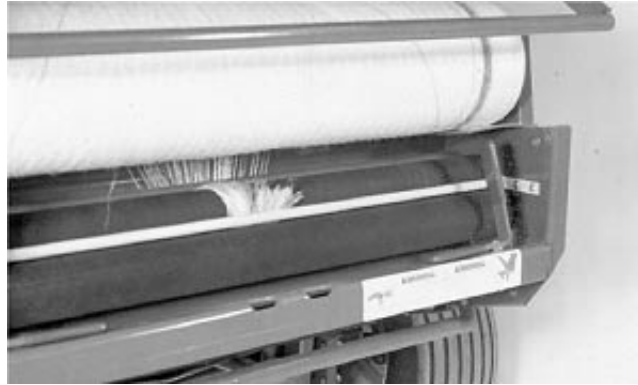

E35388 -UN-28AUG90

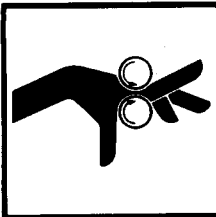

⚠ WARNING

Avoid injury from entanglement in moving rolls. Disengage drive and shut off engine before servicing.

⚠ WARNING

KNIFE IS EXTREMELY SHARP AND CAN MOVE WITHOUT WARNING. Shut off machine before servicing knife. Keep hands clear of sharp edge.



E35529 -19-26SEP90

EX,435USC,B -19-25SEP90

Preparing Baler for Surface Wrap

SELECTING SURFACE WRAP MATERIAL

In order to achieve optimum performance, we recommend the use of high-quality surface wrap. Use only John Deere approved surface wrap material. Approved material is identified by a green strip near each end of the roll. (See your John Deere dealer.)

For the 435 Round Baler use a roll size of 3000 m (9842 ft). The roll can make approximately 250 bales of 1.8 m (6 ft) diameter with 2 turns of surface wrap.

For the 535 Round Baler use a roll size of 2000 m (6562 ft). The roll can make approximately 165 bales of 1.8 m (6 ft) diameter with 2 turns of surface wrap.

EX,435USI,A -19-24JUN92

CARE OF SURFACE WRAP MATERIAL

Protect surface wrap material from moisture and damage.

Snags can cause erratic performance and affect bale appearance and weatherability.

Store in a cool, dry place, away from direct sunlight.

Do not remove protective covering until ready for use.

EX,435USI,B -19-25JUN90

ADDITIONAL SURFACE WRAP STORAGE

Brackets can be used to carry a spare roll of surface wrap material. Brackets are available through Service Parts.

EX,435USI,C -19-25JUN90

OPENING AND CLOSING SURFACE WRAP COVER

⚠ CAUTION: Be sure PTO is disengaged and tractor engine is shut off before opening cover.

⚠ CAUTION: Cover is spring loaded and will move up quickly when released.

1. Pull rearward on handle (A) and raise cover.
2. To close, pull cover down and push shut.

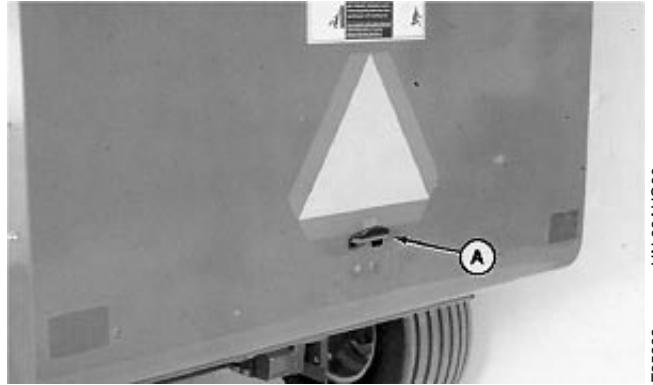

E35383 -UN-28AUG90

EX,435USI,D -19-23AUG90

THREADING SURFACE WRAP AND ROUTING THROUGH ROLLS

1. Open surface wrap cover.
2. Rotate brackets (A) outward to hold surface wrap roll.
3. Rotate knife arm back to disengage feed roll brake. (See Releasing Knife Arm Manually in Operating Baler with Surface Wrap section.)

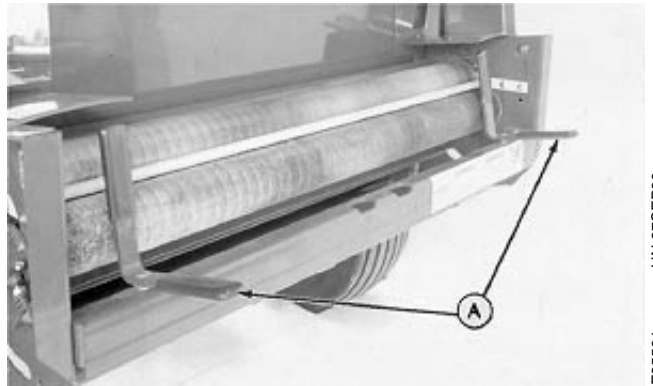

E35501 -UN-27SEP90

EX,435USI,FA1 -19-25SEP95

Preparing Baler for Surface Wrap

4. Remove ALL packaging material (staples, tapes, etc.) from surface wrap roll before installing.

5. Lay surface wrap roll on brackets so material will be pulled from the top of the roll (illustrated).



E35398
-UN-27SEP90

EX,435USI,G -19-27SEP90

6. Gather the loose end of surface wrap together and pull from the top of the roll and over center of steel roller (A).

7. Wrap material around steel roll. Feed material up between steel and rubber rolls by rotating rubber rolls. Pull loose end rearward to remove slack.



E34254
-UN-24JUL90

EX,435USI,H -19-27SEP90

Preparing Baler for Surface Wrap

8. Lift surface wrap roll from loading brackets onto support brackets. (Roll can be lifted one end at a time.)

9. Rotate loading brackets (A) inward.

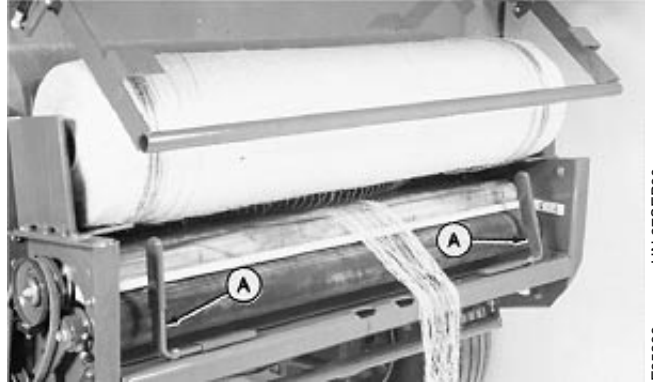

E35399
-UN-27SEP90

EX,435USI,I -19-11OCT90

10. Fold surface wrap material back on itself to form a loop.

11. Thread loop of surface wrap between yellow rod and top rubber roll. Rotate rolls slightly to feed wrap material between rubber rolls .

IMPORTANT: Do not thread more than 25 mm (1 in.) of loop between the two rolls or it may cause material to wrap around the rolls.

NOTE: If surface wrap is not being pulled off the front face of roll, the roll has been installed backward. (Refer to step 1 for correct installation.)



E94257
-UN-24JUL90

EX,435USI,J -19-24JAN91

IMPORTANT: Avoid knife contact with rubber rolls. Any knife cuts in the rubber roll covering may result in more frequent wrapping around the rollers and may require roller replacement.

12. Cut off loose end of surface wrap as illustrated.

13. Rotate knife arm forward to engage brake.

14. Close surface wrap cover.



E94258
-UN-24JUL90

EX,435USI,K -19-27SEP90

Operating Baler with Surface Wrap

GENERAL INFORMATION

The baler can operate with either surface wrap or twine wrap.

When operating the twine wrap system, refer to Preparing the Baler section in the baler operator's manual for proper preparation.

Instructions regarding the operation of the surface wrap system and changing from one wrapping mode to the other are found in this section of the manual.

When using surface wrap after an extended storage, refer to Using Surface after Extended Storage in this section to minimize start-up problems.

EX,435USJ,A -19-24JUN92

HOW THE SURFACE WRAP ATTACHMENT WORKS

While the bale is being formed, the surface wrap system is idle. The surface wrap mechanism is automatically tripped in the same manner as the conventional twine wrap system.

When the baler is in the surface wrap mode, both twine and surface wrap mechanisms operate simultaneously. Although twine arms move when surface wrap is being applied, twine will not be applied to bale because twines are not threaded out the end of the tubes.

When the wrap cycle begins, oil from the pump flows to extend the twine arm cylinder (moving the twine arm toward the right-hand side of the baler) and to the top surface wrap cylinder which moves the knife arm back and engages the V-belt which drives the rubber feed rolls.

While twine arms are moving from left to right, the surface wrap is fed from the surface wrap roll through

the rubber feed rolls, along the baler belts underneath the gate, and then is caught by the bale and wrapped around it. The number of mesh wraps applied to the bale is determined by the amount of time required for twine arm to travel from left to right.

When the twine arms reverse the valve, oil is directed to retract the twine cylinder (returning twine arm to home position) and to extend the lower surface wrap cylinder which moves the knife arm forward, disengaging the V-belt, stopping the rubber feed rollers with a brake, and cutting off the surface wrap.

As the surface wrap is cut off, the knife pushes the surface wrap forward. The surface wrap contacts a lever releasing a microswitch. The switch activates an alarm and lights the red light. After the surface wrap is cut off, the lever and switch return to their original position, and the light and alarm are shut off. The entire cutoff process takes approximately 1 second.

EX,435USJ,B -19-06FEB91

USING SURFACE WRAP AFTER EXTENDED STORAGE

To minimize start-up problems after storage:

1. Remove excessive dust from feed rolls (A) with a dry cloth.

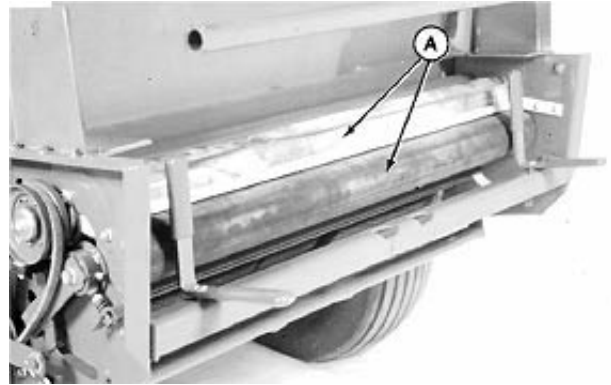

EX,435USP,Y -19-24JUN92

E36890 -UN-25JUN92

2. Lower pan and guide assembly (A). Polish area (B) until smooth with SCOTCH-BRITE® or ultra-fine sandpaper. When using sandpaper, polish marks must be parallel to movement of mesh.

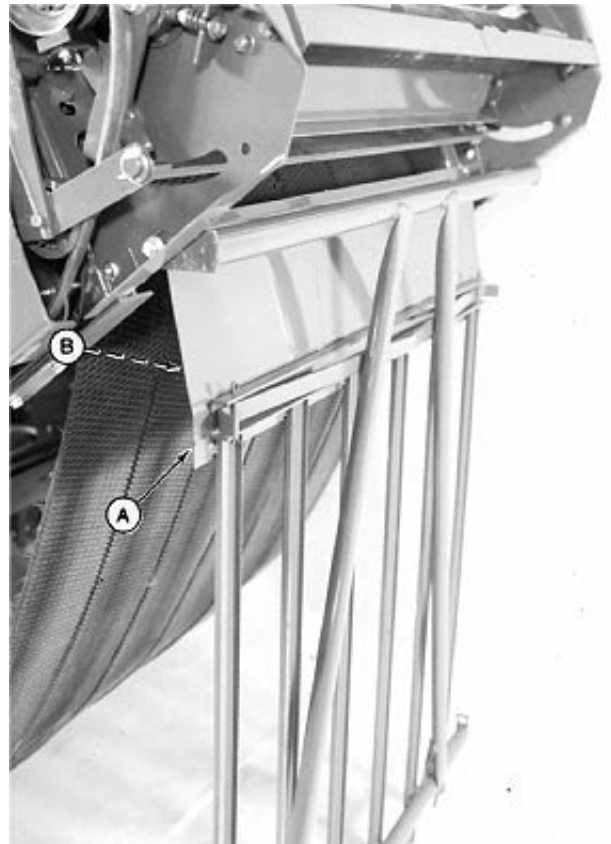

SCOTCH-BRITE is a trademark of the 3M Company.

EX,435USP,Z -19-06OCT95

E36891 -UN-25JUN92

3. Remove rust from surface wrap brake (A), using SCOTCH-BRITE or ultra-fine sandpaper.

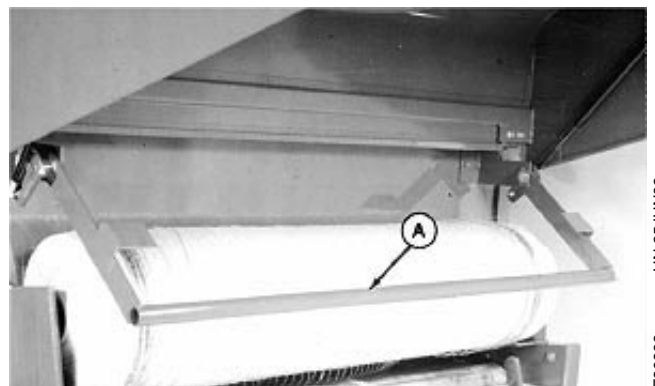

EX,435USP,AA -19-24JUN92

E36892 -UN-25JUN92

4. Clean guides (A) with dry cloth.

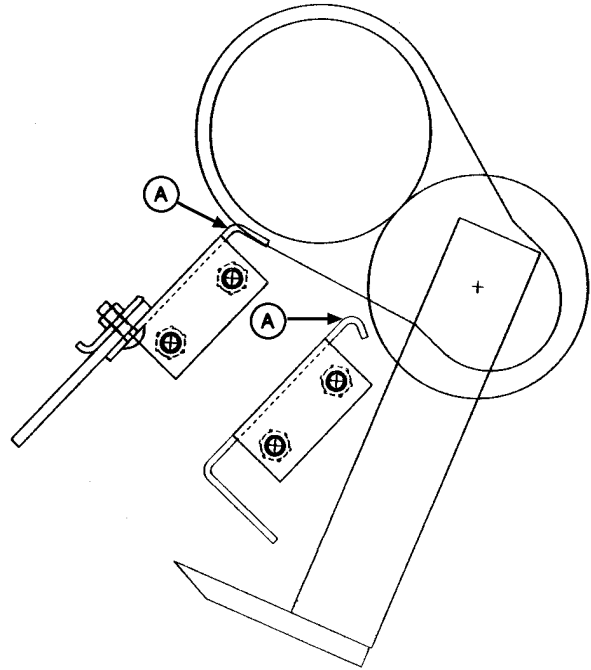

EX,435USP,AC -19-06OCT95

E39531 -JUN-06OCT95

BALE-TRAK® MONITOR OPERATION WITH SURFACE WRAP



The basic function of the monitor is very similar, whether using twine wrap or surface wrap. The function of the green light (gate closed and latched), bale shape gauges, flashing yellow light (bale near full), and solid yellow light (twine arm moving) are the same.

When either wrapping system starts, a short alarm sounds and the flashing yellow light changes to solid yellow. When baling with surface wrap, stop forward travel immediately to ensure surface wrap is on the outside of the bale and will not be partially covered by loose incoming material.

A second alarm will sound and the red light will flash a few seconds after the first alarm. The green light will stay on with this signal.

This indicates the surface wrap has fed onto the bale and has cut off properly. The bale may be ejected immediately.

If the second alarm does not sound there is no wrap on the bale. The surface wrap roll may be empty or surface wrap may have misfed. Investigate cause and wrap bale properly prior to ejection of the bale. (See Troubleshooting section.)

If second alarm and red light stay on (with green light on), surface wrap is not cut off properly. Investigate prior to ejection of the bale. (See Troubleshooting section.)

The red light and alarm (without green light) indicate an oversize bale.

EX,435USJ,CA1 -19-25SEP95

DISCHARGING BALE WITH SURFACE WRAP

If ejecting with PTO running, the bale can be ejected anytime after the cutoff alarm stops.

If PTO is shut off before ejecting the bale, wait until the twine arms return home (yellow light goes out) before disengaging PTO.

EX,435USJ,D -19-06FEB91

CHANGING FROM TWINE WRAP TO SURFACE WRAP

NOTE: If baler has been used for twine wrapping:

- Pull twine back into twine tubes
- Tie off ends of twine through holes in twine arm channels as shown.

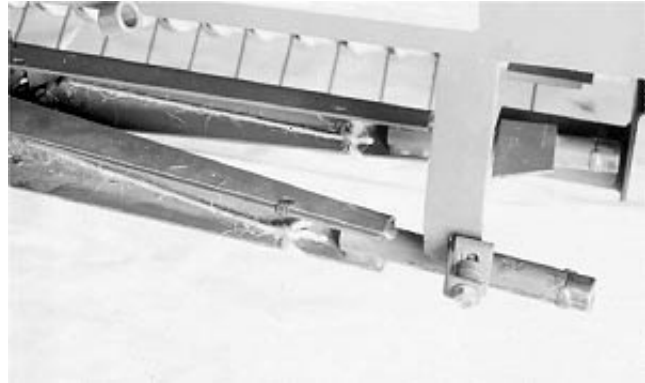

EX,435USJ,E -19-17JAN91

E32676 -UN-29NOV88

1. Turn on-off valve (A) fully open (counterclockwise) to activate the surface wrap mechanism.

NOTE: If baler has previously been operated with surface wrap, adjustment of control knob (C) is not required.

2. For initial setting of surface wrap turns, loosen locking ring (B) and turn flow control knob (C) fully counterclockwise. Turn flow control knob (C) one turn back in clockwise direction and tighten locking ring.

NOTE: If baler has been set properly for twine wrapping, note the number of turns required to fully open valve (D). This enables easy return to the same twine space setting when changing back to twine wrapping.

3. Loosen locking ring (E) and fully turn control knob (D) counterclockwise. Tighten locking ring.

4. For final adjustment see Adjusting Number of Surface Wraps On The Bale, this section.

5. Remove surface wrap material from between feed rolls and rethread. (See Threading Surface Wrap and Routing Through Rolls in Preparing Baler for Surface Wrap section.)

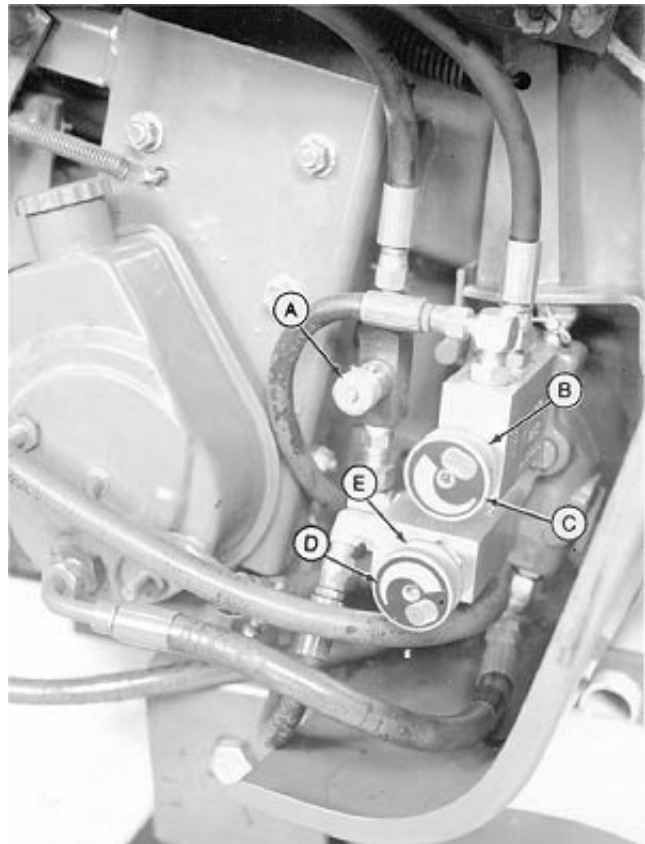

- A—On-Off Valve
- B—Locking Ring
- C—Surface Wrap Flow Control Knob
- D—Twine Flow Control Knob
- E—Locking Ring

EX,435USJ,FA1 -19-25SEP95

E34259 -JUN-24JUL90

ADJUSTING NUMBER OF SURFACE WRAPS ON THE BALE

1. For initial setting of surface wraps, loosen locking ring (A) and turn flow control knob (B) fully counterclockwise. Turn flow control knob (B) back one turn in clockwise direction and tighten locking ring (A).

To improve the initial setting:

- Raise the gate fully. Lock gate in the up position.
- Engage tractor PTO to cycle twine arms.
- Pull and release trip rope to recycle the twine arms.
- Adjust top flow control knob until it takes 5 to 6 seconds for twine arms to travel from left side of baler to right side to trip the linkage and reverse direction.

NOTE: If the on-off valve for surface wrap is on when twine arms are traveling from left to right, the surface wrap knife arm should move to the rear. When twine arms are traveling from right to left, the surface wrap knife arm should move forward.

2. To increase number of wraps, loosen locking ring (A) and turn flow control knob (B) clockwise approximately 1/8 turn at a time until desired number of wraps is obtained.

3. To decrease number of wraps, loosen locking ring (A) and turn flow control knob (B) counterclockwise approximately 1/8 turn at a time until desired number of wraps is obtained.

NOTE: Number of wraps may change slightly as the oil warms up. It is recommended to make a few bales before making final wrap adjustment.

It is recommended to use two complete wraps for normal baling conditions. More wraps may be required in some crop conditions such as cornstalks, straw, or silage.

If bale size has been changed, it may be necessary to adjust the flow valve setting to compensate for the size change.

PTO speed must be kept constant during the wrapping cycle and from one bale to the next in order for the number of wraps to be consistent.

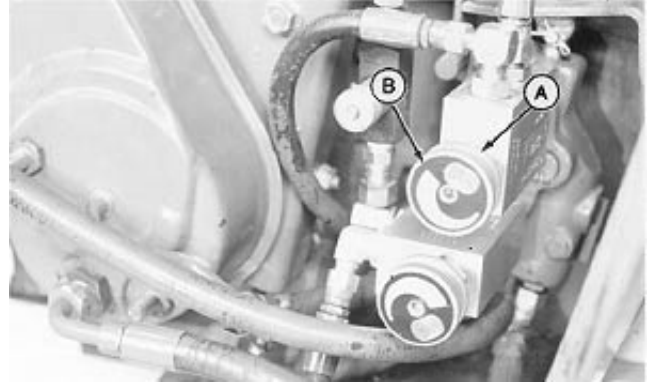

E34260 -UN-24JUL90

CHANGING FROM SURFACE WRAP TO TWINE WRAP

1. Route twine if needed. (See Routing Twine From Right-Hand and Left-Hand Twine Boxes in Preparing the Baler section in the baler operator's manual.)

If previously threaded, untie ends of twine from twine arms and thread twine through twine tubes leaving approximately 305 mm (12 in.) of twine beyond end of tubes.

2. Turn knob on valve (A) fully clockwise to shut-off position.

3. Make initial adjustment of twine spacing by loosening locking ring (E) and turning flow control knob (D) fully counterclockwise, then turn back clockwise 1-1/4 turns and tighten locking ring (E).

4. Final twine spacing adjustment can be made when the oil in the system is warm. (See Adjusting Twine Spacing in Preparing the Baler section in the baler operator's manual.)

NOTE: When making the final adjustment, turn knob approximately 1/8 of a turn each time. If knob is turned too far clockwise, twine arm will move to the right but will not move to the left.

NOTE: Do not adjust surface wrap flow valve (C) when changing from surface wrap to twine. Once adjusted, valve (C) can be left in that position indefinitely.

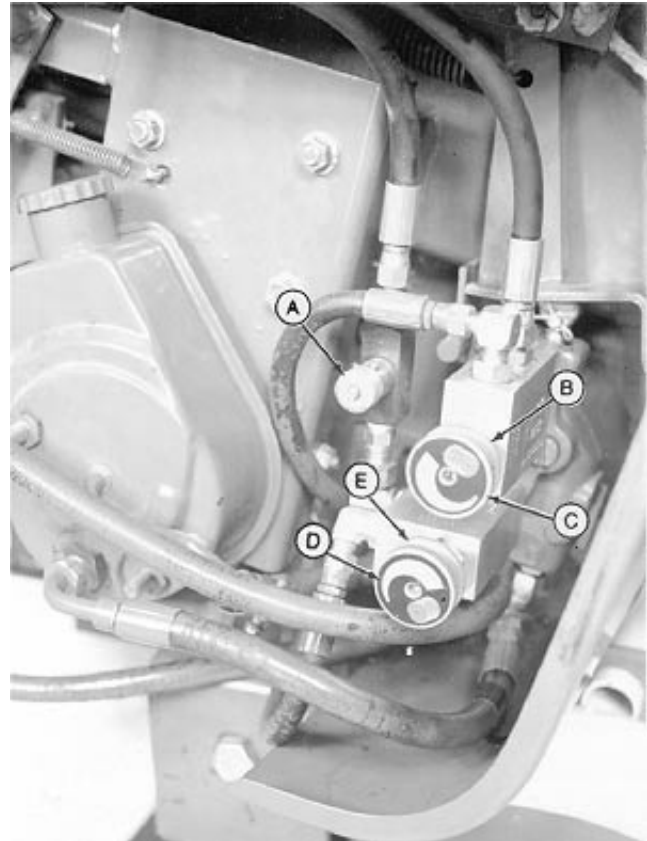

A—On-Off Valve
B—Locking Ring
C—Surface Wrap Control Knob
D—Twine Flow Control Knob
E—Locking Ring

E34259 -UN-24JUL90

EX,435USJ,H -19-24JAN91

OPERATING SURFACE WRAP SYSTEM WITH EMPTY BALER

IMPORTANT: Do not operate more than one minute in this mode or bale forming belts may be damaged.

NOTE: Surface wrapping is a fast process. When adjusted for normal operation, it takes only 5 to 10 seconds for a complete cycle. It may be helpful to slow the process down by turning both flow control knobs (A) clockwise approximately 1 turn each, to allow more time for observation.

Be sure flow valves are returned to original setting before making the next bale.

To observe knife operation and V-belt idler:

1. Lock gate in closed position with gate lock valve.
2. Raise tension arm fully.
3. Open surface wrap cover to observe movement of knife arm and V-belt idler.



CAUTION: Stay clear of moving parts. Knife will return automatically without warning.

4. Engage PTO.
5. Pull rope to recycle the system if necessary.

Twine arms and surface wrap will cycle. However, bale forming belts will not turn and V-belt drive does not rotate.

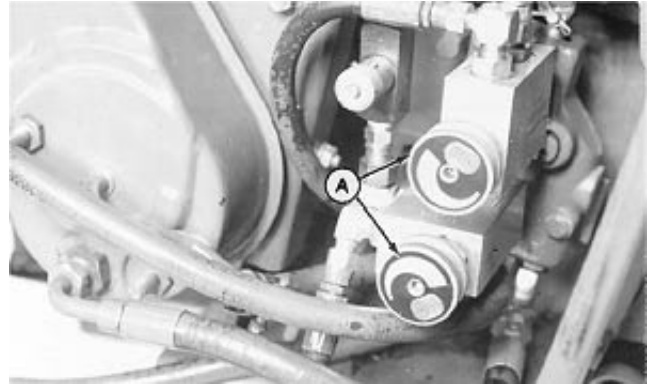

E34261 -UN-24JUL90

EX,435USJ,IA1 -19-27OCT95

RELEASING KNIFE ARM MANUALLY

If it is necessary to manually rotate the surface wrap feed rolls, service the knife, or check V-Belt length:

1. Disengage PTO and shut off tractor engine.
2. Open right-hand shield door to access the hydraulic valves.

NOTE: On-off valve (A) must be opened fully (counterclockwise). The spool in the shifter valve (B) must be in the raised position to release the hydraulic oil which holds the knife arm forward.

If baler tension arm is up, pull the trip rope and release to lift the spool. If the tension arm is not high enough to raise the spool fully when trip rope is actuated, lift the spool manually by placing fingers on either side of spool (illustrated) and pulling upward for 1 to 2 seconds.

3. With cover of the surface wrap unit open, swing the knife arm back until the brake is clear of the sheave. The rolls should be free to rotate.

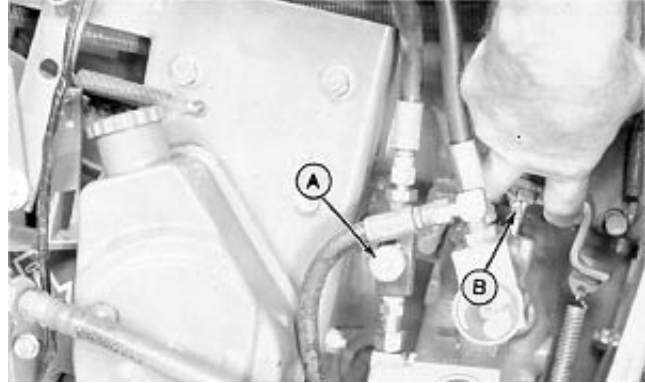

-UN-24JUL90
E34262

EX,435USJ,J -19-14SEP90

Lubrication and Maintenance

GREASE

Use grease based on the expected air temperature range during the service interval.

The following greases are preferred:

- John Deere MOLY HIGH TEMPERATURE EP GREASE
- John Deere HIGH TEMPERATURE EP GREASE
- John Deere GREASE-GARD™

Other greases may be used if they meet one of the following:

- SAE Multipurpose EP Grease with a maximum of 5% molybdenum disulfide
- SAE Multipurpose EP Grease

Greases meeting Military Specification MIL-G-10924F may be used as arctic grease.

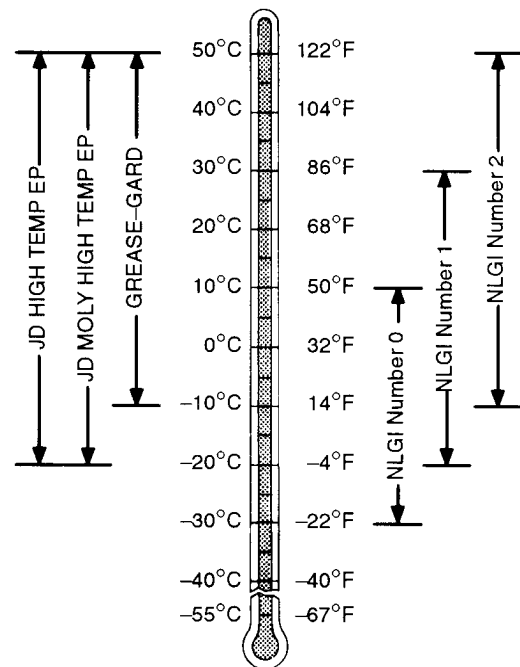

DX,GREA1 -19-02NOV94

TS1622 -UN-02NOV94

ALTERNATIVE AND SYNTHETIC LUBRICANTS

Conditions in certain geographical areas may require lubricant recommendations different from those printed in this manual. Some John Deere lubricants may not be available in your location. Consult your John Deere dealer to obtain information and recommendations.

Synthetic lubricants may be used if they meet the performance requirements listed in this manual.

DX,ALTER -19-01FEB94

OBSERVE LUBRICATION SYMBOLS



Lubricate with John Deere EP Moly or an equivalent SAE multipurpose-type grease (unless otherwise specified) at hourly intervals indicated.



Lubricate with SAE 30 or heavier oil at hourly intervals indicated.

EX,435USN,A1 -19-25SEP95

PERFORM LUBRICATION AND MAINTENANCE

CAUTION: Do not clean, lubricate, or adjust your machine while it is in motion.

IMPORTANT: The period recommended is based on normal conditions; severe or unusual conditions may require more frequent lubrication or oil changes.

Perform each lubrication and service illustrated in this section at the beginning of the season and at the end of the season.

Clean grease fittings before using grease gun. Replace any lost or broken fittings immediately. If a new fitting fails to take grease, remove and check for failure of adjoining parts.

EX,700TRN,A2 -19-05JUN95

EVERY 30 HOURS

IMPORTANT: Do not over lubricate knife arm pivot grease fittings as this will result in grease getting onto the rubber rolls causing wrappage.

-  A—Knife Arm Pivot (Right Side)
-  B—Idler Arm Pivot (Left Side)
-  C—Knife Arm Pivot (Left Side)



-UN-24,JUL90
E34263

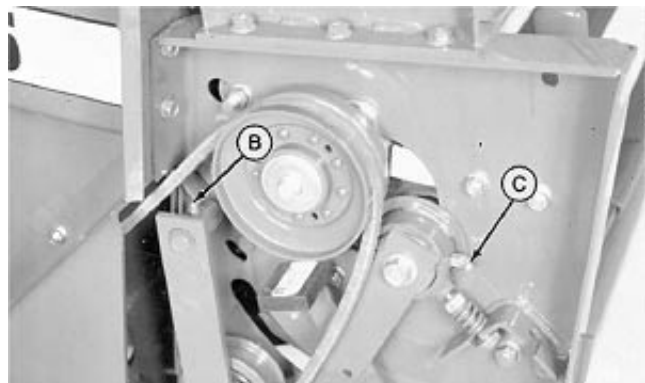

-UN-24,JUL90
E34264

EX,435USN,A -19-16JAN91

ANNUALLY



A—Cylinder Pins

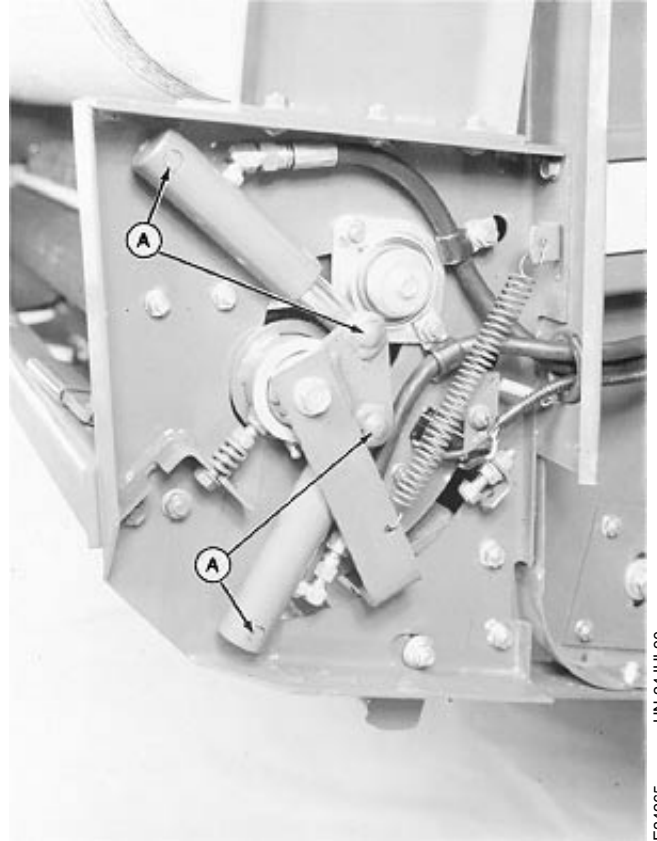

E34265 -UN-24JUL90

EX,435USN,B -19-23AUG90

Troubleshooting

Symptom	Problem	Solution
Bale not wrapped (no cutoff signal).	On-off valve shut off.	Open valve fully. (See Changing from Twine Wrap to Surface Wrap in Operating Baler with Surface Wrap section.)
	Wrap material incorrectly threaded around yellow bar.	Thread between top rubber roll and yellow bar. (See Threading Surface Wrap and Routing Through Rolls in Preparing Baler for Surface Wrap.)
	Surface wrap supply roll empty.	Install new roll. (See Threading Surface Wrap and Routing Through Rolls in Preparing Baler for Surface Wrap section.)
	Surface wrap material wrapped around rubber feed rolls.	Remove material from rollers. (See Surface Wrap Material Wrapped Around Rubber Feed Rolls in this section.)
	Surface wrap material not started between rubber feed rolls.	Route surface wrap correctly. (See Threading Surface Wrap and Routing Through Rolls in Preparing Baler for Surface Wrap section.)
	Roll of surface wrap material installed in unit backwards.	Install roll correctly. (See Threading Surface Wrap and Routing Through Rolls in Preparing Baler for Surface Wrap section.)
	Surface wrap feed roll drive not engaged.	Check for broken, worn, or too long V-belt. (See Checking Drive Idler Adjustment in Service section.)
		Check for binding at knife arm pivots and V-belt idler pivot.
	Twine arm did not cycle normally.	See Automatic Twine Wrap in Troubleshooting section of the baler operator's manual.
	Broken or weak spring on V-belt idler.	Replace spring.
Feed roll pressure set too low.	Adjust feed roll pressure. (See Adjusting Feed Roll Pressure in Service section.)	
Roll of surface wrap material larger than 305 mm (12 in.).	Use correct size roll of surface wrap. (See your John Deere dealer.)	
Gas springs installed in wrong hole on brake arm.	Install gas springs in hole closest to brake pivot. (See Decreasing Brake Bar Tension in Service section.)	

Continued on next page

Troubleshooting

Symptom	Problem	Solution
<p>Surface wrap material wrapped around rubber feed rolls.</p> <p>IMPORTANT: Do not cut surface wrap material from rubber feed rolls. Any knife cuts in the rubber roll covering may result in more frequent wrapping around the rollers and may require roller replacement. (See Removing Wrappage from Feed Rollers in Service section.)</p>	Static electricity or dampness causing surface wrap material to cling to the rolls.	Dust the rubber drive rolls with talcum powder such as A51237, available from your John Deere dealer.
	Dirt, rust, or roughness on pan surface.	Polish upper pan surface with SCOTCH-BRITE® or ultra fine sandpaper. Polish marks must be parallel to movement of mesh. (Refer to Using Surface Wrap after Extended Storage in Operating the Baler section.)
	Knife arm stop bolt not adjusted correctly.	Adjust. If knife is set too close to rubber flap, it may cause roll wrappage. (See Adjusting Knife Arm Stop in Service section.)
	Knife not holding the surface wrap.	See Adjusting Knife Arm Stop in Service section.
	Feed roll pressure set too high.	Adjust feed roll pressure. (See Adjusting Feed Roll Pressure in Service section.)
	Surface wrap roll continues to turn after cutoff.	Increase brake bar tension. (See Increasing Brake Bar Tension in the Service section.)
	Dust and/or moisture on surface of rubber rolls causing mesh to stick to rolls.	Be sure tape across cover hinge joint at the top of the cover is intact. Replace if necessary.
		Dry rolls off if dew is present. Thread mesh.
	Rubber roll damaged or sticky.	Clean by wiping with clean rag or soap and water. NEVER use solvents. Replace roller if damaged.
	V-Belt idler out of adjustment.	Adjust idler. (See Checking Drive Idler Adjustment in Service section.)
	Knife installed on top of knife arms or with bevel up, or bolts through knife upside down.	Position knife and attaching bolts correctly. (See Removing and Installing Knife in Service section.)
	Roller scraper/guide damaged.	Replace. See your John Deere dealer.

Troubleshooting

Symptom	Problem	Solution
	Surface wrap material sticky from adhesive used in packaging (tape, etc.).	Remove any sticky material from the supply roll by unrolling, cutting and discarding.
	Surface wrap material improperly routed, or too much of the end loop started through feed rolls when threading.	Route and thread surface wrap correctly. (See Threading Surface Wrap and Routing Through Rolls in Preparing Baler for Surface Wrap section.)
Bale not wrapped (cutoff signal does activate).	Surface wrap fed to other areas of the machine:	Locate and remove surface wrap material before making the next bale. Otherwise, improper belt tracking and further incorrect feeding may result if material is not removed promptly and the cause is not corrected.
	a) Starter roll wrappage.	Remove all burrs, weld splatters, rough spots, and imperfections on starter roll. Mud or sticky crop residue can cause occasional starter roll wrappage.
	b) Baler drive roll wrappage.	Do not damage rubber strips when removing surface wrap material.
	c) Upper idler roll wrappage.	In rare occasions, surface wrap material can be found on the upper idler roll. Remove wrappage from upper idler roll to prevent belt tracking problems. Also, see (d) below.
	d) Surface wrap caught in rough belt splices (surface wrap is not transferred from belts to bale during wrapping cycle).	Be sure bent ends of pins are pointing toward smooth side of belt. Inspect and repair broken or damaged belt splices.
	e) Surface wrap bunched behind lower belt guide on gate due to crop buildup.	Remove crop buildup from lower gate area. In some crops, reducing PTO rpm while baling will reduce buildup tendency. Ejecting bale with PTO running will reduce buildup in some conditions. (See Baling Short, Dry, Slick Crops in Operating the Baler section in the baler operator's manual.) Install Build-Up Reduction Scraper Kit.

Continued on next page

Troubleshooting

Symptom	Problem	Solution
Bale not uniformly wrapped (cutoff signal does activate).	Buildup of crop, etc., behind lower belt guide on gate.	Clean out buildup. In some crops, reducing PTO rpm will reduce buildup tendency. Ejecting bale with PTO running will reduce buildup in some conditions. Install Build-Up Reduction Scraper Kit. Available through Service Parts.
	Insufficient number of wraps.	Check to be sure the surface wrap supply roll has not run out. Machine should be set to apply a minimum of two wraps. (Refer to Adjusting Number of Surface Wraps on The Bale in Operating Baler with Surface Wrap section.)
	Belts not tracking properly.	Refer to Adjusting Belt Tracking in Service section in the baler operator's manual.
	Surface wrap cover not closed.	Cover must be closed and latched for best bale coverage.
	Surface wrap supply roll is installed in box backwards.	See Threading Surface Wrap and Routing Through Rolls in Preparing Baler for Surface Wrap section.
	Surface wrap cover gas spring(s) weak.	Check springs on both sides of surface wrap cover. Replace if necessary.
	Roll support brackets damaged or out of adjustment.	See Adjusting Roll Support Brackets in the Service section. Polish surface scratches on stainless steel strips with crocus cloth or ultra fine sandpaper. Polish marks must be parallel to movement of mesh.
	Surface wrap not routed under steel roll.	See Threading Surface Wrap and Routing Through Rolls in Preparing Baler for Surface Wrap section.
	Roll of surface wrap material too narrow.	See your John Deere dealer. Use only approved material for best results.
	Surface wrap partially on bale, partially on feed roll or baler roll.	See "Bale not wrapped (cutoff signal does activate)" in this section.

Continued on next page

Troubleshooting

Symptom	Problem	Solution
	Bale has crop between layers of surface wrap on the bale or loose crop is outside the surface wrap on the bale.	Stop forward travel immediately when the full bale alarm sounds and solid yellow light goes on. Surface wrap begins to feed at that time, and any crop picked up after this will be placed between the layers of surface wrap or outside the wrapping.
Too many wraps of material on bale.	Orifice was not removed from twine arm cylinder when surface wrap bundle was installed.	Remove orifice from twine arm cylinder.
Surface wrap not cut off at end of wrapping cycle.	Dull knife.	Sharpen knife with file. Knife must be very sharp for clean cut-off. (See Removing and Installing Knife in Service section.)
	Brake on front rubber feed roll out of adjustment or worn.	Check and adjust brake. (See Checking Brake in Service section.)
	Knife not returning to cutting position freely.	Check for proper lubrication and binding at knife arm pivots. See your John Deere dealer if binding occurs.
	Surface wrap cover open.	Cover must be closed for best cutoff.
	Twine arm not cycling normally.	See Automatic Twine Wrap in Troubleshooting section in the baler operator's manual.
	Hydraulic lines reversed at surface wrap cylinders or valves.	Refer to Surface Wrapping Hydraulic System in Service section.
	Knife arm stop out of adjustment.	See Adjusting Knife Arm Stop in Service section.
	Defective hydraulic lines to surface wrap unit.	Replace if necessary.
Green light stays on. Red light and alarm come on when gate is opened.	There is a short in orange and green wires.	Unplug orange and green wires. If the alarm stops, there is a short in surface wrap wiring harness. Repair or replace harness.
Alarm, green light, and red light stay on after surface wrap has cut off.	Knife arm stop bolt is out of adjustment (surface wrap is tightly gripped between front of knife and rubber flap after cutoff).	Lengthen stop bolt. (See Adjusting Knife Arm Stop in Service section.)
	Surface wrap microswitch needs adjustment.	Adjust correctly. (See Adjusting Microswitch in Service section.)

Continued on next page

Troubleshooting

Symptom	Problem	Solution
	Return spring on cutoff indicator flap (surface wrap microswitch ramp) is missing or damaged.	Replace spring.
	Knife is dull, causing long strings to keep the cutoff indicator flap and microswitch activated.	Sharpen knife.
	Binding at microswitch lever.	Tighten lock nut and back off 1/4 turn. Check for free movement.
	Binding at cutoff flap.	Check for bent or damaged parts. Repair or replace as necessary.
Brief, intermittent alarm signal when baling or transporting in very rough ground conditions.	Travel speed too high.	Slow down travel speed.
	Cutoff microswitch on surface wrap needs adjustment.	Adjust switch. (See Adjusting Microswitch in Service section.)
	Return spring on cutoff indicator flap (surface wrap microswitch ramp) is damaged or defective.	Replace spring.
Surface wrap loose around bale.	Too many wraps applied.	Normally no more than three wraps are needed. Excess wraps may appear to be loose.
	V-belt idler out of adjustment.	Adjust. (See Checking Drive Idler Adjustment in the Service section.)
	Spring on V-belt drive weak or damaged.	Replace spring.
	Weak gas spring(s).	Check spring(s) for proper force.
	Gas springs installed in wrong hole in brake arm.	Install in correct hole. (See Increasing Brake Bar Tension in Service section.)
Varying number of wraps from one bale to the next.	Dirt in hydraulic system.	Cycle system with both flow valves fully open.
	Twine valve spool not shifting fully.	Remove dirt, rust, or paint from twine valve spool and lubricate.
	Low oil in pump.	Check oil. (See Lubrication and Maintenance section in the baler operator's manual.)

Continued on next page

Symptom	Problem	Solution
	Varying PTO speed while wrapping from one bale to the next.	Maintain rated PTO speed while wrapping. If difficult crop conditions require varying PTO speed while baling, return to rated speed at the “full bale” alarm.
	Flow valve lock ring is loose.	After adjusting flow valves for setting the number of wraps, tighten lock ring as indicated in Adjusting Number of Surface Wraps on The Bale in Operating Baler with Surface Wrap section.
	Change in ambient air temperature from previous operation.	If air temperature is greatly different from when number of wraps was adjusted, flow valve may need to be readjusted.
	Bale size and shape not uniform.	Tighten loose bale size adjustment knob. Make bales uniform in shape. Follow operating instructions in Operating the Baler section of the baler operator’s manual.
		NOTE: If wrapping a smaller bale with the manual pull rope, the small bale will have a higher number of wraps unless flow valve is readjusted.
Surface wrap is split around bale or stays behind the pickup.	Buildup of crop stems, etc, in lower gate belt guide area.	Remove buildup. In some crops, reducing PTO rpm will reduce buildup tendency. Ejecting bale with PTO running will reduce buildup in some conditions. Install Build-Up Reduction Scraper Kit. (See your John Deere dealer.)
	Extremely stemmy crops causing splitting or snagging.	Use more wraps of surface wrap material. Install Build-Up Reduction Scraper Kit.
	Insufficient clearance between ends of belt guide straps and cross member (lower gate belt guide).	Check for proper clearance. (See Servicing Lower Front Gate Roller in Service section.)
	Belts not tracking correctly.	See Adjusting Belt Tracking in Service section of baler operator’s manual.
	Material snagging on splices or pins.	Be sure end of belt pins are pointing toward smooth side of belt.

Continued on next page

Troubleshooting

Symptom	Problem	Solution
	End or corner of guide channel(s) bent upward into baler belt(s).	Reshape damaged end or replace with new part.
Surface wrap breaking due to excess tension.	Drive spring is stretched too far in drive position of brake arms.	Check idler position and adjust as necessary. (See Checking Drive Idler Adjustment in Service section.)
	Gas springs installed in wrong hole in brake arm.	Install in correct hole. (See Decreasing Brake Bar Tension in Service section.)
Bale wrapped normally, but cutoff signal does not activate.	Surface wrap microswitch needs adjustment.	Adjust. (See Adjusting Microswitch in Service section.)
	Gate latch needs adjustment. (Green light goes out while baling.)	Adjust gate latch. (See Adjusting Gate Latch Stop and Adjusting Gate Latch Switch (Green Light) in the Service section of the baler operator's manual.) Be sure green light is on before starting a bale.
	Right or left-hand gate latch microswitch out of adjustment or has failed (green light not on).	Adjust or replace switch. (See Adjusting Gate Latch Switch (Green Light) in Service section of the baler operator's manual.)
	Knife arm stop not adjusted properly.	Adjust knife arm correctly. (See Adjusting Knife Arm Stop in Service section.)
	Wrong return spring on cutoff indicator flap (surface wrap microswitch lever).	Replace with correct spring.
	Cutoff indicator flap binding on pivot bolts.	Check for bent or damaged parts. Repair or replace as necessary.
	Microswitch failed.	Check switch. Replace if necessary. (See Checking Microswitches in Service section of the baler operator's manual.)
	Wire connections unplugged, corroded, or dirty.	Inspect connections in harness next to oversize bale switch, just ahead of the surface wrap unit on right-hand side, and at the surface wrap microswitch.
Red light on BALE-TRAK monitor and surface wrap cutoff indicator does not function.	Gate latch switch is out of adjustment.	Adjust gate latch switch. (See Adjusting Gate Latch Switch (Green Light) in Service section of baler operator's manual.)
Cover does not stay open.	Weak gas spring(s).	Replace spring(s).

Continued on next page

Troubleshooting

Symptom

Problem

Solution

Broken surface wrap on bale, or large area of bale not covered by surface wrap.

Brake bar applies excessive tension on roll and surface wrap material.

Install gas springs in hole closest to brake pivot. (See Decreasing Brake Bar Tension in Service section.)

EX,435USO,AA1 -19-30OCT95

Service

PRACTICE SAFETY



CAUTION: Before servicing or adjusting baler:

1. Disengage all power.
2. Shut off engine
3. Wait until all moving parts have stopped.
4. Be careful when working around knife and feed rollers.

EX,435USP,A -19-15JUN90

ADJUSTING FEED ROLL PRESSURE

1. Release knife arm manually. (Refer to Releasing Knife Arm Manually in Operating Baler with Surface Wrap section.)
2. Open surface wrap cover.
3. Remove any foreign material or surface wrap from between the rolls.
4. Adjust spring length until 20.5 mm (25/32-in.) dimension (A) is obtained by loosening or tightening spring adjusting nut (B).
5. Repeat steps on opposite side.

NOTE: Too much pressure can cause surface wrap to wrap on rubber rolls. A lack of pressure will prevent surface wrap from being fed by the rolls to the bale or may cause poor placement of surface wrap material on the bale.

When knife arm brake is actuated by hydraulic force, it is normal for rolls to be slightly separated on one end or the other.

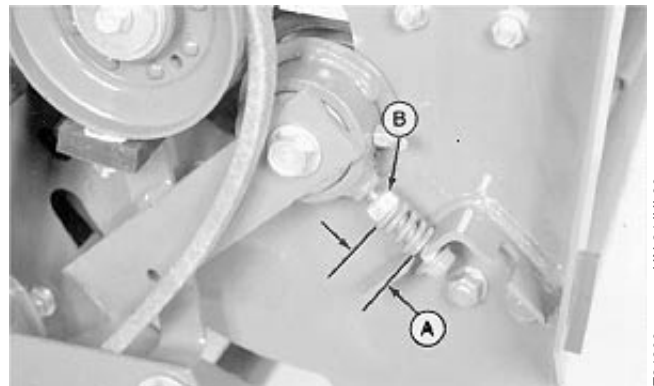

E34266 -UN-24JUL90

EX,435USP,B -19-27AUG90

CHECKING DRIVE IDLER ADJUSTMENT

1. Move knife arm manually. (Refer to Releasing Knife Arm Manually in Operating Baler with Surface Wrap section.)
2. Pull knife arm (A) back until belt is just tight (coils on spring are separated slightly). Cutting edge of knife (B) should be behind the corner of rear guide (C) at least 10 mm (13/32 in.) (D).
3. If top edge of knife (B) is less than 10 mm (13/32 in.) behind guide (C), the belt is too short. This condition can cause surface wrap to wrap on rubber rolls. Adjust idler in idler arm slot (E).

- A—Knife Arm
- B—Knife
- C—Guide
- D—10 mm (13/32 in.) Minimum
- E—Idler Arm Slot

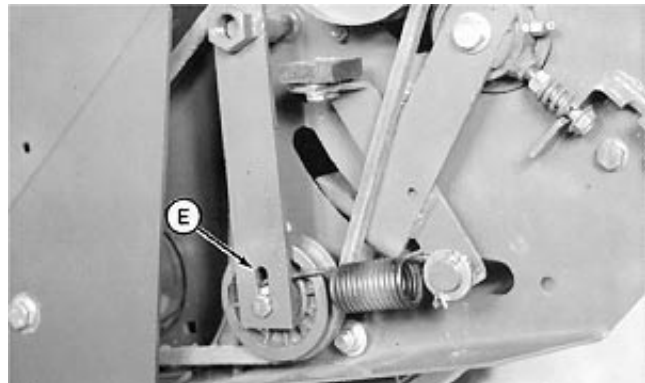
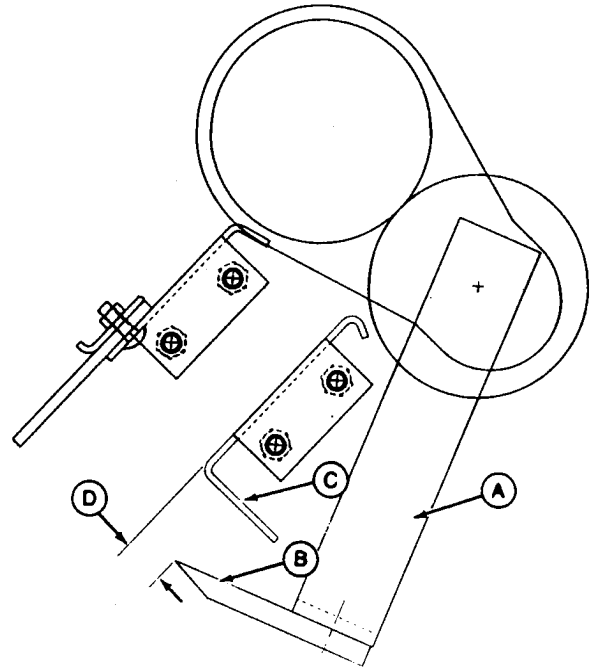

EX.435USP,C -19-23JUN92

-UN-29NOV88

E32645

-UN-22JUN92

E36889

REMOVING AND INSTALLING BELT

1. Lock gate.
2. Raise tension arm to release belt tension.
3. Shut off tractor.
4. Manually release knife arm. (See Releasing Knife Arm Manually in Operating Baler with Surface Wrap section.)
5. Remove cotter pin (A) and washer.
6. Remove gate roll support (B).
7. Remove belt (C) from surface wrap roll sheave and gate roll sheave.

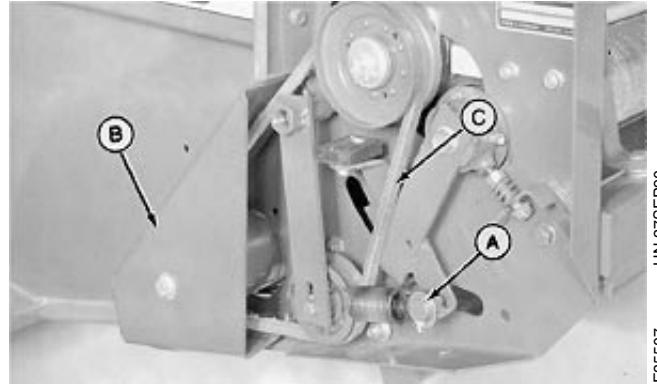

E33507 -UN-27SEP90

EX,435USP,D -19-18SEP90

8. Install new belt around surface wrap roll sheave (A), gate roll sheave (B), and idler (C).
9. Install spring (D). Fasten with washer and cotter pin.
10. Install gate roll support (E).
11. Check clearance between roll and side sheet.
12. Check for correct position of knife edge. (See Checking Drive Idler Adjustment in this section.)
13. Manually move knife arm forward to cut-off position.
14. Lower tension arm fully.
15. Unlock gate.
16. Check belt tracking. (See Adjusting Belt Tracking in the Service section of the baler operator's manual.)



E33502 -UN-27SEP90

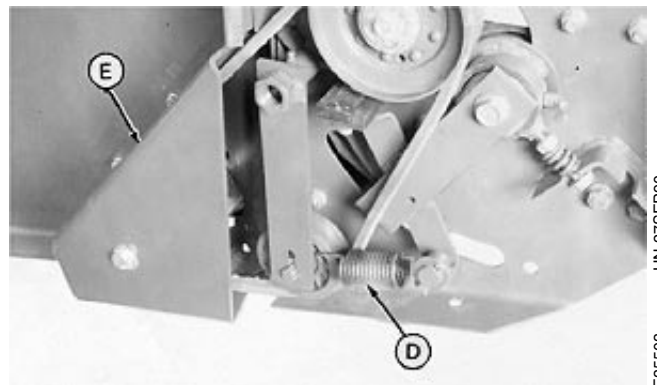

E33503 -UN-27SEP90

- A—Surface Wrap Roll Sheave
- B—Gate Roll Sheave
- C—Idler
- D—Spring
- E—Gate Roll Support

EX,435USP,E -19-23JUN92

REMOVING V-BELT IDLER ARM

1. Remove cotter pin (A) and washer.
2. Remove grease fitting (B) and idler arm assembly.

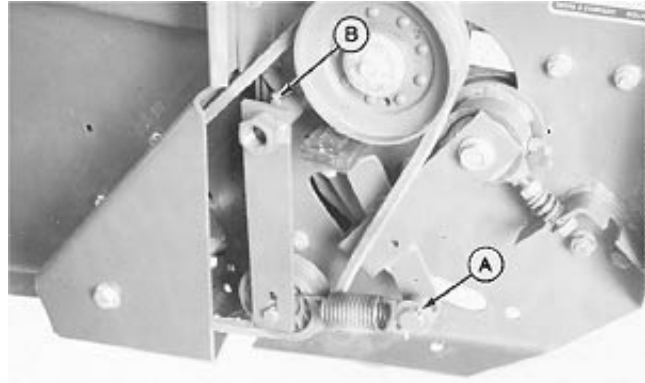

EX,435USP,T -19-17SEP90

E35504 -UN-27SEP90

REMOVING AND INSTALLING KNIFE

1. Pull down on handle (A) and open surface wrap cover.
2. Manually move knife arm back. (See Releasing Knife Arm Manually in Operating Baler with Surface Wrap section.)

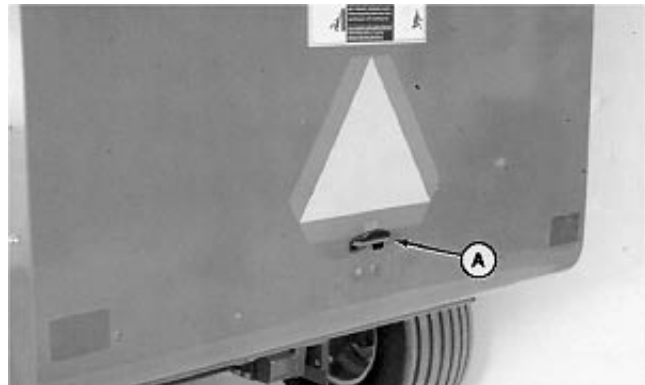

EX,435USP,F -19-27SEP90

E35383 -UN-28AUG90

CAUTION: Be careful when working around the knife. It is sharp.

3. Note position of knife cutting edge for reinstallation.
4. Remove bolts (A) and nuts on each end of knife (B). Remove knife from knife arms (C).
5. Reinstall knife (B) with bevel down, under knife arms (C).

NOTE: Round heads of bolts must be up.

6. Install bolts (A) and tighten to 55 N·m (40 lb-ft).
7. Manually push knife arm forward.

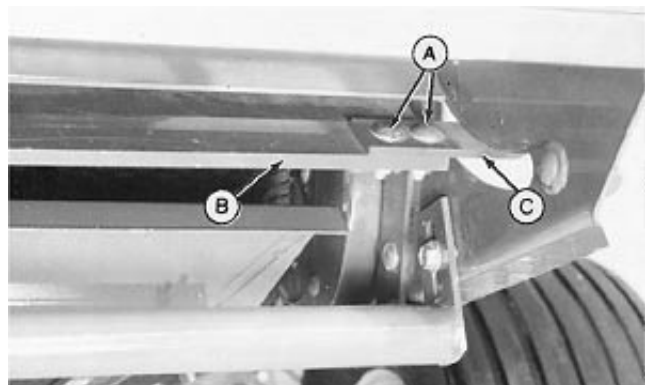

EX,435USP,G -19-23AUG90

E35385 -UN-28AUG90

CHECKING BRAKE

1. Check that surface wrap roll (A) will not rotate by hand when knife arm (B) is in its most forward position.
2. Manually release knife arm. (See Releasing Knife Arm Manually in Operating Baler with Surface Wrap section.)
3. Brake must be completely disengaged when knife arm is swung back and belt is tightened.

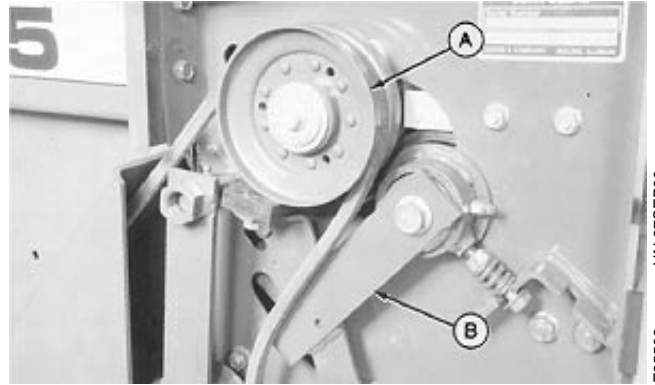

EX,435USP,H -19-18SEP90

E35508 -UN-27SEP90

4. When knife contacts stop bolt, brake (B) must be deformed by roll 1 to 2 mm (0.030 to 0.080-in.) (D).

If adjustment is required, pull knife arm (A) back. Install (or remove) washers as necessary, between rubber brake (B) and bracket (C).

NOTE: If worn, rubber brake pad can be reversed.

5. Check brake adjustment as described in steps 1 through 3.

6. Push knife arm forward.

- A—Knife Arm
- B—Rubber Brake
- C—Bracket
- D—1 to 2 mm (0.030 to 0.080-in.)

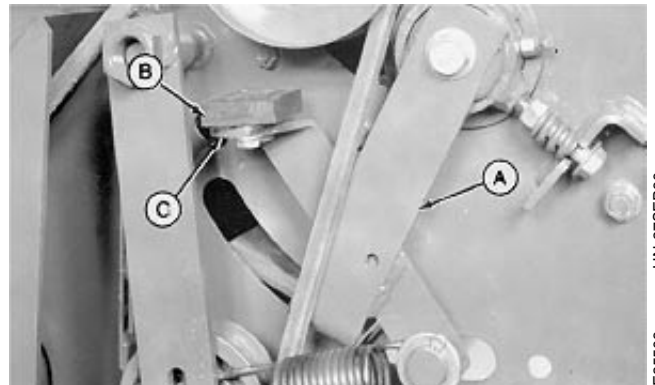

E35509 -UN-27SEP90

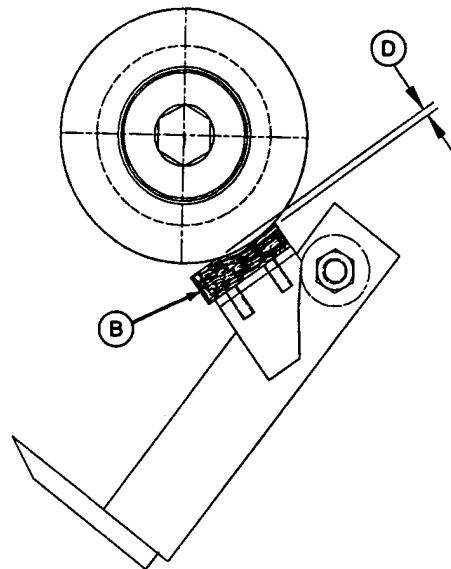

-UN-13OCT95

E39530

EX,435USP,S -19-17OCT95

ADJUSTING MICROSWITCH

1. Open surface wrap cover.
2. Check that switch lever (A) on right-hand side of surface wrap pivots freely. Lever must return freely under spring force.
3. Loosen both screws (B).
4. Move switch until switch arm (C) is fully compressed by pin on switch lever.
5. Tighten screws (B).
6. Close surface wrap cover.

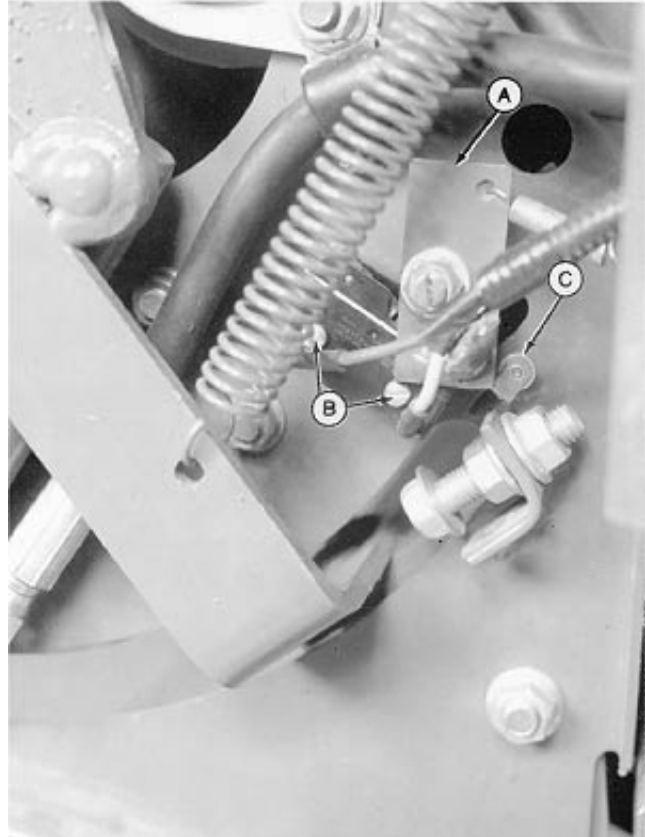

EX,435USP,I -19-27SEP90

E35386
-UN-28AUG90

REMOVING WRAPPAGE FROM FEED ROLLERS

IMPORTANT: Do not cut surface wrap material from rubber feed rolls. Any knife cuts in the rubber roll covering may result in more frequent wrapping around the rolls and may require roller replacement.

If surface wrap becomes wrapped around either of the rubber feed rolls:

1. Open the surface wrap cover.
2. Swing the knife arm back to release the brake. (See Releasing Knife Arm Manually in Operating Baler with Surface Wrap section.)



EX,435USP,JA1 -19-25SEP95

E34272
-UN-24JUL90

3. Pull surface wrap material away from the supply roll and spiral roll. Cut surface wrap material.



E34273 -UN-24JUL90

EX,435USP,K -19-21JUN90

4. Gather the free end of the surface wrap and lay over the top roll of wrap material.



E34274 -UN-24JUL90

EX,435USP,L -19-26JUN90

Service

5. Remove and discard all of the wrapped material, including all strings, staples, etc.

6. Wipe off rubber drive rolls and check for any sticky material. If necessary, rolls may be washed with soap and water. NEVER use solvents to clean rubber rolls. Allow rolls to dry before rethreading or wrappage may occur again.



EX,435USP,M -19-14SEP90

E34275
-UN-24JUL90

7. Rethread the surface wrap material. (See Threading Surface Wrap and Routing Through Rolls in Preparing Baler for Surface Wrap section.)

8. If static electricity or dampness causes surface wrap material to cling to the rolls, dust the rubber drive rollers with talcum powder such as A51237, available from your John Deere dealer.

EX,435USP,N -19-24JUN92

ADJUSTING ROLL SUPPORT BRACKETS

1. Place straight edge across both support brackets (A).



EX,435USP,V -19-20SEP90

E35513
-UN-27SEP90

2. Make sure contact between the straight edge and support brackets is 102 to 152 mm (4 to 6 in.) (A) from side panels.



EX,435USP,W -19-25SEP90

E35514
-UN-27SEP90

Service

3. If an adjustment is needed, put adjustable wrench (A) on outside edge of bracket. Adjust bracket until contact between the straight edge and bracket is 102 to 152 mm (4 to 6 in.) from side panel.



EX,435USP,X -19-23JUN92

E35515 -UN-27SEP90

ADJUSTING KNIFE ARM STOP

1. Remove nut (A) to remove rubber brake pad (B) and washers (if used).

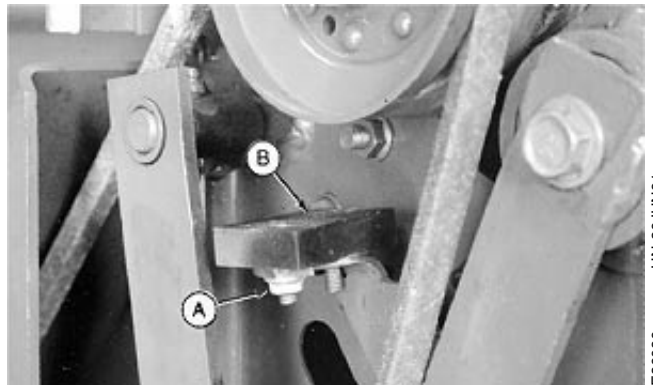

EX,435USP,OA1 -19-25SEP95

E36086 -UN-26JUN91

2. Push the knife arm (A) forward until arm contacts the stop bolt (B).

CAUTION: Knife is sharp. Use care when working around the knife.

NOTE: Knife may not contact belt over the entire length of the belt. Gaps may appear. This is due to natural waviness of the rubber strike belt.

3. Check that the front edge of the knife contacts the rubber strike belt but does not deflect the belt when the arm is against the stop bolt. The initial factory setting for the stop bolt length (C) is approximately 21 mm (13/16 in.).

NOTE: If light contact is not made, cut-off signal stays on, or cut-off signal is erratic or not activated, perform steps 3—5.

4. Manually release knife arm. (See Manually Releasing Knife Arm in this section.)

5. Adjust the stop position as required by loosening jam nut (D) and adjusting bolt (B) until light knife contact is made (knife contacts rubber strike belt but does not deflect belt).

- If the knife contacts the rubber flap too hard:
 - a) Material may wrap on upper surface wrap roll. If so, lengthen bolt (B) 1/2 turn at a time.
 - b) Knife may clamp the wrap material after it is cut and cause the cutoff signal (buzzer, red light and green light) to stay on. If cutoff signal stays on, lengthen bolt (B) 1/2 turn at a time.
- If the knife does not move far enough forward, the surface wrap material may not cut off, the cutoff signal may not come on and/or cut end of material may tend to wrap around the rubber rolls when the next wrapping cycle starts. If cutoff signal is not heard or is erratic, shorten bolt (B) 1/2 turn at a time.

6. Tighten jam nut (D).

7. Install rubber brake pad, washers, and nuts.

8. Adjust drive roll brake. (See Checking Brake in this section.)

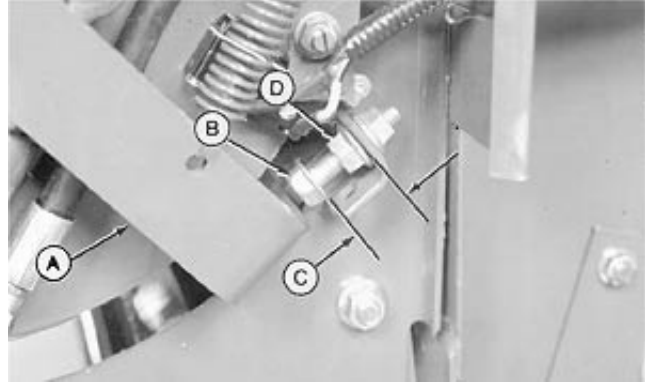

A—Knife Arm
 B—Stop Bolt
 C—21 mm (13/16 in.) Initial Setting
 D—Jam Nut

E34276 -UN-24JUL90

INCREASING BRAKE BAR TENSION

In certain conditions, friction between surface wrap material and stainless steel supports may be too low, causing one or more of the following symptoms:

- Surface wrap material loose on bale.
- Surface wrap material less than full width of bale.
- Surface wrap roll continues to turn after cutoff, causing material to wrap on rubber drive roll.
- Surface wrap material appears loose on ends of rubber rolls or on roll of surface wrap.

If any of the above conditions occur:

- Make sure the approved surface wrap material is being used.
- Increase tension on brake bar.

Increase tension on brake bar by moving gas springs (A) to alternate hole positions.

NOTE: Support surface wrap cover while removing and installing gas spring.

To relocate gas springs:

1. Remove gas spring from one side.
2. Reposition other gas spring to desired position.
3. Reposition first gas spring.

This procedure will prevent binding and make repositioning of springs easier.

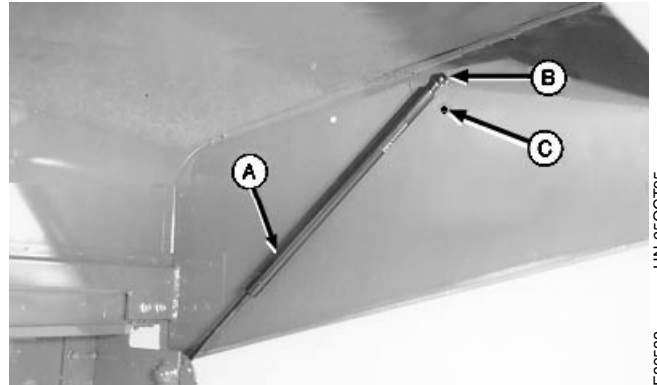

-UN-25OCT95
E39532

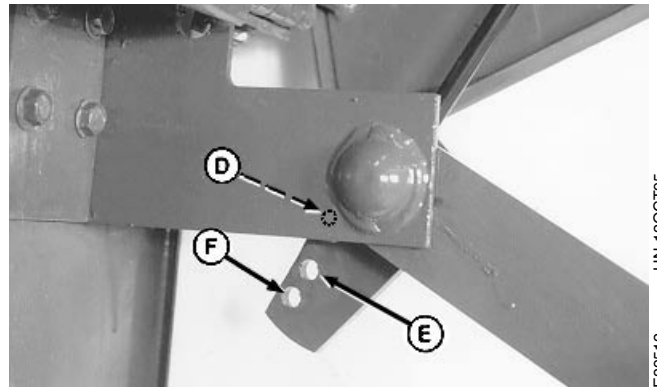

-UN-12OCT95
E39512

BRAKE BAR TENSION	HOLE POSITION (COVER)	HOLE POSITION (BRAKE ARM)
Lowest—Normal Position (435)	B	D
Medium—Normal Position (535) —Optional Position (435)	B	E
Highest—Optional Position (535 Only)	C	F

DECREASING BRAKE BAR TENSION

In certain conditions, friction between surface wrap material and stainless steel supports may be too high, causing one or more of the following symptoms:

- Breaks in surface wrap material causing ruptures from bulges of crop material.
- Surface wrap roll will not rotate and feed onto bale.
- Surface wrap material is tight on some areas of the bale and loose on other areas.
- Surface wrap material is split around the bale.
- Plastic, powder-like residue is present on stainless steel supports.

If any of the above conditions occur:

- Make sure the approved surface wrap material is being used.
- Decrease tension on brake bar.

Decrease tension on brake bar by moving gas springs (A) to alternate hole positions.

NOTE: Support surface wrap cover while removing and installing gas springs.

To relocate gas springs:

1. Remove gas spring from one side.
2. Reposition other gas spring to desired position.
3. Reposition first gas spring.

This procedure will prevent binding and make repositioning of springs easier.

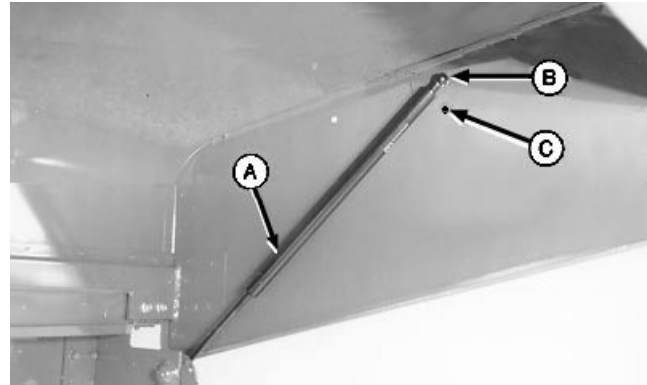

-UN-25OCT95
E39532

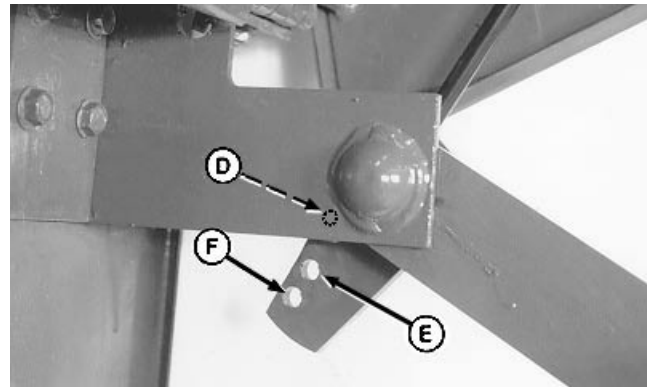

-UN-12OCT95
E39512

BRAKE BAR TENSION	HOLE POSITION (COVER)	HOLE POSITION (BRAKE ARM)
Lowest—Normal Position (435)	B	D
Medium—Normal Position (535) —Optional Position (435)	B	E
Highest—Optional Position (535 Only)	C	F

SERVICING LOWER FRONT GATE ROLL

1. Raise gate fully until lower front gate roll is approximately 1 m (3-1/3 ft) above the ground.
2. Lock gate. Shut off tractor.
3. Remove two cap screws (A) holding front corners of lower surface wrap guide assembly to belt guide.
4. Swing assembly (B) away from gate roll.
5. Service gate roll as necessary.

IMPORTANT: Do not lower gate with the lower surface wrap guide assembly detached from the belt guide or damage to the guide will result.

IMPORTANT: Do not operate the baler belts with the lower surface wrap guide assembly detached from the belt guide, or belt damage may result.

6. Lower tension arm. Shut off tractor.



-UN-24JUL90
E34277

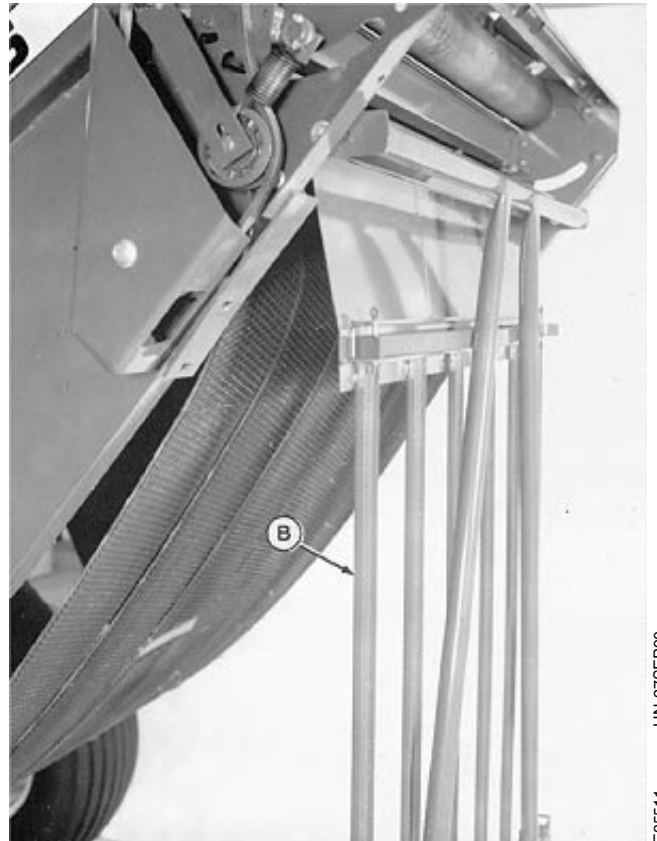

-UN-27SEP90
E35511

EX,435USP,P -19-19SEP90

7. Position belts between guide straps (A).
8. Swing assembly toward the roll.
9. Align the holes and attach with bolts.
10. Check and adjust clearance between ends of all belt guide straps and the bottom crossmember. There must be 2 to 4 mm (3/32 to 5/32 in.) clearance.

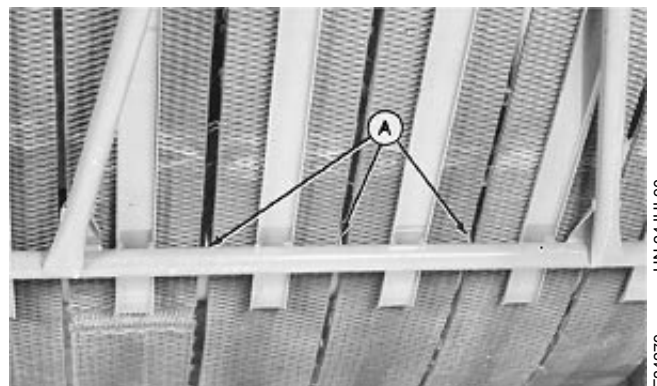

-UN-24JUL90
E34279

EX,435USP,Q -19-14SEP90

BLEEDING HYDRAULIC CIRCUIT

1. Check oil level in twine pump. Fill if necessary. Use John Deere Low Viscosity HY-GARD® oil. (See Lubrication and Maintenance section in baler operator's manual.)
2. Loosen cylinder hydraulic fittings (A) just enough to let trapped air escape.
3. Open all three valves (B) by turning fully counterclockwise.
4. Lock gate in closed position with gate lock valve.

⚠ CAUTION: Make sure all bystanders are clear before starting baler. Stay clear of baler while it is running.

5. Raise tension arm fully.
6. Engage PTO.

Twine arm and surface wrap will cycle. However, bale forming belts will not turn and V-belt drive does not rotate.

IMPORTANT: Do not operate more than one minute in this mode or bale forming belts may be damaged.

NOTE: Surface wrapping is a fast process. When adjusted for normal operation, it only takes about 5 to 10 seconds for a complete cycle. It may be helpful to slow the process down by turning both flow control knobs clockwise approximately one turn each, to allow more time for observation.

7. Disengage PTO. Shut off tractor engine.
8. Refill twine pump hydraulic reservoir.
9. Start tractor engine and engage PTO.
10. To recycle, pull and release twine rope.
11. Disengage PTO. Shut off tractor engine.
12. Tighten hydraulic fittings.
13. Refill twine pump hydraulic reservoir if necessary.



E34317 -UN-24JUL90

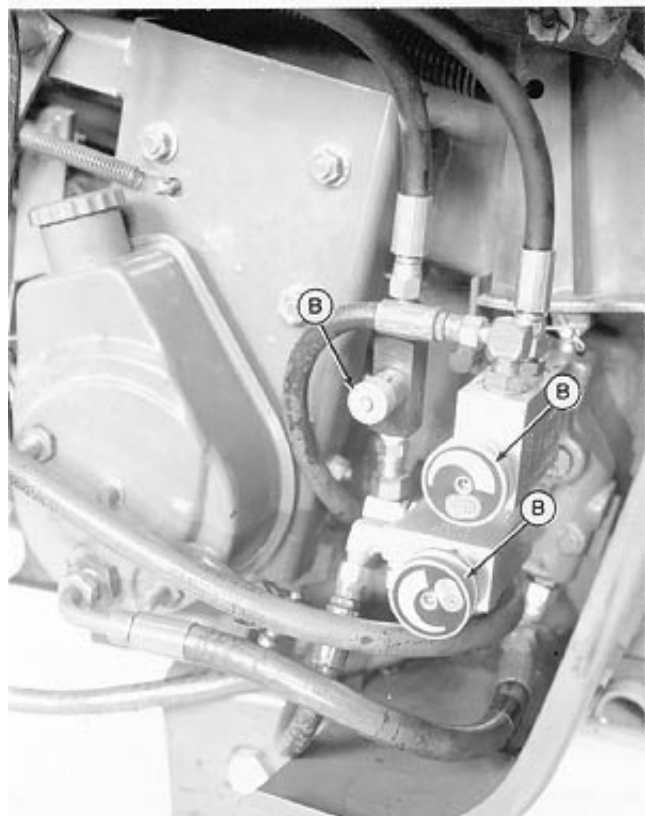

E34318 -UN-24JUL90

SURFACE WRAPPING HYDRAULIC SYSTEM

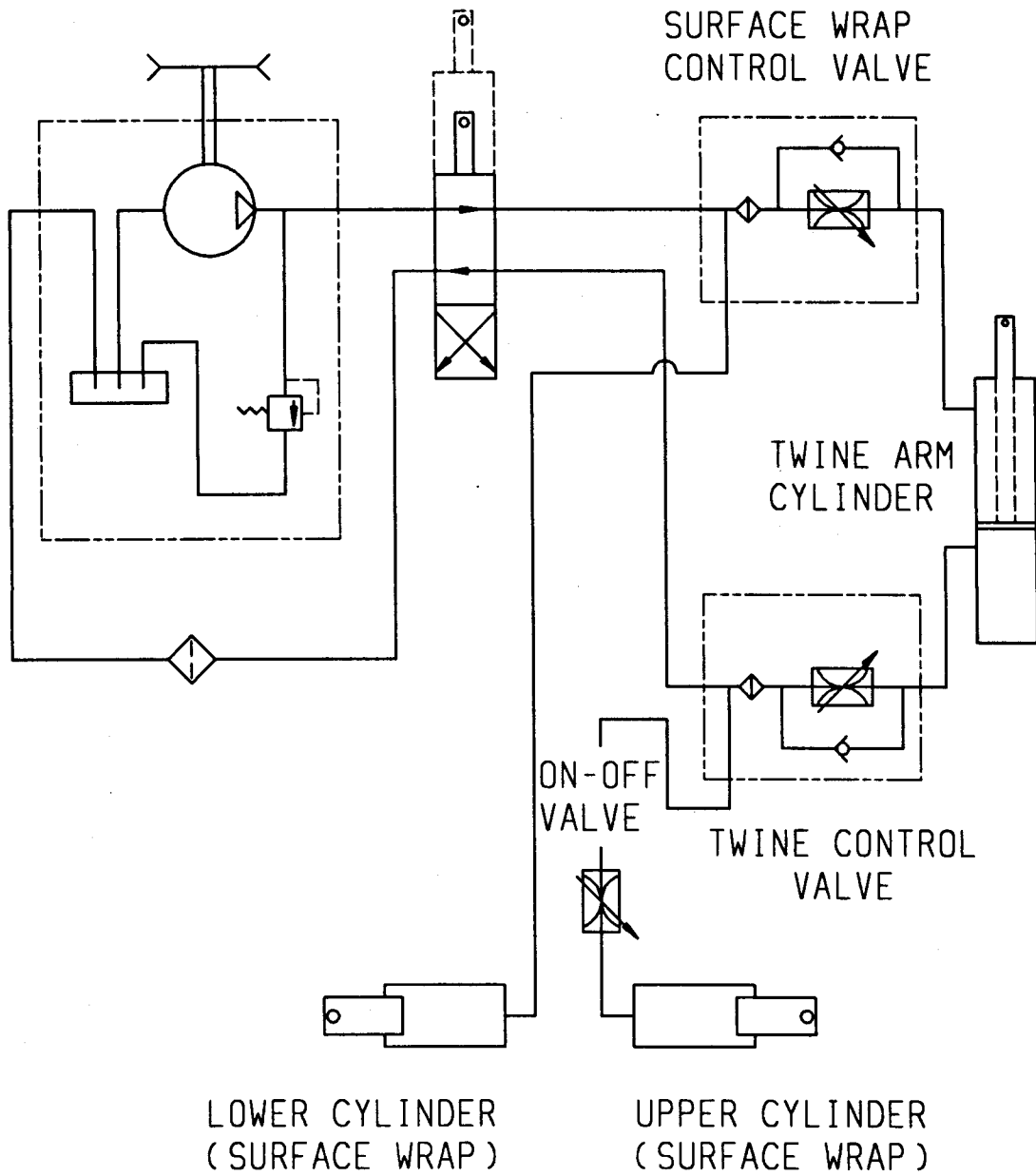

EX,435USP,R -19-10OCT90

E35530 -19-03OCT90

Surface Wrap Assembly

INSPECT BALER STARTER ROLL

IMPORTANT: Be sure there is adequate ceiling clearance before opening the gate if working indoors.

1. Open and lock gate.
2. Check starter roll surface for nicks, welds, slag, or other imperfections which can snag surface wrap material from the bale. If necessary, file smooth the rough areas on the roll.

EX,435USR,BE -19-08FEB91

INSTALL WHEEL SPINDLE EXTENSION PLATES

1. Jack up left-hand side of baler. Remove wheel and spindle (A).
2. Install plate (B), counterbored holes facing toward machine, with four existing M16 x 160 cap screws (C). Tighten cap screws to 235 N-m (177 lb-ft).
3. Install spindle (A) on plate (B) with four M16 x 50 cap screws (D). Put heads of cap screws to the inside of baler and through the top and third slots of spindle. Install four existing 17 x 34 x 4 mm washers (F), and nuts (E). Tighten cap screws to 235 N-m (177 lb-ft).
4. Reinstall wheel with six 1/2 x 1-1/2 in. wheel bolts. Tighten to 115 N-m (85 lb-ft).
5. Repeat on right-hand side.

A—Spindle
B—Plate
C—M16 x 160 Cap Screws
D—M16 X 50 Cap Screws
E—Nuts
F—17 x 34 x 4 mm Washers

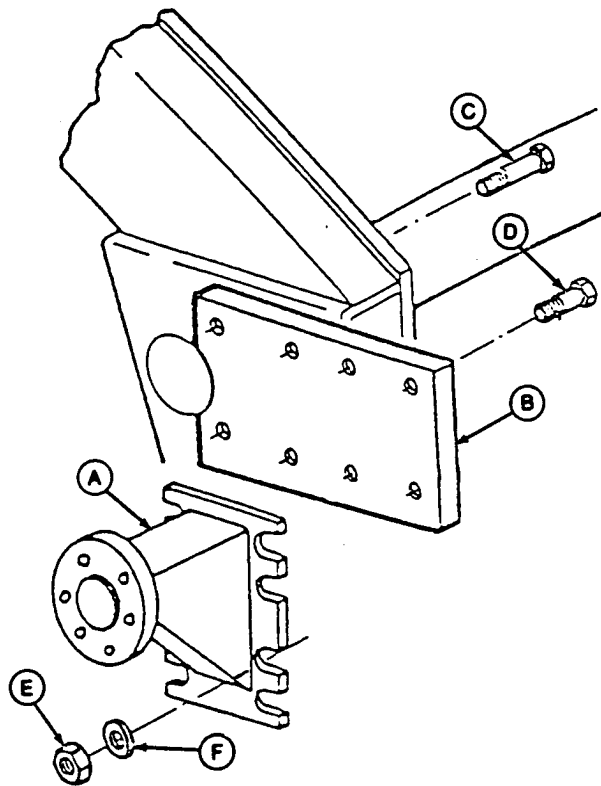

-UN-24JUL90
E34281

EX,435USR,BA1 -19-25SEP95

INSTALL GATE ORIFICE

1. Remove hose (A) from elbow (B).
2. Remove elbow (B) from gate lock valve (C).
3. Install O-rings on fitting (E) and install in valve (C).
4. Install flow restrictor valve (D) on fitting (E) with pin (F) closest to bottom.
5. Install elbow (B) into top of flow restrictor (D) as shown.
6. Attach hose (A) to elbow (B).

A—Hose
B—Elbow
C—Gate Lock Valve
D—Flow Restrictor
E—Fitting
F—Pin

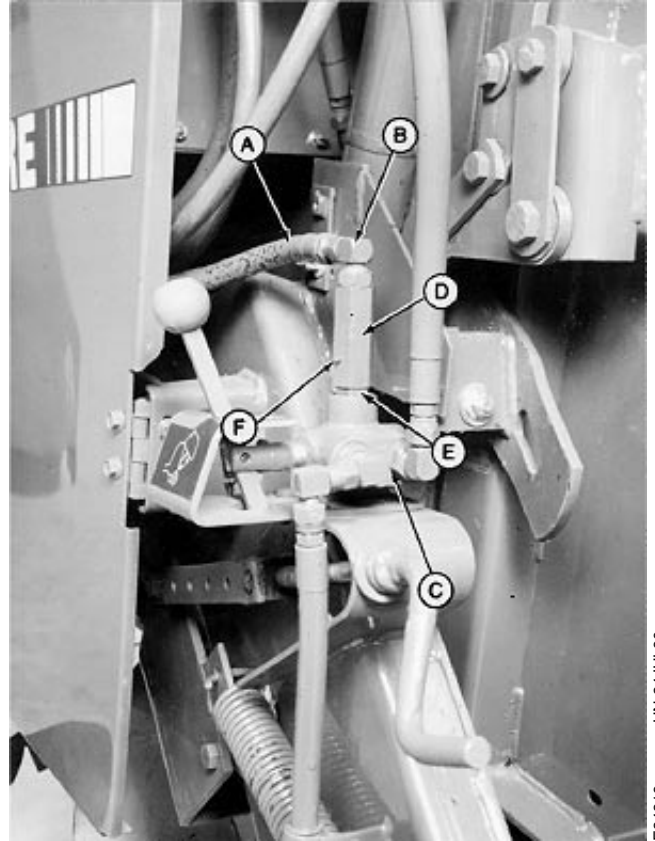

E34319 -UN-24JUL90

EX,435USR,AR -19-05DEC90

REMOVE LOWER REAR GATE ROLL

1. Open rear gate slightly.
2. Lock the gate.
3. Raise belt tension arm with tractor selector control valve lever.
4. Remove roll (A) from gate by removing right-hand mounting screw (B), left-hand mounting screw (C), mounting plate bolts and nuts (E), and mounting plate (D).

- Retain right-hand mounting screw (B), 17/32 x 1-1/4 x 0.180-in. washer, and spacer (F). (Spacer used on 435 only.) Discard 17/32 x 1-1/4 x 0.105-in. washer between mounting plate and right-hand end of shaft.

- Retain left-hand mounting screw and 17/32 x 1-1/4 x 0.180-in. washer (C).

- Discard left-hand mounting plate (D), mounting plate bolts and nuts (E), 17/32 x 1-1/4 0.105-in. washer and left-hand spacer (G). (Spacer used on 435 only.)

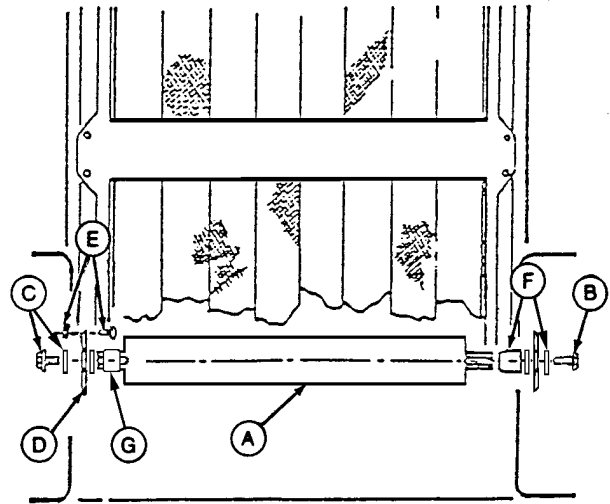

- A—Roll
- B—Right Hand Mounting Screw
- C—Left Hand Mounting Screw
- D—Mounting Plate
- E—Mounting Plate Bolts and Nuts
- F—Right-Hand Spacer
- G—Left-Hand Spacer

EX,435USR,C -19-26SEP95

-JUN-26SEP95
E39509

ADAPT BALERS WITH SERIAL NUMBERS 880000 AND BELOW FOR SURFACE WRAP

1. Fasten left-hand drive support to roll with M12 x 25 cap screw (A).
2. Install spacer plate (B) and left-hand strap (C) on gate. Fasten with two M8 x 25 self-tapping screws (D).

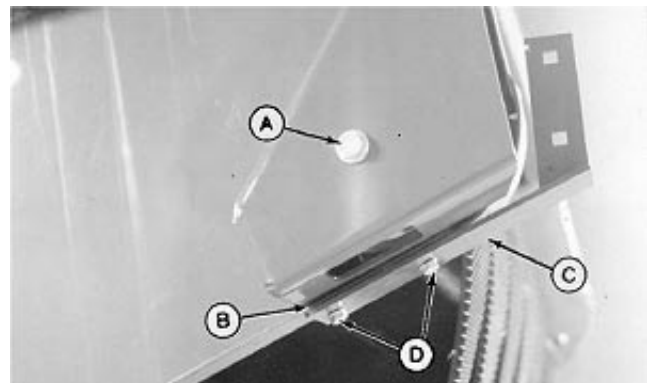

EX,435USR,H -19-21JUN90

-JUN-24JUL90
E34286

Surface Wrap Assembly

3. Mark location of holes to be drilled.

4. Remove drive support and drill three 9 mm (11/32-in.) holes. File holes square.



E34287
-UN-24JUL90

EX,435USR,I -19-23AUG90

5. Drill two 10.5 mm (13/32-in.) holes (B) in rear gate (one on each side) 43 mm (1-11/16 in.) (A) above slot.

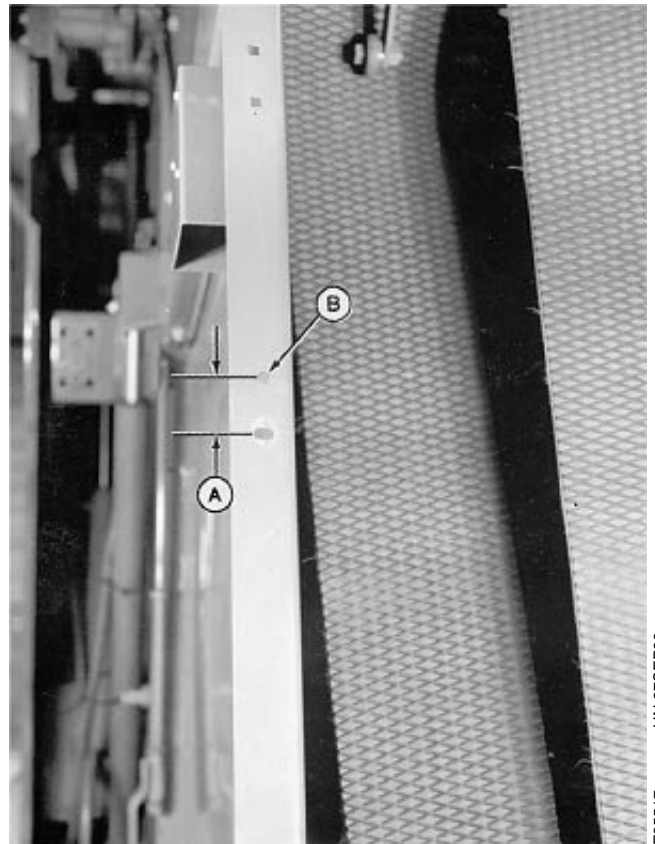

E35517
-UN-27SEP90

EX,435USR,J -19-23JUN92

ADAPT BALERS WITH SERIAL NUMBERS 922724 AND BELOW FOR SURFACE WRAP

Relocate two 9 mm (11/32-in.) square holes above upper gate channel for transport light bar.

- A—480 mm (18-29/32 in.)
- B—45 mm (1-25/32 in.)
- C—25 mm (31/32 in.)

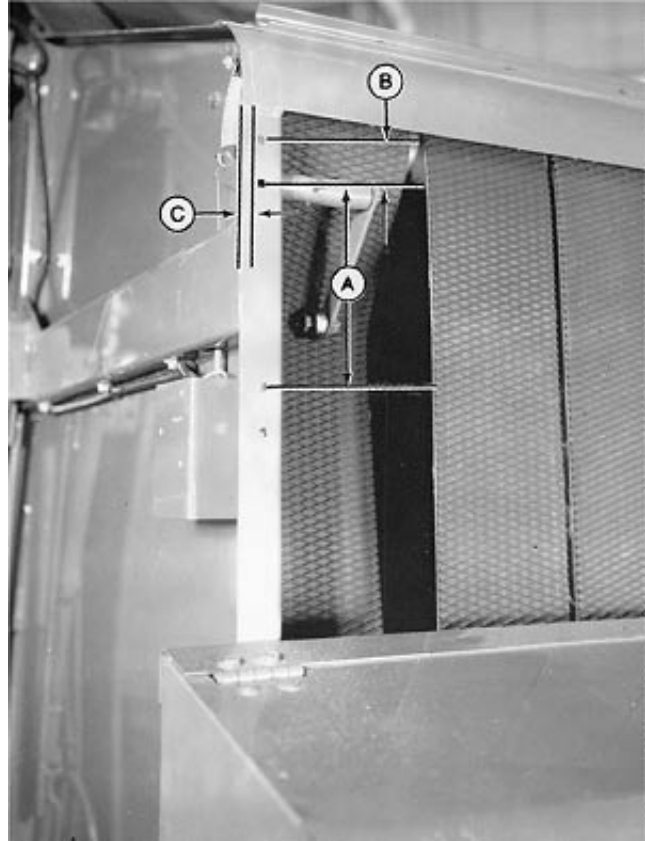

EX,435USR,AY -19-02OCT95

E35516 -UN-27SEP90

INSTALL SURFACE WRAP DRIVE ROLL

1. Reinstall spacer on right-hand end of shaft. (535 spacer is in bag of parts.)
2. Slide roll (A) through gate so pulley (B) is located on left-hand side as shown.
3. Install V-belt (C) on roll (A).

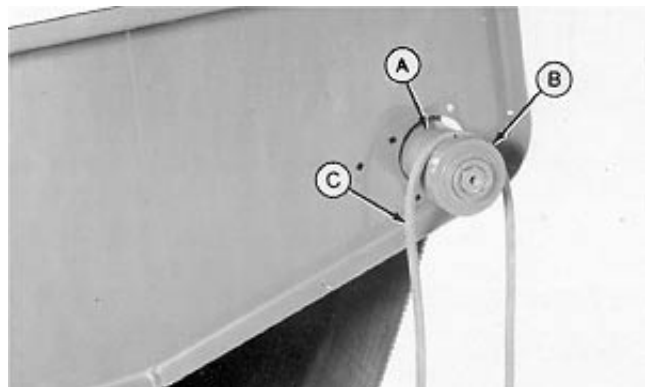

EX,435USR,F -19-14SEP90

E34284 -UN-24JUL90

4. Position drive roll in the center of slot (A) on right-hand side of gate. Fasten with existing screw (B) and washer.

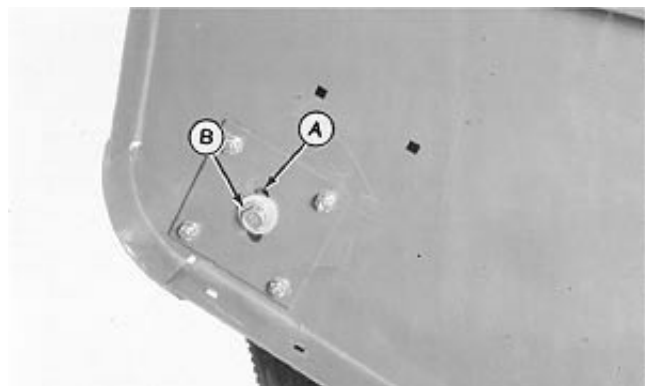

EX,435USR,G -19-21JUN90

E34285 -UN-24JUL90

INSTALL SURFACE WRAP DRIVE ROLL SUPPORT

NOTE: Be sure V-belt is on sheave before installing support.

1. Fasten left-hand drive support to roll with M12 x 25 cap screw (A).
2. Install three M8 x 20 round-head bolts and nuts (B).
3. Install spacer plate (C), with slot toward the rear, and left-hand strap (D) on gate. Fasten with two M8 x 25 self-tapping screws (E). Do not tighten at this time.
4. Install right-hand strap and spacer plate using two M8 x 25 flange-head screw and flange nut.
5. Make sure roll is centered in side sheet hole.
6. Check that roll has a lateral play of 1 to 4 mm (0.04 to 0.15 in.). Correct, if necessary, by adding 36 x 45 x 1 mm washers on hex shaft between the roll and roll support on right-hand end of shaft.
7. Tighten the two roll mounting screws (A) to 90 N·m (65 lb-ft).
8. Unlock and close the gate.

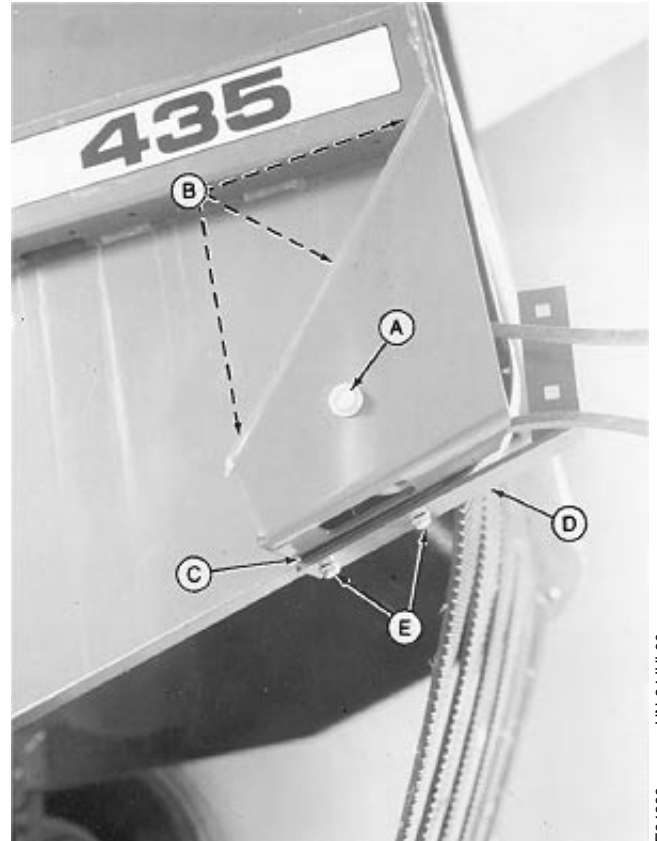

E34289 -UN-24JUL90

- A—M12 x 25 Cap Screw
- B—Nuts
- C—Spacer Plate
- D—Left-Hand Strap
- E—M8 x 25 Self-Tapping Screws

EX,435USR,K -19-22SEP95

REMOVE SMV ASSEMBLY

Remove SMV symbol and bracket from baler. SMV assembly will not be reinstalled on surface wrap attachment.

EX,435USR,BC -19-17JAN91

INSTALL SURFACE WRAP ATTACHMENT

1. Attach chain hoist to lifting brackets (A).



E34290 -UN-24JUL90

EX,435USR,L -19-17JAN91

Surface Wrap Assembly

IMPORTANT: Do not pry or loosen bolts to line up surface wrap with baler frame holes. This may cause operating problems with the surface wrap attachment.

2. Hoist unit into place. Align bolt through holes in baler sides. Install three flange nuts (A) on each side.

3. File lower mounting holes (B) equally on both sides of the rear gate, if necessary, to align with surface wrap bolts.

4. Unhook hoist and rotate chain lift bracket down behind front sheet.



E39510 -UN-17OCT95

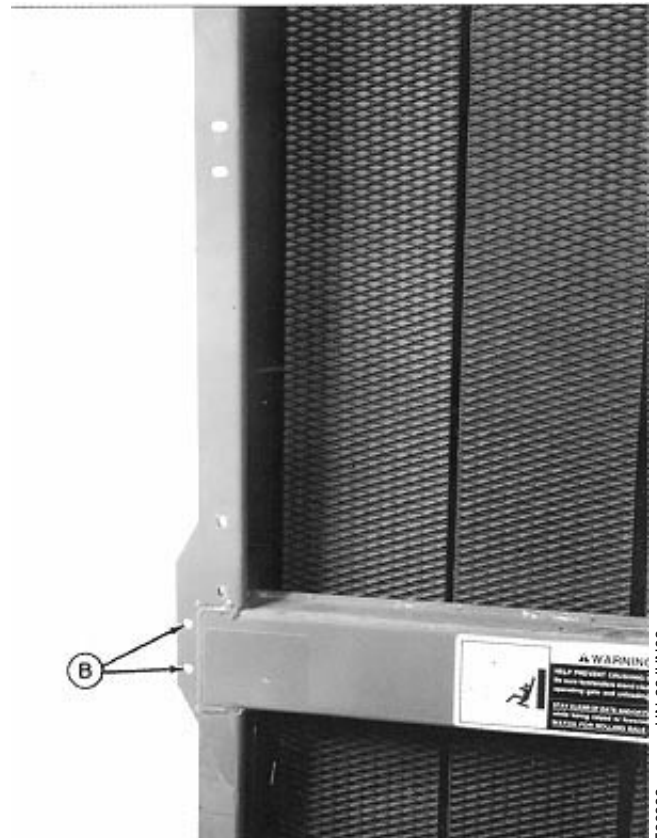

E36882 -UN-22JUN92

EX,435USR,M -19-28SEP95

Surface Wrap Assembly

5. Lift and support surface wrap cover.

6. Remove nut and bolt (A) from brake arm and roll plate. Repeat on opposite side.

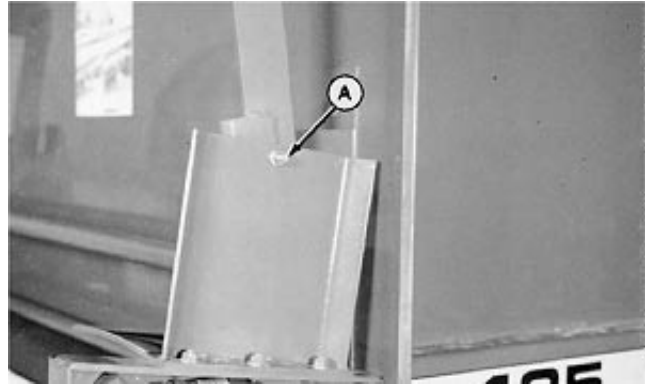

EX,435USR,N -19-23JUN92

E35387 -UN-28AUG90

Check surface wrap cover and brake bar pivots for hole locations before installing gas springs.

- Make sure surface wrap cover is equipped on both sides with a hole at location (A).
- Make sure brake bar pivots have a hole at location (B).

If the holes already exists, proceed to step 7.

If not, refer to the following instructions.



Surface Wrap Cover

E39541 -UN-18OCT95

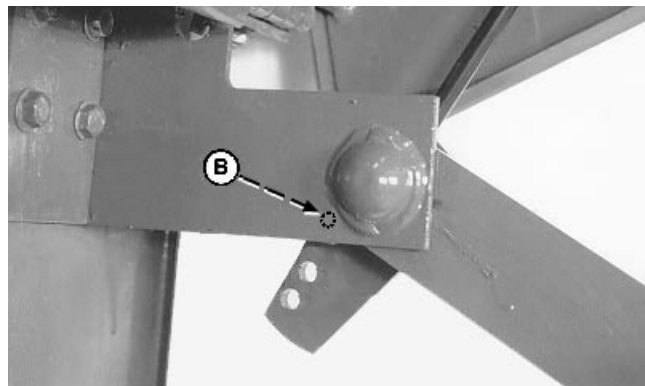

Brake Bar Pivot

E39542 -UN-18OCT95

EX,435USR,BL -19-19OCT95

Adding holes to surface wrap cover:

- Drill 9 mm (11/32-in.) hole (A) in left-hand side of cover, 46 mm (1-13/16 in.) from center of existing hole. Repeat on right-hand side.

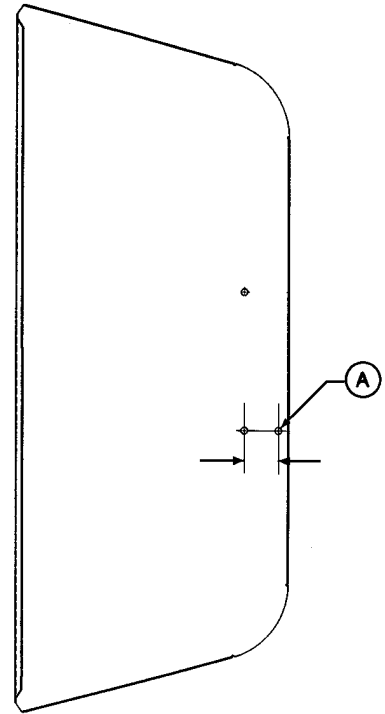

Surface Wrap Cover

Adding hole to brake bar pivot:

- Drill 9 mm (11/32-in.) hole (B) in brake bar pivot. Repeat on opposite side.

- B—9 mm (11/32-in.) Hole**
- C—39 mm (1-17/32 in.)**
- D—55.5 mm (2-3/16 in.)**

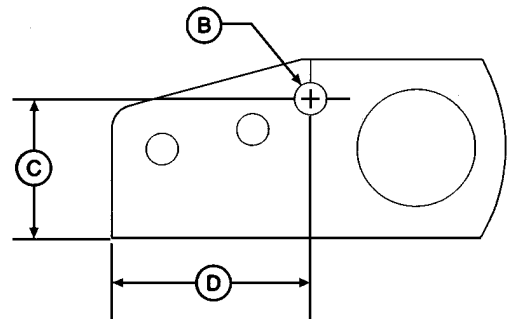

Brake Bar Pivot

EX,435USR,BM -19-20OCT95

E39543 -UN-19OCT95

E39544 -UN-24OCT95

Surface Wrap Assembly

IMPORTANT: Avoid bumping or damaging rods when installing gas springs, as this could lead to gas leaks.

7. Install gas spring (A) in rear hole (B) as shown. Fasten to cover with washer and M8 nut. Tighten to 25 N-m (18 lb-ft).

8. Install gas spring stud in hole (C) for 435 Baler or hole (D) for 535 Baler. Install M8 nut and tighten to 25 N-m (18 lb-ft).

9. Repeat on opposite side.

- A—Gas Spring
- B—Hole
- C—Normal Operating Position (435)
- D—Normal Operating Position (535)

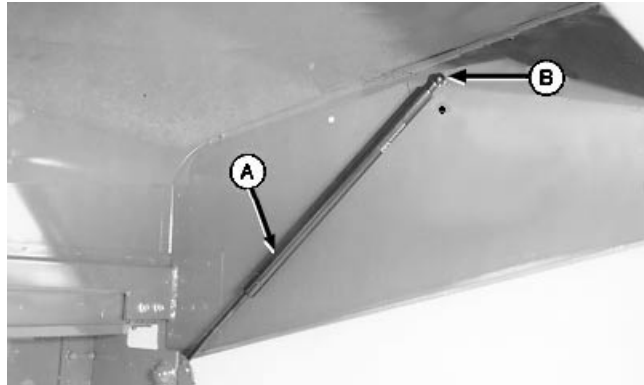

-UN-25OCT95
E39534

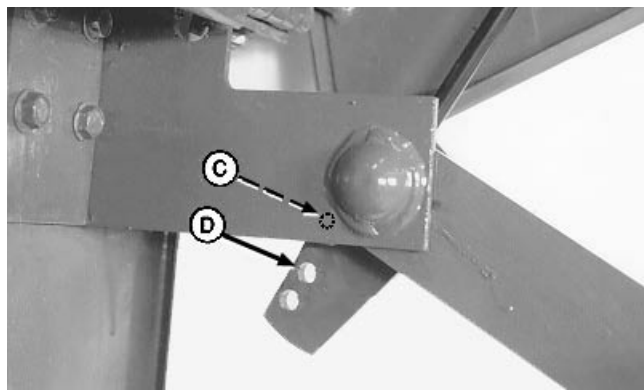

-UN-24OCT95
E39535

EX,435USR,O -19-24OCT95

10. Install M8 x 25 flange-head screw and flange nut (A). Repeat on opposite side.

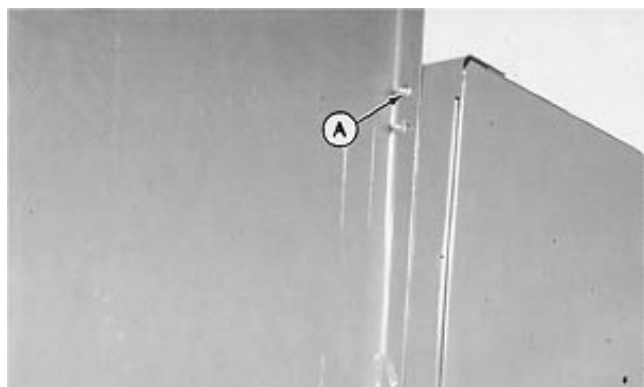

-UN-24JUL90
E34293

EX,435USR,P -19-23JUN92

11. Attach mounting bracket to right-hand side of surface wrap frame with two M10 x 20 round-head bolts and nuts (A). Repeat on opposite side.

12. Tighten all bolts previously installed.

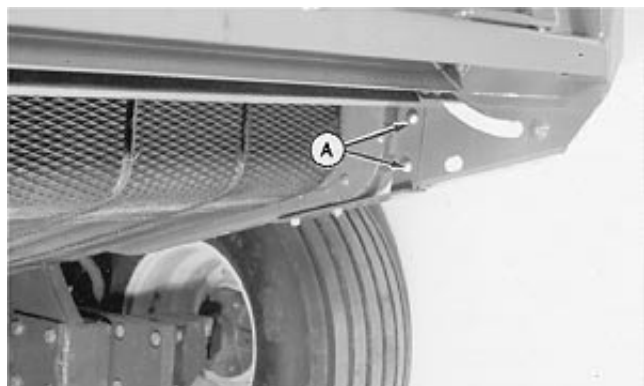

-UN-27SEP90
E35505

EX,435USR,Q -19-23JUN92

LEAVE PROTECTIVE TAPE ON HINGE AREA

IMPORTANT: Do NOT remove tape from hinge area. The tape helps prevent rust from forming on the surface wrap area.

Do NOT remove tape from hinge area (A). The tape helps eliminate moisture and dust from getting into the surface wrap area and causing rust.

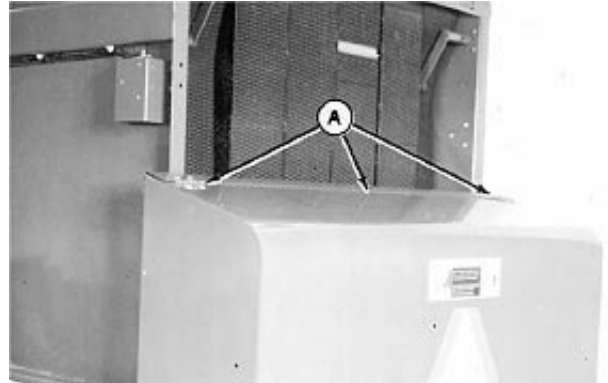

EX,435USR,BI -19-16JUL92

E36895 -UN-25JUN92

REMOVE PROTECTIVE COVERS

Remove plastic protectors (A) from stainless steel brackets on both sides of unit.

If necessary, remove premesh covering from any decal including SMV emblem.

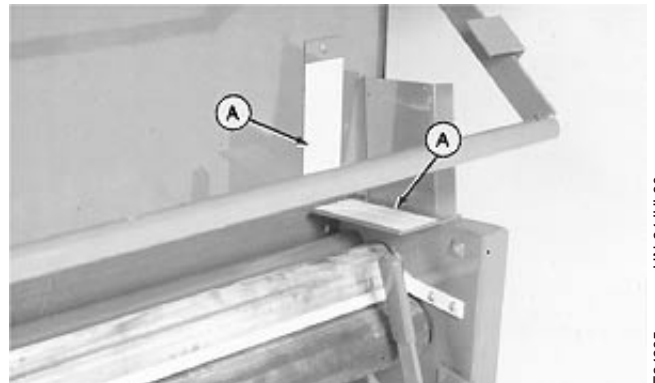

EX,435USR,R -19-25JUN92

E34295 -UN-24JUL90

INSTALL V-BELT

1. Remove shipping wire from idler pulley.
2. Remove cotter pin (A) and washer.
3. Move idler spring (B) out of the way.

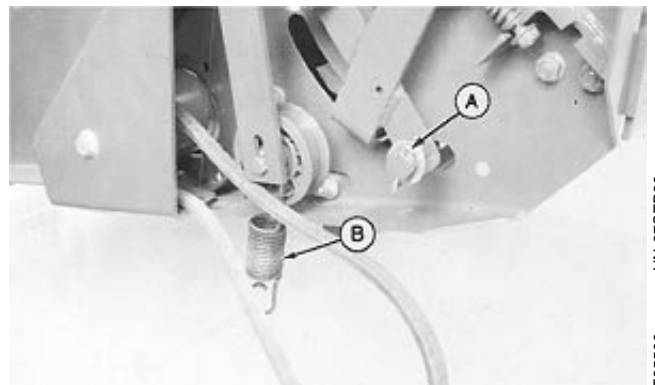

EX,435USR,S -19-17SEP90

E35506 -UN-27SEP90

4. Install belt (A) around sheaves.
5. Attach idler spring (B) to knife arm with washer and cotter pin (C).

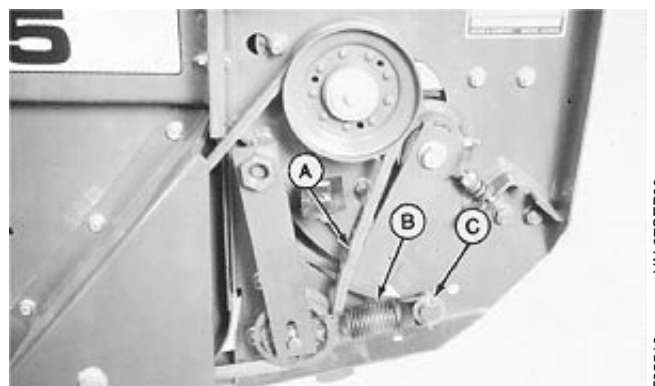

EX,435USR,AU -19-18SEP90

E35510 -UN-27SEP90

CHECK COVER LATCH

IMPORTANT: Check operation and adjustment of cover latch. Improper latch adjustment can result in the cover opening and loss of surface wrap material out of the unit.

Check for proper latching of unit:

1. Close the cover using a light closing force.
2. The latch hook (A) should engage the entire thickness of the cross angle (B). If not, adjust cross angle and latch stop nut. (See Adjust Cover Latch in this section.)

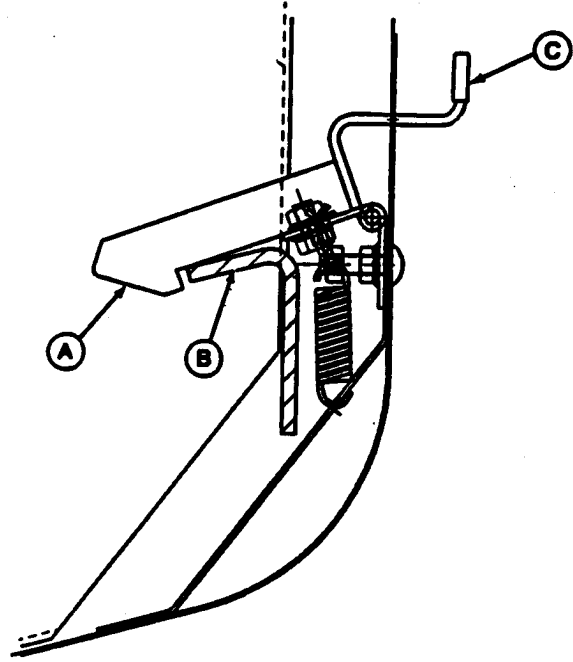

E36683 -UN-22JUN92

EX,435USR,BF -19-23JUN92

ADJUST COVER LATCH

1. Adjust stop nut (A) on latch until handle (B) is approximately 20 mm (0.79 in.) (C) from cover.
2. Adjust cross angle (D) by loosening attaching bolts to obtain a 0.5 mm to 2 mm (0.020 to 0.080-in.) gap (E) between cross angle and latch (F).
3. Check for full engagement and latch hook clearance by looking up through the hand hole in bottom of cover.



E36884 -UN-22JUN92

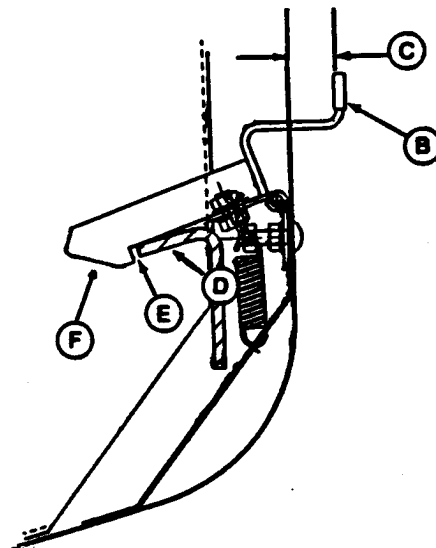

E36885 -UN-22JUN92

EX,435USR,BG -19-23JUN92

INVERT LIFT STRAPS

1. Remove lift straps after unit is attached to baler.
2. Reinstall lift straps with bent leg forward. Leave lock nuts loose enough so straps can pivot down out of the way.

NOTE: Lift straps should be left on the unit. If unit has to be removed, lift straps can be used.

EX,435USR,BH -19-23JUN92

REMOVE LOWER FRONT BELT GUIDE

1. Open gate approximately 1 m (3-1/3 ft) above the ground.
2. Lock the gate.
3. Remove mounting straps, mounting screws (A), washers, and nuts from guide (B). Discard all parts removed.
4. Remove lacing pins from each belt to disengage belt from belt guide.
5. Route each belt outside and around belt guide.
6. Install new lacing pins. **Be sure bent ends of pins point toward inside (smooth side of belt) to avoid snagging wrap material.**
7. Remove belt guide from baler.
8. Remove scraper from belt guide. Retain scraper and hardware. Discard belt guide.

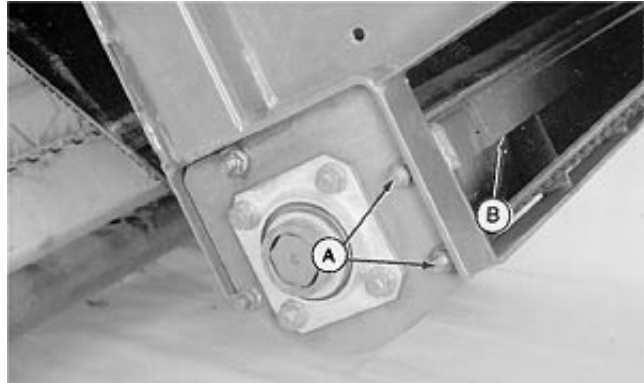

E34298 -UN-24JUL90

EX,435USR,T -19-23JUN92

INSTALL NEW LOWER FRONT BELT GUIDE

1. Remove protective cover from pan assembly.
2. Remove belt guide (A) from assembly.

NOTE: Parts were assembled together for shipping purposes only.

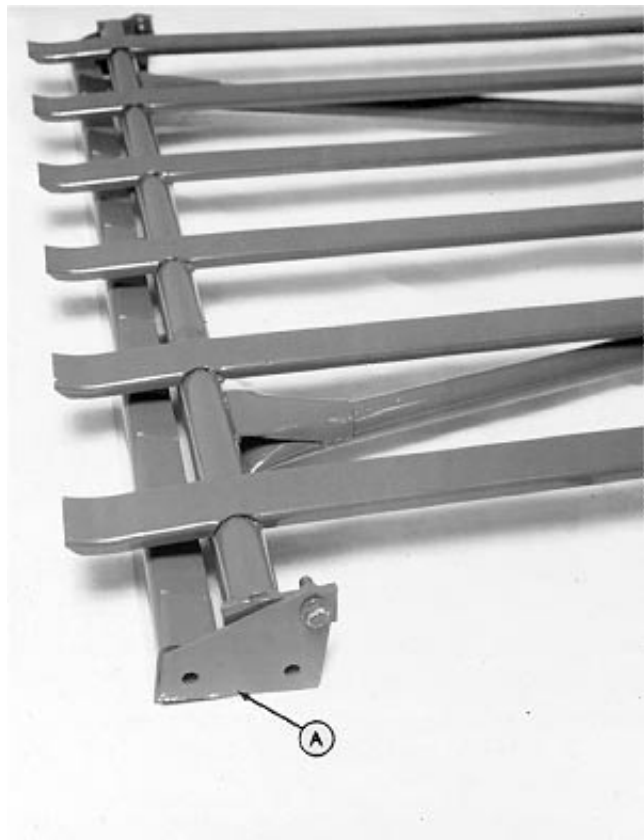

E34299 -UN-24JUL90

EX,435USR,U -19-24AUG90

Surface Wrap Assembly

3. Install belt guide (A). Fasten with four M10 x 40 flange screws (B).

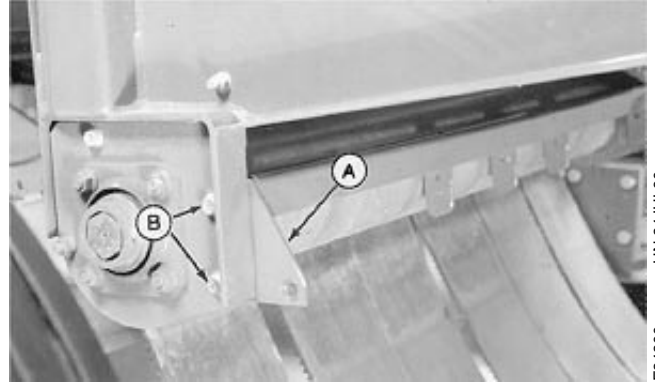

EX,435USR,V -19-14SEP90

E34300
-UN-24JUL90

NOTE: If optional Build-Up Reduction Scraper Kit is to be installed, refer to instruction in the bundle.

IMPORTANT: Inspect roll end play. Washers should be loose enough to turn by hand. End of roller must not contact bolt heads on either end with slack removed. Adjust roll position with washers, if necessary.

4. Reinstall scraper (A). Fasten with existing hardware. Adjust clearance between scraper and gate roller. (See Adjusting Lower Feed Roll Scraper in the Service section of baler operator's manual.)

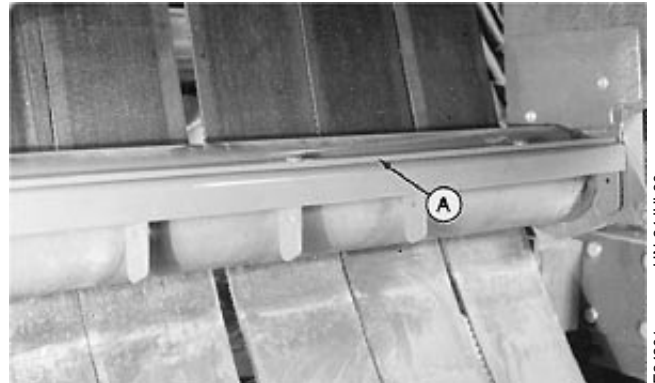

EX,435USR,AVA1 -19-25SEP95

E34301
-UN-24JUL90

INSTALL LOWER SURFACE WRAP GUIDE

1. Attach lower guide (A) to frame. Install M10 x 30 flange screws (B) through 3/8 x 3/8-in. spacers, lower guide, and frame. Fasten with 13/32 x 1 x 0.060-in. washers and flange nuts (C).

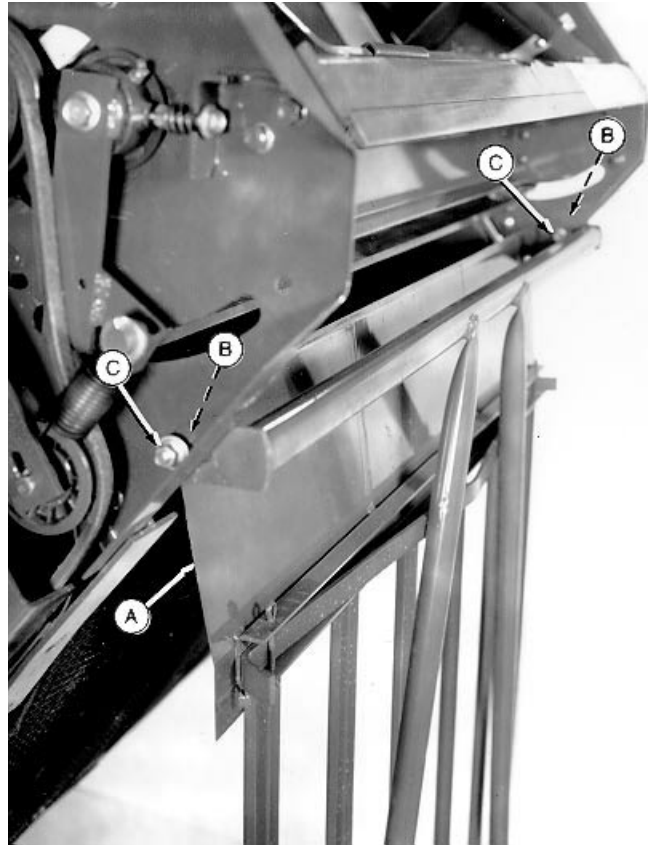

EX,435USR,W -19-22SEP95

E39508 -UN-26SEP95

2. Attach guide to lower belt guide with M12 x 25 cap screws and flange nuts (A).



EX,435USR,X -19-21JUN90

E34303 -UN-24JUL90

3. Check that belts are not pinched between lower belt guide straps (A) and cross tube.

4. Check for 2 to 4 mm (3/32 x 5/32-in.) gap between all belt guide straps (A) and top of cross tube. Adjust if necessary.

5. Unlock and close the gate.

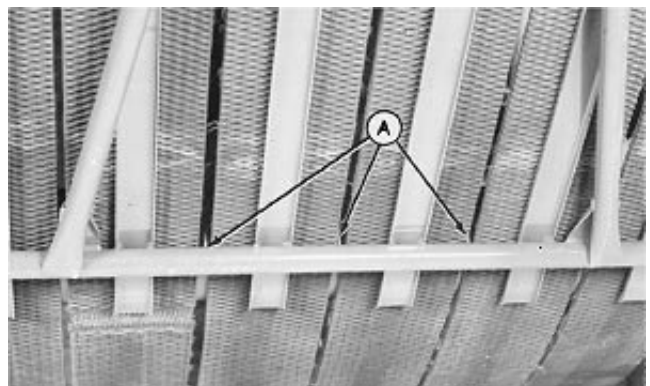

EX,435USR,Y -19-14SEP90

E34279 -UN-24JUL90

CHECK BELT TRACKING

IMPORTANT: Incorrect belt tracking can cause belt wear and damage to surface wrap.

Check belt tracking and adjust if necessary. (Refer to Checking Belt Tracking and Adjusting Belt Tracking in the Service section of the baler operator's manual.)

EX,435USR,AS -19-16JUL92

CHECK REAR PAN ADJUSTMENT

1. Check belt tracking before adjusting rear pan. Adjust if necessary.
2. Make sure left hand side of rear pan crosstube is in center of slot (A). This position never changes regardless of the position of the lower rear gate roller.

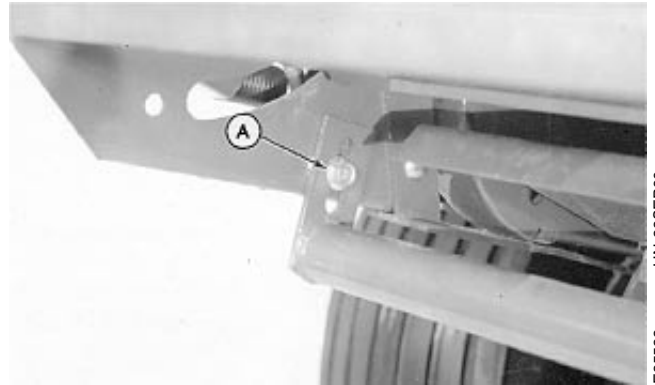

E35522
-UN-28SEP90

EX,435USR,Z -19-25SEP90

3. If lower rear gate roller is adjusted at the bottom of slot (A), adjust right hand side crosstube to lowest position (B), as shown.

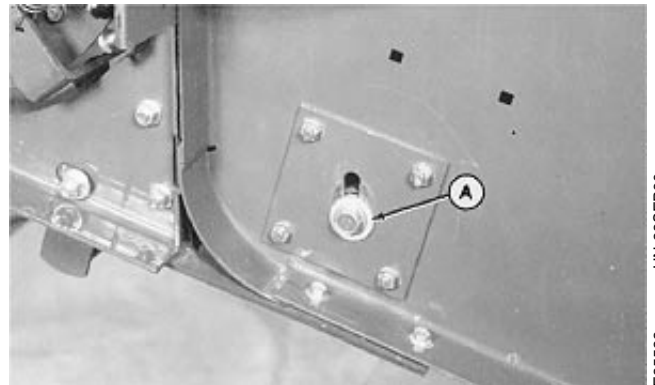

E35523
-UN-28SEP90

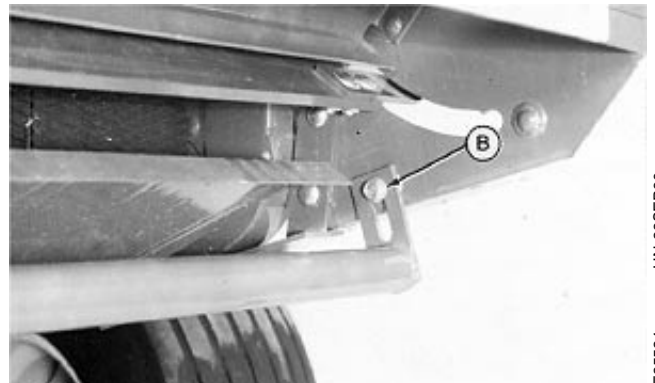

E35524
-UN-28SEP90

EX,435USR,AZA1 -19-25SEP95

Surface Wrap Assembly

4. If lower rear gate roller is adjusted at the center of slot (A), adjust right hand side crosstube to center position (B).

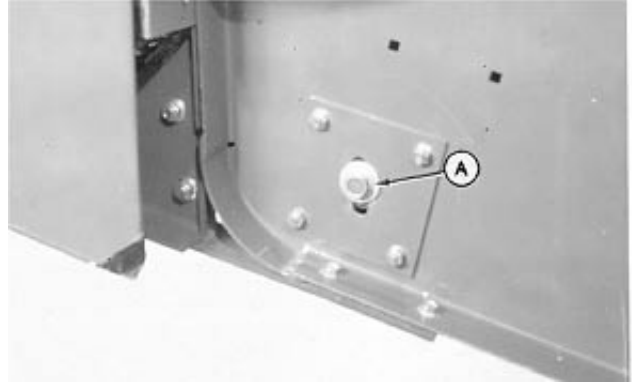

-UN-28SEP90

E35525

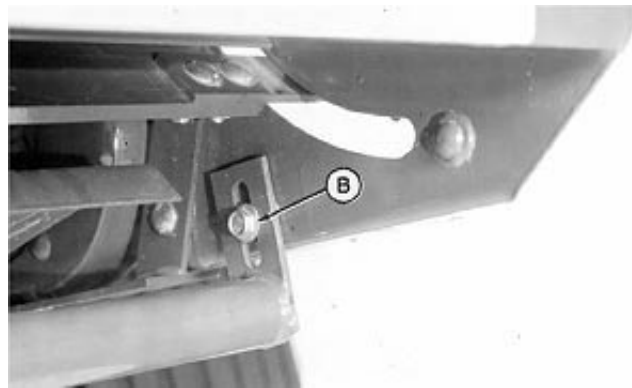

-UN-28SEP90

E35526

EX,435USR,BA -19-25SEP90

5. If lower rear gate roller is adjusted at the top of slot (A), adjust right hand side crosstube to highest position (B), as shown.

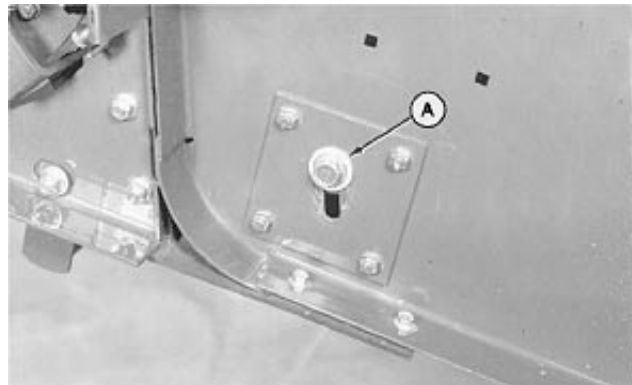

-UN-28SEP90

E35527

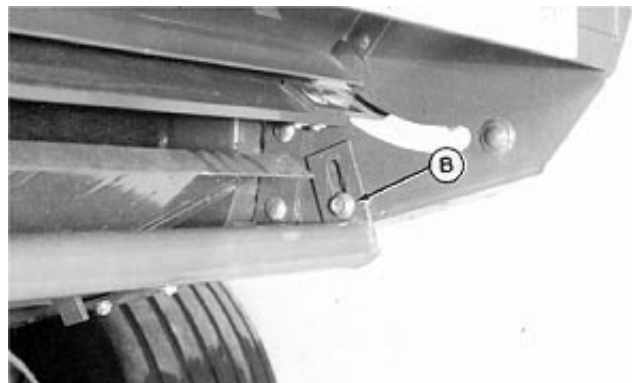

-UN-28SEP90

E35528

EX,435USR,BBA1 -19-25SEP95

REMOVE THREADED ORIFICE

IMPORTANT: Use a straight screwdriver big enough to fit the slots in the orifice, but small enough to avoid damaging the threads in the cylinder port.

NOTE: It is not necessary to remove twine arm cylinder when removing the orifice.

1. Remove orifice (A) from the head end of the twine arm cylinder (B).
2. Adjust twine arm speed to allow approximately two full wraps of surface wrap material. (See Adjusting Number of Surface Wraps on the Bale in Operating Baler with Surface Wrap section.)

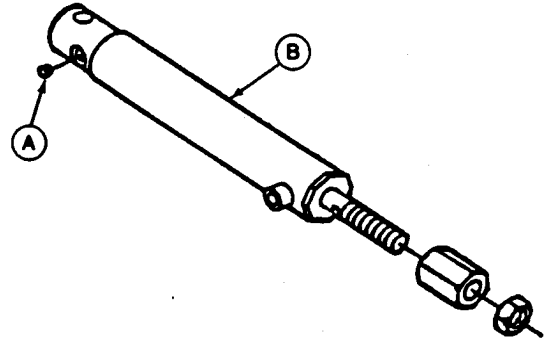

EX,435USR,BKA1 -19-25SEP95

-UN-22JUN92
E36887

ROUTING HYDRAULIC HOSES AND WIRING HARNESS

1. Install grommet (A) through hole.

IMPORTANT: Be sure to leave sufficient harness and hose slack at gate pivot.

2. Attach rear harness leads (B) to Common and Normally Closed switch terminals. Route harness along gate side and over gate pivot as shown on following page. Do not clamp at this time.
3. Connect front harness leads to oversize bale switch wire leads. (Refer to Key (F) illustrated on the following pages.)

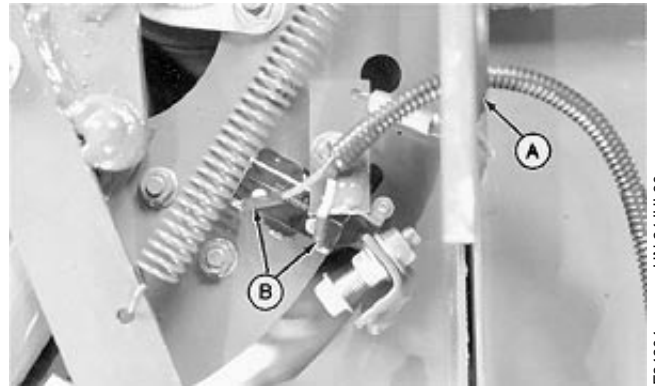

EX,435USR,AA -19-17JAN91

-UN-24JUL90
E34304

Surface Wrap Assembly

NOTE: Route one hose with large end fitting and one hose with small end fitting to the rear.

4. Blow air through hoses to remove contamination. Connect hydraulic hoses (A) on cylinder fittings.

5. Install clamps (B) as shown.

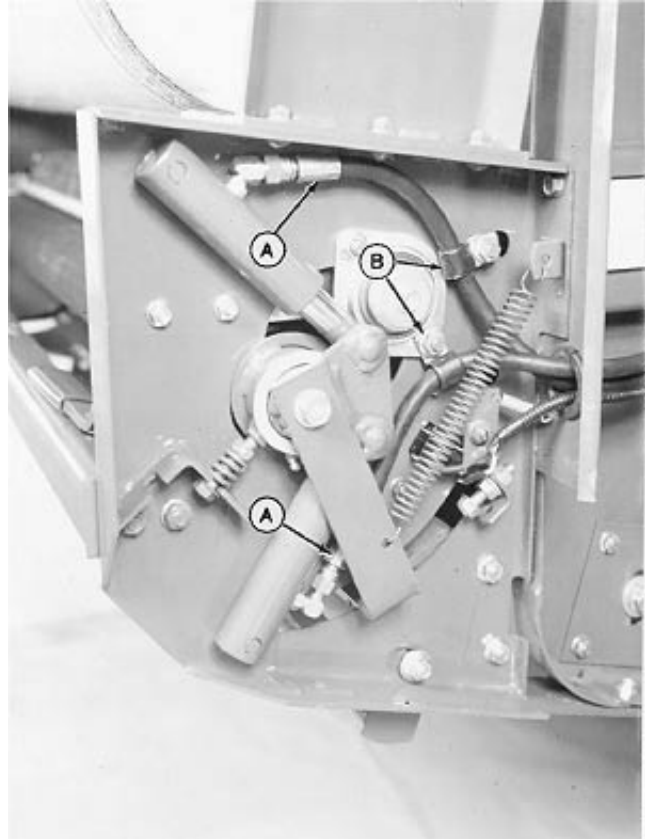

EX,435USR,AB -19-14SEP90

6. Route hoses through oval slots (A) in frame near the base of the tension hydraulic cylinder.

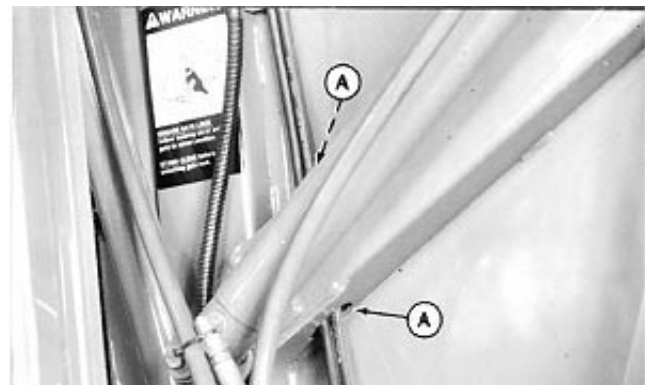

EX,435USR,BJ -19-25JUN92

Surface Wrap Assembly

Surface Wrap Assembly

7. Use 10 clamps (A) and 10 self-tapping screws (B) to secure hydraulic hoses (C) and wiring harness (D) on machine, as shown on opposite page. Clamp (G) already exists on machine. Use tie straps as necessary.

On front side of frame, position clamps on existing harness (H) outside clamps (A) as shown.

Use existing holes on the gate and front frame members.

A—Clamps
B—Self-Tapping Screws
C—Hydraulic Hoses

D—Wiring Harness
E—Surface Wrap Cutoff
Microswitch

F—Oversize Bale Microswitch **H—Existing Harness**
G—Clamp

Legend for Hoses and Harness Routing

EX,435USR,ACA1 -19-25SEP95

SURFACE WRAP HYDRAULIC HOSES AND WIRING HARNESS ROUTING

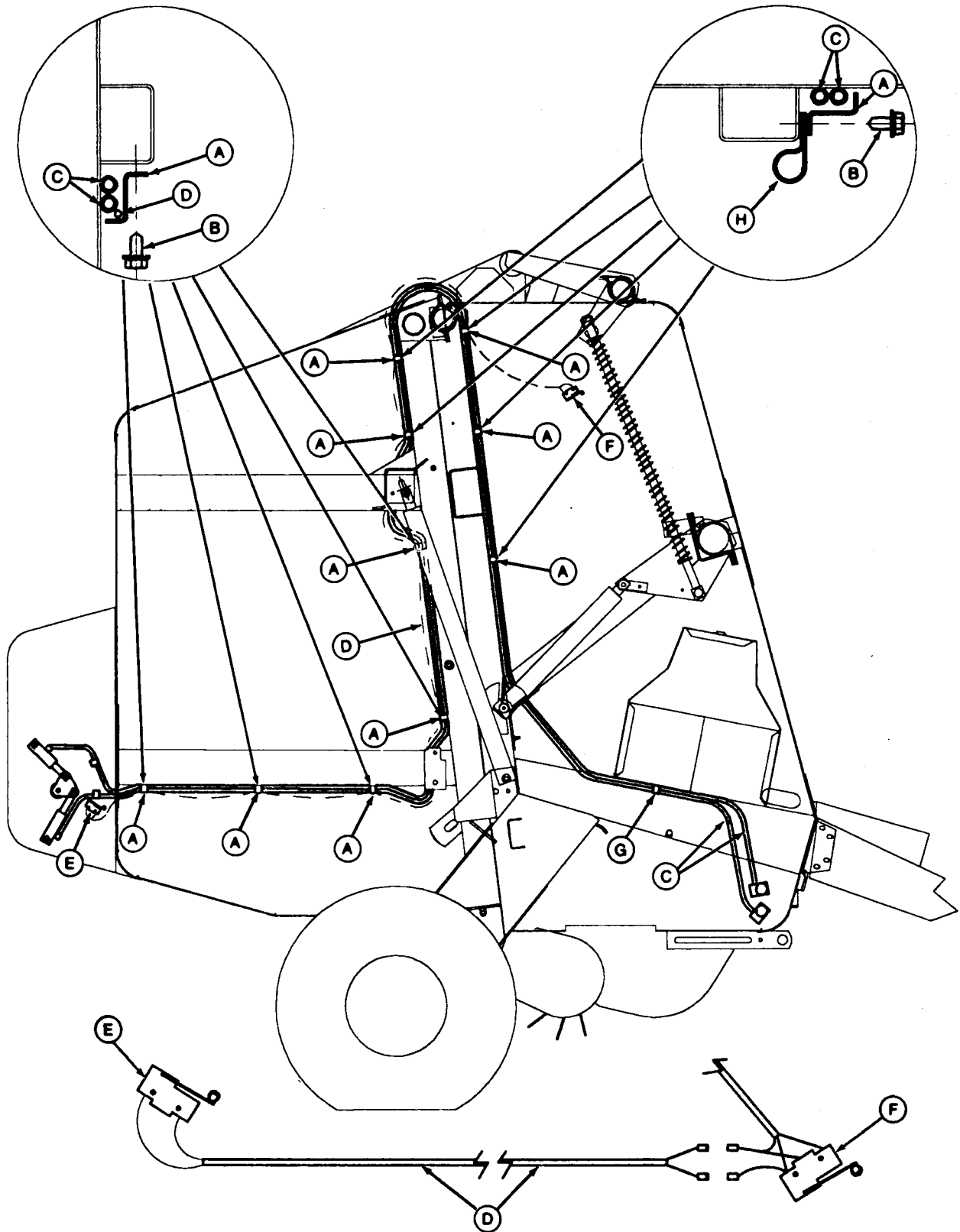

PROCEDURE FOR TWO SIDE-PORT TWINE WRAPPING VALVE

1. Disconnect hose (A) and remove adapter fitting.
2. Remove plug (B) from twine valve

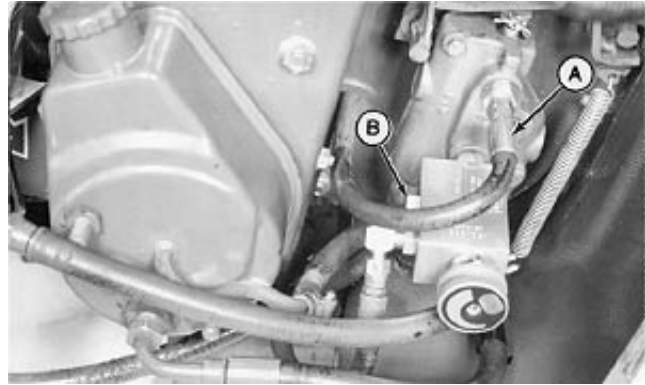

EX,435USR,AL -19-16JAN91

E34313 -UN-24JUL90

NOTE: Install new O-rings when installing O-ring adapter fittings.

3. Install union fitting (A) into new flow-control valve with loose nut (B) away from valve.
4. Remove plug (C).

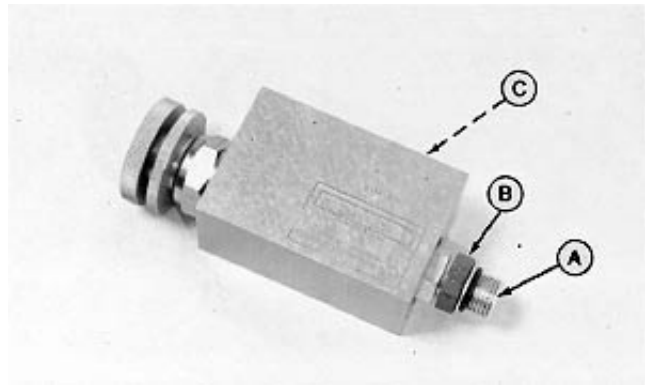

EX,435USR,AM -19-24JAN91

E34307 -UN-24JUL90

5. Install valve (A) into top port of twine spool valve. Position as shown.
6. Install pipe swivel elbow (B) in open port of original valve. Position with swivel elbow upward as shown. Tighten elbow nut.

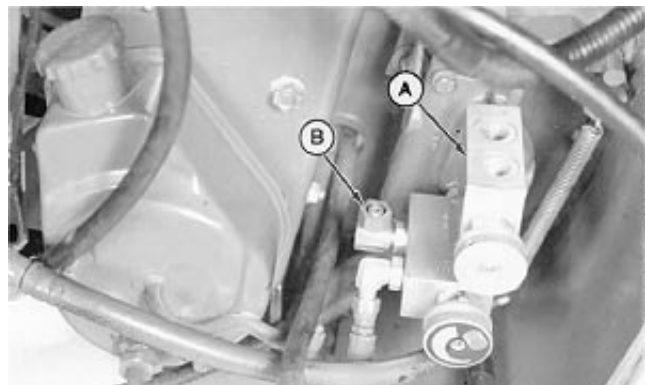

EX,435USR,AN -19-16JAN91

E34314 -UN-24JUL90

7. Install fitting (1/4 in. pipe nipple) (A) on shut-off valve. Install with internal chamfer (B) on exposed end.
8. Install fitting (1/4 in. pipe - 7/16 in. - 20 UNF - 37° flare) (C).

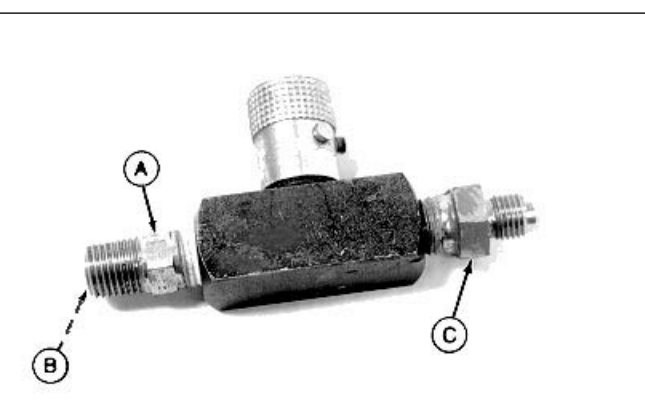

EX,435USR,AOA1 -19-25SEP95

E39507 -UN-22SEP95

Surface Wrap Assembly

9. Install shut-off valve (A). Position valve, as shown, for easy access. Tighten swivel nut.

10. Connect surface wrap hose (B).

11. Install adapter fitting (9/16-in. - 18 - O-ring - 9/16-in. - 18 - 37° flare) (C) into inboard port of new flow valve and connect surface wrap hose (D).

12. Tighten hoses.

- A—Shut-Off Valve
- B—Surface Wrap Hose
- C—Adapter Fitting (9/16-in. - 18 - O-ring - 9/16-in. - 18 - 37° flare)
- D—Surface Wrap Hose

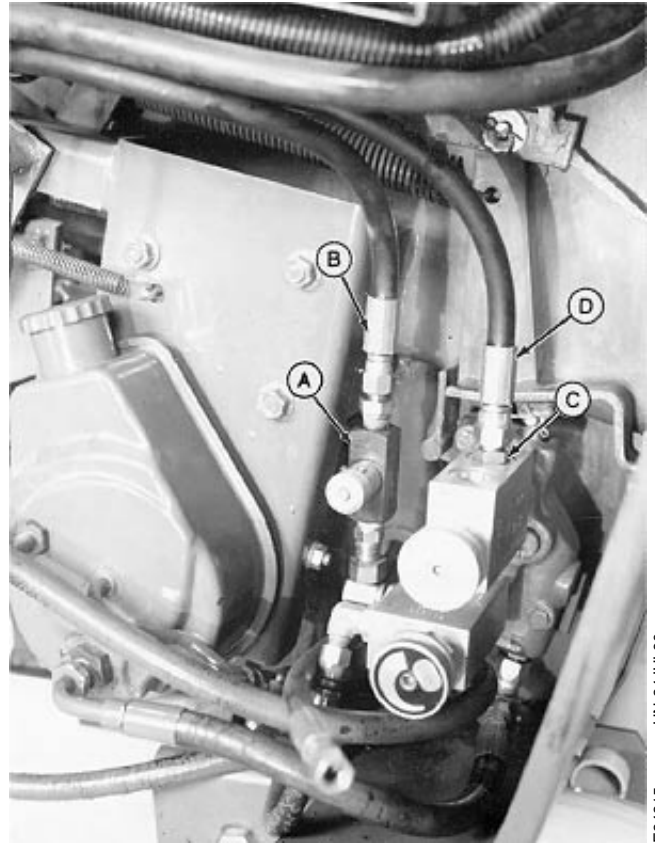

EX,435USR,AP -19-28JAN91

E34315
-UN-24JUL90

13. Install elbow fitting (7/16-in. - 20 - 37° flare) (A) and connect twine cylinder hose (B).

14. Clean control valve knob.

15. Install surface wrap decal (C).

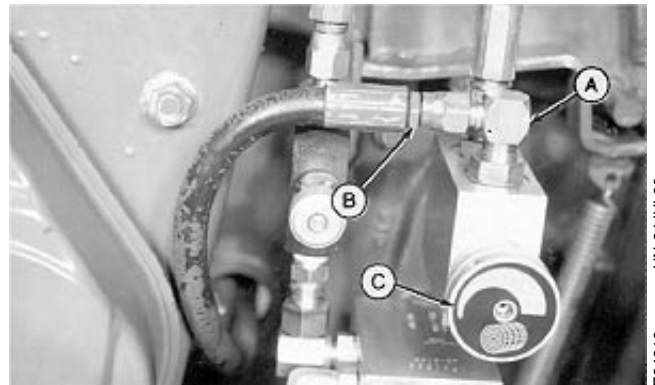

EX,435USR,AQ -19-24JAN91

E34316
-UN-24JUL90

CHECK OUT SURFACE WRAP SYSTEM

1. Check oil level in hydraulic pump.
2. Adjust flow-control knobs for surface wrap operation. (See Changing From Twine Wrap to Surface Wrap in Operating Baler with Surface Wrap section.)
3. Operate surface wrap system. (See Operating Surface Wrap System with Empty Baler in Operating Baler with Surface Wrap.)
4. Cycle surface wrap system a few times. Check hydraulic pump oil level.
5. If additional oil is required, recycle and recheck oil level in hydraulic pump.
6. Check belt tracking. (See Adjusting Belt Tracking in baler operator's manual.)

EX,435USR,BD -19-01MAR91

Specifications

RECORD PRODUCT IDENTIFICATION NUMBER

When ordering parts, always furnish model and serial number as given on serial number plate. It will assist your John Deere dealer in giving you prompt and efficient service.

The surface wrap serial number is located on the left-hand side of frame.

Record identification number in the space provided.



EX,435USS,AA1 -19-25SEP95

METRIC BOLT AND CAP SCREW TORQUE VALUES

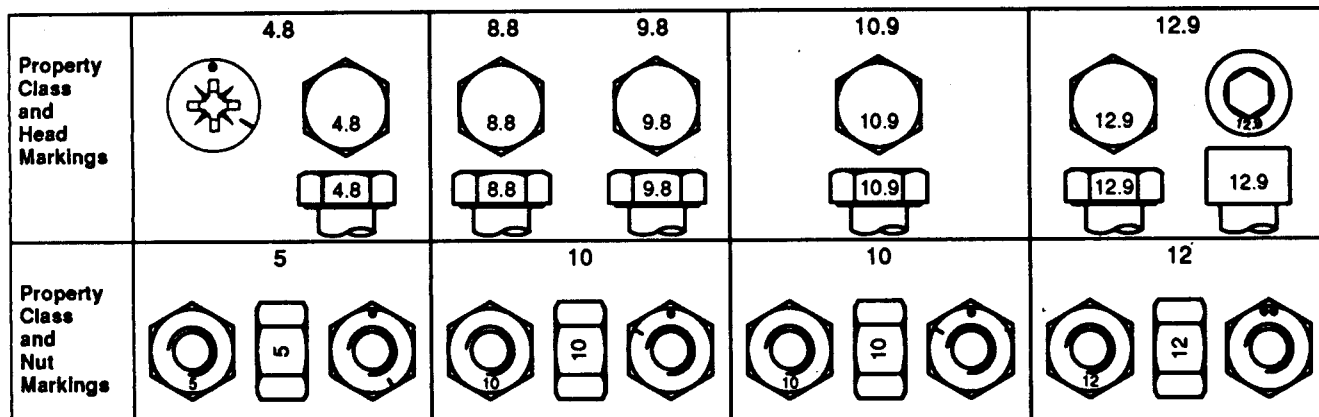

TS1163 -19-04MAR91

Size	Class 4.8				Class 8.8 or 9.8				Class 10.9				Class 12.9			
	Lubricated ^a		Dry ^a		Lubricated ^a		Dry ^a		Lubricated ^a		Dry ^a		Lubricated ^a		Dry ^a	
	N-m	lb-ft	N-m	lb-ft	N-m	lb-ft	N-m	lb-ft	N-m	lb-ft	N-m	lb-ft	N-m	lb-ft	N-m	lb-ft
M6	4.8	3.5	6	4.5	9	6.5	11	8.5	13	9.5	17	12	15	11.5	19	14.5
M8	12	8.5	15	11	22	16	28	20	32	24	40	30	37	28	47	35
M10	23	17	29	21	43	32	55	40	63	47	80	60	75	55	95	70
M12	40	29	50	37	75	55	95	70	110	80	140	105	130	95	165	120
M14	63	47	80	60	120	88	150	110	175	130	225	165	205	150	260	190
M16	100	73	125	92	190	140	240	175	275	200	350	255	320	240	400	300
M18	135	100	175	125	260	195	330	250	375	275	475	350	440	325	560	410
M20	190	140	240	180	375	275	475	350	530	400	675	500	625	460	800	580
M22	260	190	330	250	510	375	650	475	725	540	925	675	850	625	1075	800
M24	330	250	425	310	650	475	825	600	925	675	1150	850	1075	800	1350	1000
M27	490	360	625	450	950	700	1200	875	1350	1000	1700	1250	1600	1150	2000	1500
M30	675	490	850	625	1300	950	1650	1200	1850	1350	2300	1700	2150	1600	2700	2000
M33	900	675	1150	850	1750	1300	2200	1650	2500	1850	3150	2350	2900	2150	3700	2750
M36	1150	850	1450	1075	2250	1650	2850	2100	3200	2350	4050	3000	3750	2750	4750	3500

DO NOT use these values if a different torque value or tightening procedure is given for a specific application. Torque values listed are for general use only. Check tightness of fasteners periodically.

Shear bolts are designed to fail under predetermined loads. Always replace shear bolts with identical property class.









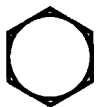

Fasteners should be replaced with the same or higher property class. If higher property class fasteners are used, these should only be tightened to the strength of the original.

Make sure fasteners threads are clean and that you properly start thread engagement. This will prevent them from failing when tightening.

Tighten plastic insert or crimped steel-type lock nuts to approximately 50 percent of the dry torque shown in the chart, applied to the nut, not to the bolt head. Tighten toothed or serrated-type lock nuts to the full torque value.

^a "Lubricated" means coated with a lubricant such as engine oil, or fasteners with phosphate and oil coatings. "Dry" means plain or zinc plated without any lubrication.

UNIFIED INCH BOLT AND CAP SCREW TORQUE VALUES

SAE Grade and Head Markings	1 or 2 ^b	5	5.1	5.2	8	8.2
	NO MARK 					
SAE Grade and Nut Markings	2	5		8		
	NO MARK 					

TS1162 -19-04MARG1

Size	Grade 1				Grade 2 ^b				Grade 5, 5.1, or 5.2				Grade 8 or 8.2			
	Lubricated ^a		Dry ^a		Lubricated ^a		Dry ^a		Lubricated ^a		Dry ^a		Lubricated ^a		Dry ^a	
	N-m	lb-ft	N-m	lb-ft	N-m	lb-ft	N-m	lb-ft	N-m	lb-ft	N-m	lb-ft	N-m	lb-ft	N-m	lb-ft
1/4	3.7	2.8	4.7	3.5	6	4.5	7.5	5.5	9.5	7	12	9	13.5	10	17	12.5
5/16	7.7	5.5	10	7	12	9	15	11	20	15	25	18	28	21	35	26
3/8	14	10	17	13	22	16	27	20	35	26	44	33	50	36	63	46
7/16	22	16	28	20	35	26	44	32	55	41	70	52	80	58	100	75
1/2	33	25	42	31	53	39	67	50	85	63	110	80	120	90	150	115
9/16	48	36	60	45	75	56	95	70	125	90	155	115	175	130	225	160
5/8	67	50	85	62	105	78	135	100	170	125	215	160	240	175	300	225
3/4	120	87	150	110	190	140	240	175	300	225	375	280	425	310	550	400
7/8	190	140	240	175	190	140	240	175	490	360	625	450	700	500	875	650
1	290	210	360	270	290	210	360	270	725	540	925	675	1050	750	1300	975
1-1/8	400	300	510	375	400	300	510	375	900	675	1150	850	1450	1075	1850	1350
1-1/4	570	425	725	530	570	425	725	530	1300	950	1650	1200	2050	1500	2600	1950
1-3/8	750	550	950	700	750	550	950	700	1700	1250	2150	1550	2700	2000	3400	2550
1-1/2	1000	725	1250	925	990	725	1250	930	2250	1650	2850	2100	3600	2650	4550	3350

DO NOT use these values if a different torque value or tightening procedure is given for a specific application. Torque values listed are for general use only. Check tightness of fasteners periodically.

Fasteners should be replaced with the same or higher grade. If higher grade fasteners are used, these should only be tightened to the strength of the original.

Shear bolts are designed to fail under predetermined loads. Always replace shear bolts with identical grade.

Make sure fasteners threads are clean and that you properly start thread engagement. This will prevent them from failing when tightening.

Tighten plastic insert or crimped steel-type lock nuts to approximately 50 percent of the dry torque shown in the chart, applied to the nut, not to the bolt head. Tighten toothed or serrated-type lock nuts to the full torque value.

^a "Lubricated" means coated with a lubricant such as engine oil, or fasteners with phosphate and oil coatings. "Dry" means plain or zinc plated without any lubrication.

^b Grade 2 applies for hex cap screws (not hex bolts) up to 152 mm (6-in.) long. Grade 1 applies for hex cap screws over 152 mm (6-in.) long, and for all other types of bolts and screws of any length.

Index

Page

Page

A

Additional Storage For Surface Wrap	6
Adjusting Feed Roll Pressure	31
Adjusting Knife Arm Stop	39
Adjusting Microswitch	36
Adjusting Number of Surface Wraps on the Bale	15
Adjusting Roll Support Brackets	38

B

BALE-TRAK Monitor Operation with Surface Wrap	13
Bale, Discharging, With Surface Wrap	13
Belt, Installing	33
Belt, Removing	33
Brackets For Surface Wrap Storage	6
Brake Bar Tension	
Decreasing	42
Increasing	41
Brake, Checking	35

C

Care of Surface Wrap	6
Changing From Surface Wrap To Twine Wrap	16
Changing From Twine Wrap To Surface Wrap	14
Checking Brake	35
Checking Drive Idler Adjustment	32

D

Diagram Hydraulic System Surface Wrapping	45
Discharging Bale With Surface Wrap	13
Drive Idler Adjustment, Checking	32

F

Feed Roll Pressure, Adjusting	31
Feed Rollers, Removing Wrappage From	36
Front Gate Roll, Servicing Lower	43

G

Gate Roll, Servicing Lower Front	43
General Information	10
Grease	
Extreme pressure and multipurpose	19

H

How The Surface Wrap Attachment Works	10
Hydraulic System, Surface Wrapping	45

I

Idler Adjustment, Checking Drive	32
Idler Arm, Removing V-Belt	34
Inch torque values	75
Installing Belt	33
Installing Knife	34

K

Knife Arm Stop, Adjusting	39
Knife Arm, Releasing Manually	18
Knife, Removing and Installing	34

L

Lower Front Gate Roll, Servicing	43
Lubricant	
Alternative	19
Synthetic	19
Lubrication, Annually	21
Lubrication, Every 30 Hours	20

M

Material, Selecting Surface Wrap	6
Metric torque values	74
Microswitch, Adjusting	36
Monitor, BALE-TRAK, Operation with Surface Wrap	13

O

Opening and Closing Surface Wrap Cover	7
---	---

Index

	Page		Page
Operating Surface Wrap System With		Torque values	
Empty Baler	17	Inch	75
Orifice, Twine Arm Cylinder		Metric	74
Remove	65	Twine Wrap to Surface Wrap, Changing	14
P			
Practice Safety	31		
Product identification number	73		
R			
Releasing Knife Arm Manually	18		
Removing and Installing Knife	34		
Removing Belt	33		
Removing V-Belt Idler Arm	34		
Removing Wrappage From Feed Rollers	36		
Roll Support Brackets, Adjusting	38		
Rollers, Removing Wrappage From Feed	36		
S			
Safety, Practice	31		
Serial number	73		
Servicing Lower Front Gate Roll	43		
Storage, Additional, For Surface Wrap	6		
Storage, Surface Wrap, Using after	11		
Support Brackets, Adjusting Roll	38		
Surface Wrap Attachment	10		
Surface Wrap Cover, Opening and			
Closing	7		
Surface Wrap Material, Selecting	6		
Surface Wrap Protection	6		
Surface Wrap System, Operating With			
Empty Baler	17		
Surface Wrap, Changing from Twine			
Wrap To	14		
Surface Wrap, Changing To Twine Wrap	16		
Surface Wrap, Threading and Routing	7		
Surface Wrap, Using after Storage	11		
Surface Wrapping Hydraulic System	45		
Surface Wraps, Adjusting Number of, on			
the Bale	15		
Synthetic Lubricants	19		
T			
Threading Surface Wrap	7		
Threading Surface Wrap Through Rolls	7		

John Deere Service Literature Available

PARTS CATALOG

The parts catalog lists service parts available for your machine with exploded view illustrations to help you identify the correct parts. It is also useful in assembling and disassembling.



DX,PARTS -19-03MAR93

TS189
-UN-17JAN89

OPERATOR'S MANUAL

The operator's manual provides safety, operating, maintenance, and service information about John Deere machines.

An extra copy of the operator's manual is available. The operator's manual and safety signs on your machine may also be available in other languages. (See your John Deere dealer to order.)



DX,OM -19-03MAR93

TS190
-UN-17JAN89

TECHNICAL AND SERVICE MANUALS

Technical and service manuals are service guides for your machine. Included in the manual are specifications, diagnosis, and adjustments. Also illustrations of assembly and disassembly procedures, hydraulic oil flows, and wiring diagrams.

Component technical manuals are required for some products. These supplemental manuals cover specific components.



DX,TM -19-03MAR93

TS224
-UN-17JAN89

JOHN DEERE PUBLISHING BOOKS

Covering all types of vehicles, regardless of manufacturer, each book starts with basic theory and proceeds through complex systems. There are four series:

- Farm Business Management (FBM)
- Fundamentals of Machine Operation (FMO)
- Fundamentals of Service (FOS)
- Fundamentals of Compact Equipment Service (FCP)



TS1646 -UN-02OCT95

DX,FMOFOS -19-02OCT95

John Deere Service Literature Available

John Deere Distribution Service Center
 Service Publications Department
 P.O. Box 186, Moline, IL. 61266-0186

Name _____

Address _____

To order, fill out this form and mail it to the address above. Check for prices with your John Deere dealer or call **1-800-522-7448**. You may also place credit card orders by calling this number. Make checks payable to Deere & Co. Service Publications. Allow three weeks for delivery. No COD orders. Do not send cash or stamps. If you want manuals or catalogs for equipment not shown on this list, provide the model number, serial number, and name of the product.

Title	Order Number	Price Each	x Quantity	= Total
Surface Wrap for 435 And 535 Round Balers				
Parts Catalog	PC2275		x	=
Operator's Manual	OME87620		x	=
Technical Manual	TM1472		x	=
			x	=
			x	=
			x	=
			x	=
			x	=
			x	=
			x	=
			x	=
			x	=
FMO Manual—Tractors	FMO10103BX		x	=
FMO Manual—Tillage	FMO11103B		x	=
FMO Manual—Planting	FMO12103B		x	=
FMO Manual—Hay & Forage Harvesting	FMO14104B		x	=
FMO Manual—Combine Harvesting	FMO15104B		x	=
FMO Manual—Preventive Maintenance	FMO16105B		x	=
FOS Manual—Hydraulics	FOS1005B		x	=
FOS Manual—Electronic and Electrical Systems	FOS2007B		x	=
FOS Manual—Engines	FOS3007B		x	=
FOS Manual—Power Trains	FOS4006B		x	=
FOS Manual—Welding	FOS5207B		x	=
FOS Manual—Belts and Chains	FOS5305B		x	=
FOS Manual—Bearings and Seals	FOS5405B		x	=
FOS Manual—Tires and Tracks	FOS5507B		x	=
FOS Manual—Mowers and Sprayers	FOS5605B		x	=
FOS Manual—Air Conditioning	FOS5708B		x	=
FOS Manual—Fuels, Lubricants & Coolants	FOS5807B		x	=
FMO Manual—Machinery Maintenance	FMW10103B		x	=
FBM Manual—Farm & Ranch Business Managmt.	FBM10103B		x	=
FBM Manual—Farm & Ranch Safety Management	FBM18104B		x	=
FBM Manual—Machinery Management	FBM17104B		x	=
FBM Manual—Chemical Applications Management	FBM19103B		x	=
1-in. 3-Ring Binder (400 pages max.)	SX2062		x	=
1-1/2-in. 3-Ring Binder (600 pages max.)	SX2063		x	=
1—1-1/2-in. 3-Post Binder (600 pages max.)	SX2066		x	=
2—3-1/2-in. 3-Post Binder (1400 pages max.)	SX2064		x	=
2—4-in. 4-Post Expandable (2000 pages max.)	SX2056		x	=
Catalog of Available Service Publications	DB1112	No Charge		
		Subtotal		

Method of Payment

Check or Money Order enclosed

John Deere Farm Plan

MasterCard Discover

Visa American Express

Credit Card Acct. No. (13 or 16 digits)

Expiration date: _____

Your Signature

Subtotal

\$ 0.50 to \$ 24.99 . . . \$ 3.50

25.00 to 49.99 5.00

50.00 to 99.99 6.50

100.00 to 199.99 9.00

200.00 and over . . . 4.5% of subtotal

Optional shipping available. Please check and add cost to normal shipping above.

1 day air \$15.00

2 day air \$10.00

Shipping & Handling

Illinois state residents add 6.25% and Iowa state residents add 5% for Retail Occupation Tax or show tax exemption number. Other states excluded.

Total Shipping & Handling

Amount Due in U.S. Dollars (Prices subject to change without notice. SEP-95)

EX,435US,SLITA -19-25SEP95

John Deere Service Keeps You On The Job

JOHN DEERE IS AT YOUR SERVICE WHEN YOU NEED IT

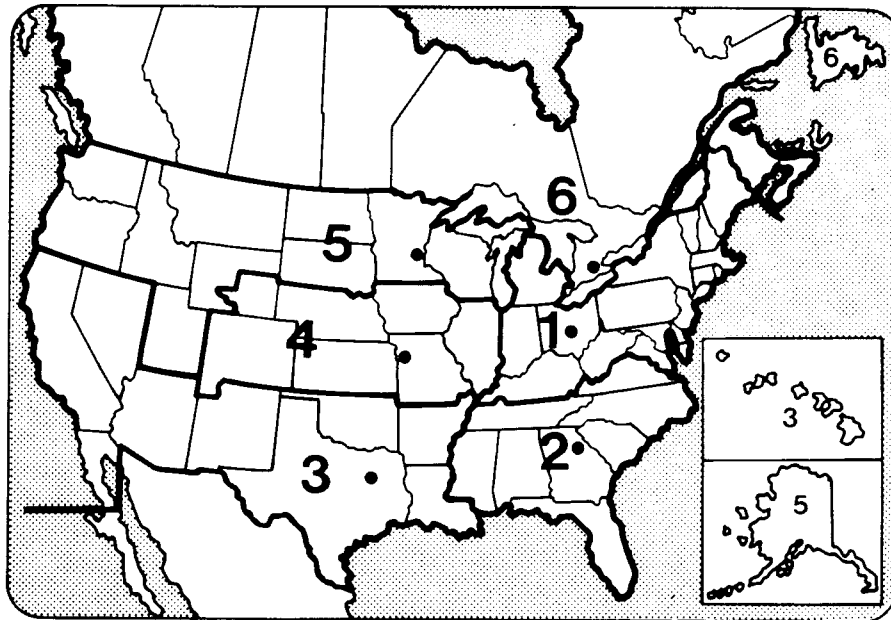

1. JOHN DEERE COMPANY
701 Georgesville Road
Columbus, OH 43228-2499
614-275-1500 (Fax. 614-275-1450)

3. JOHN DEERE COMPANY
P.O. Box 540598
Dallas, TX 75354-0598
214-385-1701 (Fax. 214-663-2390)

5. JOHN DEERE COMPANY
2001 West 94th Street
Bloomington, MN 55431-3211
612-887-6200 (Fax. 612-887-6385)

2. JOHN DEERE COMPANY
2001 Deere Dr.
Conyers, GA 30208
404-922-7040 (Fax. 404-388-2138)

4. JOHN DEERE COMPANY
3210 East 85th Street
Southeast Station
Kansas City, MO 64132-2586
816-361-4000 (Fax. 816-995-9381)

6. JOHN DEERE LIMITED
South Service Road at Hunter
Grimsby, Ontario, Canada L3M 4H5
905-945-9281 (Fax. 905-945-0341)

CUSTOMER SATISFACTION is important to John Deere. We take pride in providing superior service. We'll be around when you need us:

- We maintain a large and varied parts inventory to help minimize downtime.
- Precision tools and testing equipment enable technicians to locate and correct troubles.
- We hold regular training schools for service technicians so they know your equipment and how to maintain it.
- Our goal is to provide prompt, efficient service through competent dealerships.

COMPLAINT-RESOLUTION PROCEDURE

Your dealer is the best and fastest source to solving any problems you may experience with your product.

1. Be prepared with the following information:
 - Machine model and product identification number
 - Date of purchase
 - Nature of problem
2. Discuss problem with dealer service manager.
3. If unable to resolve, see the dealership manager. Explain the problem and request assistance.
4. If you have a persistent problem your dealership is unable to satisfy, ask your dealer to contact the John Deere territory aftermarket manager for resolution.
5. If a problem is not resolved to your satisfaction, contact the appropriate John Deere sales branch for your area and ask to speak with the division aftermarket manager. (See map.)

