



42 Bale Ejector



JOHN DEERE

OPERATORS MANUAL 42 Bale Ejector

OME83029 Issue K4 English

John Deere Ottumwa Works
OME83029 Issue K4

LITHO IN U.S.A.
ENGLISH



Introduction

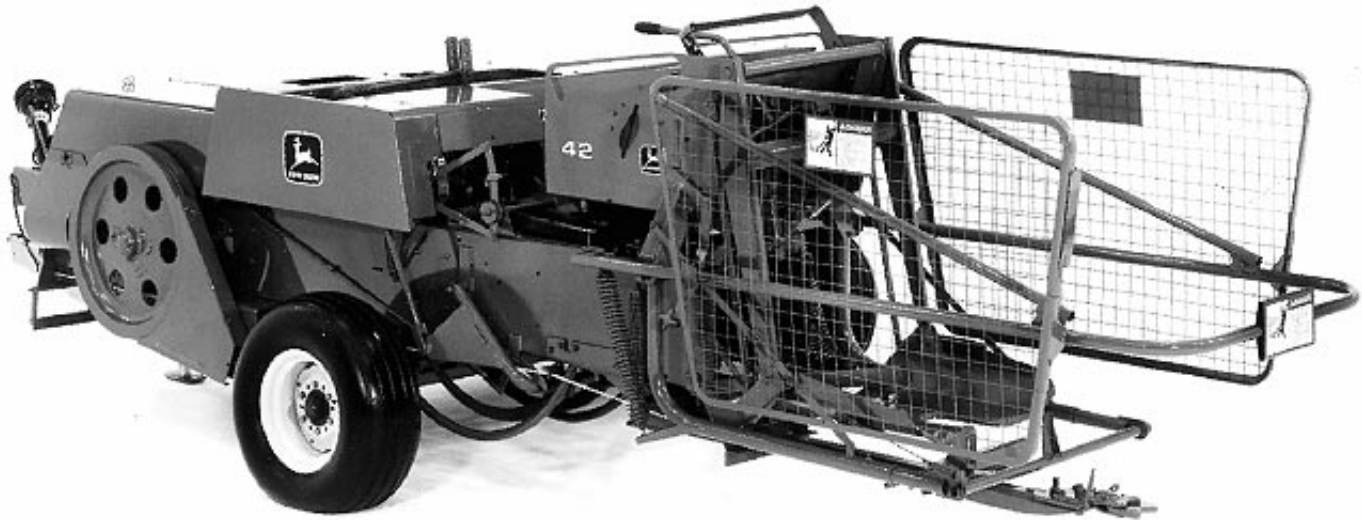

42 Bale Ejector on 338 Baler

READ THIS MANUAL carefully to learn how to operate and service your machine correctly. Failure to do so could result in personal injury or equipment damage. This manual and safety signs on your machine may also be available in other languages. (See your John Deere dealer to order.)

THIS MANUAL SHOULD BE CONSIDERED a permanent part of your machine and should remain with the machine when you sell it.

MEASUREMENTS in this manual are given in both metric and customary U.S. unit equivalents. Use only correct replacement parts and fasteners. Metric and inch fasteners may require a specific metric or inch wrench.

RIGHT-HAND AND LEFT-HAND sides are determined by facing in the direction the implement will travel when going forward.

WRITE PRODUCT IDENTIFICATION NUMBERS (P.I.N.) in the Specification section. Accurately record all the numbers to help in tracing the machine should

it be stolen. Your dealer also needs these numbers when you order parts. File the identification numbers in a secure place off the machine.

WARRANTY is provided as part of John Deere's support program for customers who operate and maintain their equipment as described in this manual. The warranty is explained on the warranty certificate which you should have received from your dealer.

This warranty provides you the assurance that John Deere will back its products where defects appear within the warranty period. In some circumstances, John Deere also provides field improvements, often without charge to the customer, even if the product is out of warranty. Should the equipment be abused, or modified to change its performance beyond the original factory specifications, the warranty will become void and field improvements may be denied. Setting fuel delivery above specifications or otherwise overpowering machines will result in such action.

THE TIRE MANUFACTURER'S warranty applicable to your machine may not apply outside the U.S.

-JUN-01/JUN94
E38170

42 Bale Ejector Checklists

DEALER'S RECORD

Owner's Name _____ Date Sold _____
Address _____ Model Number _____
City _____ Serial Number _____
State _____ Zip _____

OME,42BE,CLIS,A-19-26OCT94

PREDELIVERY CHECKLIST

Assemble machine and inspect it for good running condition before delivering. Use the following checklist:

- Machine lubricated. (See Lubrication section.)
- All moving parts work freely.
- Hydraulic cylinders operate properly.
- Hydraulic hoses properly routed and clamped.
- Hydraulic reservoir filled to check plug level.
- Pump drive belt adjusted to correct dimension.
- Relief valve properly adjusted.
- Hand trip lever adjusted properly.
- Console control (optional) properly attached in tractor and functioning correctly.
- Electric distance control functions properly.
- Electric tilt motor (optional) functions properly.
- Automatic wagon disconnect (optional) functions properly.
- Bale case measuring arm is adjusted correctly for bale ejector.
- Electrical wiring correctly routed and clamped to avoid pinch points, kinks and sharp edges.
- All operating adjustments have been made.

(Date Set Up)

(Signature of Set-Up Technician)

OME,42BE,CLIS,B-19-26OCT94

DELIVERY CHECKLIST

Convey the following important information to the customer at the time machine is delivered.

- Advise the customer that the life expectancy of this machine is dependent on regular lubrication as described in operator's manual.
- Advise customer of safety precautions that must be observed while using this machine (See Safety section.)
- Give the operator's manual to customer and explain all operating adjustments and lubrication.
- Point out safety lockout and correct use.

- When the machine is transported on a road or highway, accessory lights and devices should be used for adequate warning to operators of other vehicles. In this regard, tell customer to check local governmental regulations. Among these is the SMV (slow-moving vehicle) emblem which can be attached vertically to the mounting on the front side of the left-hand spring support bracket to provide proper light reflection.
- Advise the customer of optional attachments that are available for special crop and operating conditions.
- Explain the operation of console controls.

(Date Delivered)

(Signature)

OME,42BE,CLIS,C-19-26OCT94

AFTER-SALE CHECKLIST

It is suggested the following items be checked sometime during the first season's operation.

- Check for broken or damaged parts.
- If possible, run the machine to see if it is functioning properly.
- Go over machine and check for loose parts or missing bolts.

- Check pump drive belt for proper tension.
- Review operator's manual with customer and stress the importance of proper and regular lubrication and safety precautions.

(Signature)

(Date Checked)

OME,42BE,CLIS,D-19-26OCT94

Contents

	Page		Page
Safety	1	Hydraulic System Diagram	43
Preparing the Bale Ejector	9	Storage	44
Transporting	11	Assembly	
Operating the Bale Ejector		Install	
Baling with Bale Ejector	13	Wheel Extensions	46
Ejecting Bales	13	Bale Ejector Assembly	46
Bale Size	13	Hydraulic Pump Assembly	58
Using Electric Controls	14	Hydraulic Tilt Cylinder	60
Using Side Screens	15	Short Hose Extensions	63
Using Hand Trip Lever	16	Electric Controls—Tilt Actuator	63
Adjusting Bale Length Timing	16	Wagon Hitch Release	68
Throwing Frame Latch	18	Specifications	71
Adjusting Bale Weight	19	Crime Prevention Tips	74
Adjusting Bale Length	19	Index	
Using Optional Hydraulic Aiming Control	20		
Dropping Bales on the Ground	20		
Adjusting Bale Case Extensions	21		
Attachments	22		
Lubrication and Maintenance	24		
Troubleshooting			
Troubleshooting			
Miscellaneous	31		
Hydraulic Pump	32		
Latch and Throwing Cylinder	34		
Control Valve	35		
Electrical	36		
Service			
Practice Safety	38		
Adjusting Trip Cam	38		
Adjusting Trip Cable	39		
Changing Hydraulic Oil	40		
Adjusting Pump Drive Belt	41		
Adjusting Latch Springs	41		
Wiring Diagram	42		

All information, illustrations and specifications in this manual are based on the latest information available at the time of publication. The right is reserved to make changes at any time without notice.

OME83029 K4-19-21OCT94

COPYRIGHT© 1994
DEERE & COMPANY
Moline, Illinois
All rights reserved
A John Deere ILLUSTRATION® Manual

Contents

Safety

RECOGNIZE SAFETY INFORMATION

This is the safety-alert symbol. When you see this symbol on your machine or in this manual, be alert to the potential for personal injury.

Follow recommended precautions and safe operating practices.

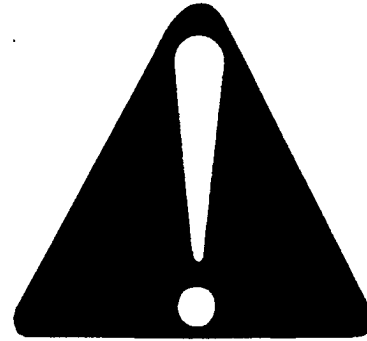

DX,ALERT -19-03MAR93

T81389 -UN-07DEC88

UNDERSTAND SIGNAL WORDS

A signal word—DANGER, WARNING, or CAUTION—is used with the safety-alert symbol. DANGER identifies the most serious hazards.

DANGER or WARNING safety signs are located near specific hazards. General precautions are listed on CAUTION safety signs. CAUTION also calls attention to safety messages in this manual.



DX,SIGNAL -19-03MAR93

TS187 -19-30SEP88

FOLLOW SAFETY INSTRUCTIONS

Carefully read all safety messages in this manual and on your machine safety signs. Keep safety signs in good condition. Replace missing or damaged safety signs. Be sure new equipment components and repair parts include the current safety signs. Replacement safety signs are available from your John Deere dealer.

Learn how to operate the machine and how to use controls properly. Do not let anyone operate without instruction.

Keep your machine in proper working condition. Unauthorized modifications to the machine may impair the function and/or safety and affect machine life.

If you do not understand any part of this manual and need assistance, contact your John Deere dealer.

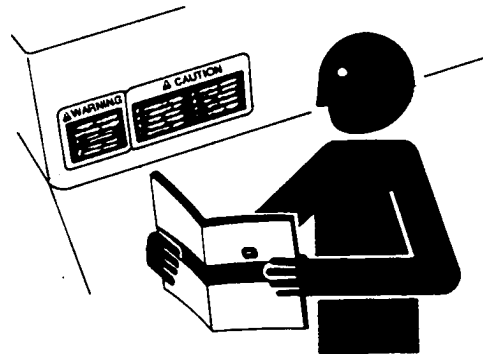

DX,READ -19-03MAR93

TS201 -UN-23AUG88



OPERATE SAFELY

Keep all shields in place while operating.

Keep hands, feet, and clothing away from moving parts.

Never stand behind ejector while baler is operating.

Do not use a chuck or forage wagon for loading or transporting bales.

Do not attempt to pull bales from ejector while baler is operating.

Never attempt to unplug ejector unless lockout is engaged.

Before servicing, adjusting, removing bales or other material from ejector, or hitching wagon to baler:

1. Disengage all power.
2. Shut off tractor engine.
3. Wait until baler flywheel has stopped turning.
4. Move lockout lever to locked position.



E37067 -UN-15FEB93

OME,42BE,SAF,A -19-26OCT94

KEEP RIDERS OFF MACHINE

Only allow the operator on the machine. Keep riders off.

Riders on machine are subject to injury such as being struck by foreign objects and being thrown off of the machine. Riders also obstruct the operator's view resulting in the machine being operated in an unsafe manner.

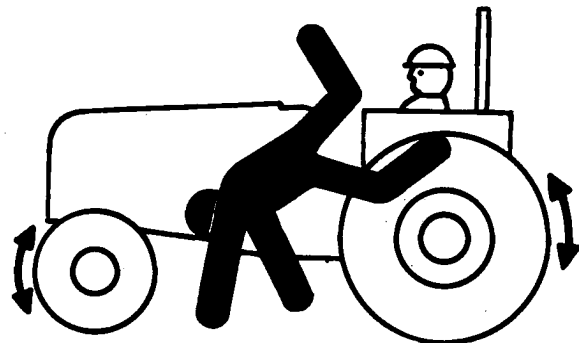

TS290 -UN-23AUG88

DX,RIDER -19-03MAR93



PREPARE FOR EMERGENCIES

Be prepared if a fire starts.

Keep a first aid kit and fire extinguisher handy.

Keep emergency numbers for doctors, ambulance service, hospital, and fire department near your telephone.

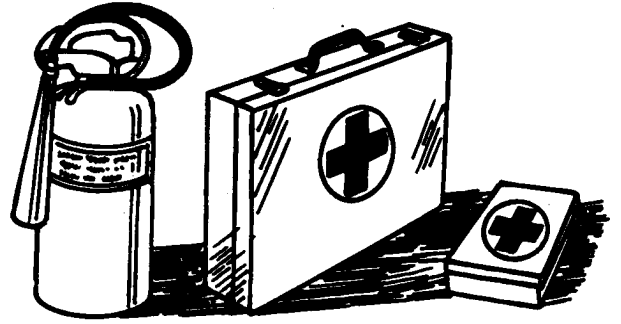

DX,FIRE2 -19-03MAR93

TS291 -UN-23AUG88

WEAR PROTECTIVE CLOTHING

Wear close fitting clothing and safety equipment appropriate to the job.

Prolonged exposure to loud noise can cause impairment or loss of hearing.

Wear a suitable hearing protective device such as earmuffs or earplugs to protect against objectionable or uncomfortable loud noises.

Operating equipment safely requires the full attention of the operator. Do not wear radio or music headphones while operating machine.

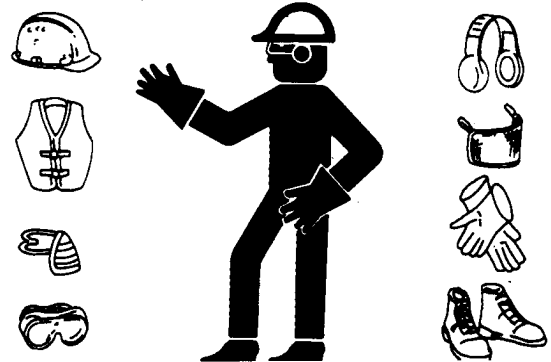

DX,WEAR -19-10SEP90

TS206 -UN-23AUG88



HANDLE CHEMICAL PRODUCTS SAFELY

Direct exposure to hazardous chemicals can cause serious injury. Potentially hazardous chemicals used with John Deere equipment include such items as lubricants, coolants, paints, and adhesives.

A Material Safety Data Sheet (MSDS) provides specific details on chemical products: physical and health hazards, safety procedures, and emergency response techniques.

Check the MSDS before you start any job using a hazardous chemical. That way you will know exactly what the risks are and how to do the job safely. Then follow procedures and recommended equipment.

(See your John Deere dealer for MSDS's on chemical products used with John Deere equipment.)



DX,MSDS,NA -19-03MAR93

TS1132 -UN-26NOV90

USE SAFETY LIGHTS AND DEVICES

Slow moving tractors, self-propelled equipment and towed implements or attachments can create a hazard when driven on public roads. They are difficult to see, especially at night. Avoid personal injury or death resulting from collision with a vehicle.

Whenever driving on public roads, use flashing warning lights and turn signal according to local regulation. To increase visibility, use the lights and devices provided with your machine. For some equipment, install extra flashing warning lights.

Keep safety items in good condition. Replace missing or damaged items. An implement safety lighting kit is available from your John Deere dealer.

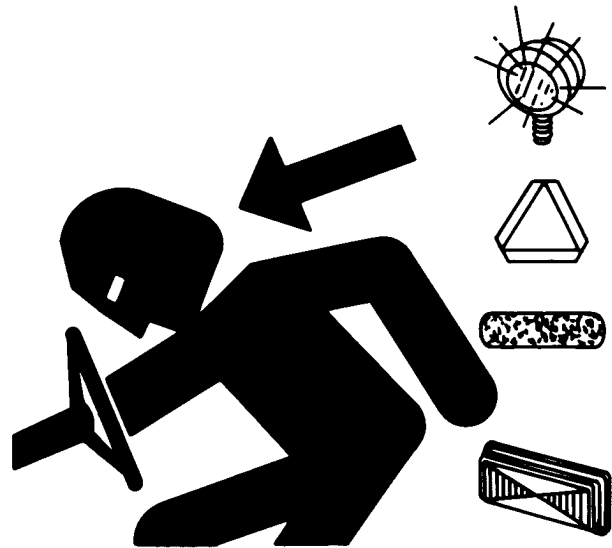

DX,FLASH -19-15MAR93

TS951 -UN-12APR90



USE A SAFETY CHAIN

A safety chain will help control drawn equipment should it accidentally separate from the drawbar.

Using the appropriate adapter parts, attach the chain to the tractor drawbar support or other specified anchor location. Provide only enough slack in the chain to permit turning.

See your John Deere dealer for a chain with a strength rating equal to or greater than the gross weight of the towed machine. Do not use safety chain for towing.

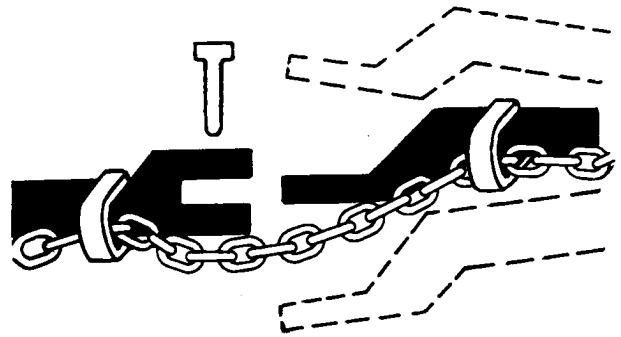

TS217 -UN-23AUG88

DX.CHAIN -19-03MAR93

PRACTICE SAFE MAINTENANCE

Understand service procedure before doing work. Keep area clean and dry.

Never lubricate, service, or adjust machine while it is moving. Keep hands, feet, and clothing from power-driven parts. Disengage all power and operate controls to relieve pressure. Lower equipment to the ground. Stop the engine. Remove the key. Allow machine to cool.

Securely support any machine elements that must be raised for service work.

Keep all parts in good condition and properly installed. Fix damage immediately. Replace worn or broken parts. Remove any buildup of grease, oil, or debris.

Disconnect battery ground cable (-) before making adjustments on electrical systems or welding on machine.



TS218 -UN-23AUG88

DX.SERV -19-03MAR93



REMOVE PAINT BEFORE WELDING OR HEATING

Avoid potentially toxic fumes and dust.

Hazardous fumes can be generated when paint is heated by welding, soldering, or using a torch.

Do all work outside or in a well ventilated area. Dispose of paint and solvent properly.

Remove paint before welding or heating:

- If you sand or grind paint, avoid breathing the dust. Wear an approved respirator.
- If you use solvent or paint stripper, remove stripper with soap and water before welding. Remove solvent or paint stripper containers and other flammable material from area. Allow fumes to disperse at least 15 minutes before welding or heating.



TS220 -UN-23AUG88

DX,PAINT -19-03MAR93

AVOID HEATING NEAR PRESSURIZED FLUID LINES

Flammable spray can be generated by heating near pressurized fluid lines, resulting in severe burns to yourself and bystanders. Do not heat by welding, soldering, or using a torch near pressurized fluid lines or other flammable materials. Pressurized lines can be accidentally cut when heat goes beyond the immediate flame area.



TS953 -UN-15MAY90

DX,TORCH -19-03MAR93



DISPOSE OF WASTE PROPERLY

Improperly disposing of waste can threaten the environment and ecology. Potentially harmful waste used with John Deere equipment include such items as oil, fuel, coolant, brake fluid, filters, and batteries.

Use leakproof containers when draining fluids. Do not use food or beverage containers that may mislead someone into drinking from them.

Do not pour waste onto the ground, down a drain, or into any water source.

Air conditioning refrigerants escaping into the air can damage the Earth's atmosphere. Government regulations may require a certified air conditioning service center to recover and recycle used air conditioning refrigerants.

Inquire on the proper way to recycle or dispose of waste from your local environmental or recycling center, or from your John Deere dealer.

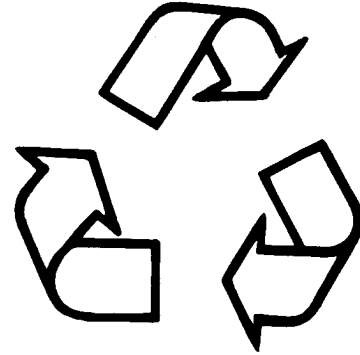

TS1133 -UN-26NOV90

DX,DRAIN -19-03MAR93



E38177 -UN-13OCT94



E38178 -UN-13OCT94



DANGER

TO AVOID PERSONAL INJURY:

1. Before hitching wagon to baler or working in or around ejector:
 - (a) Disengage tractor P.T.O.
 - (b) Wait until baler flywheel has stopped turning as it powers ejector.
 - (c) Raise side shields. Ensure lockout lever is in lockout position.
2. Never stand behind ejector while baler is operating.
3. Keep side screens lowered while operating.

E85514

-19-27OCT94 E38270

OME,42BE,SAF,B -19-26OCT94

Preparing the Bale Ejector

CHECKING AND ADJUSTING BALE EJECTOR BEFORE OPERATION

CAUTION: Never adjust the bale ejector with power engaged. Disengage PTO and shut off engine.

1. Lubricate according to Lubrication section.
2. Check for hydraulic oil leakage.

OME,42BE,GEN,A -19-26OCT94

BREAKING IN THE EJECTOR

Engage lockout (A). Run the ejector pump at slow idle speed. Gradually increase to full speed at the end of 30 minutes.

Disengage lockout (A). Hand trip ejector a minimum of five times each with distance dial set at two, four, and six. Run ejector pump at half throttle speed.

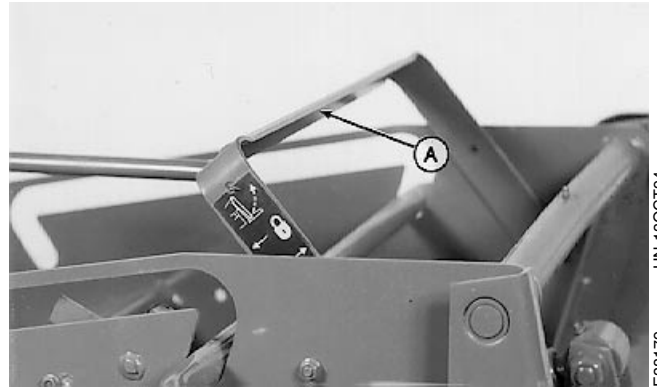

OME,42BE,GEN,B -19-26OCT94

E38179 -JUN-13OCT94

WAGON RECOMMENDATIONS

CAUTION: To prevent injury, always shut off tractor engine, disengage PTO, and engage lockout lever before hooking or unhooking wagon.

IMPORTANT: Do not overload the wagon. Bales falling off the wagon may strike the ejector and cause damage.

Wagon tongue must measure a minimum of 1397 mm (55 in.) (A) from the wagon bed to the hitch post.

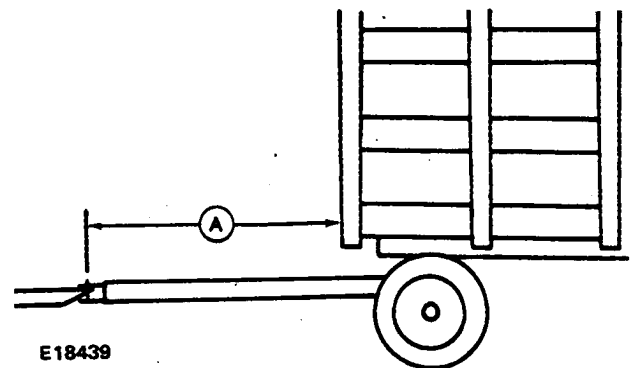

E18439

OME,42BE,GEN,C -19-26OCT94

E18439 -JUN-12SEP88

Preparing the Bale Ejector

If baler is equipped with optional automatic wagon hitch release (A), remove lockout pin (B) from transporting hole (C). Put lockout pin in storage hole (D).

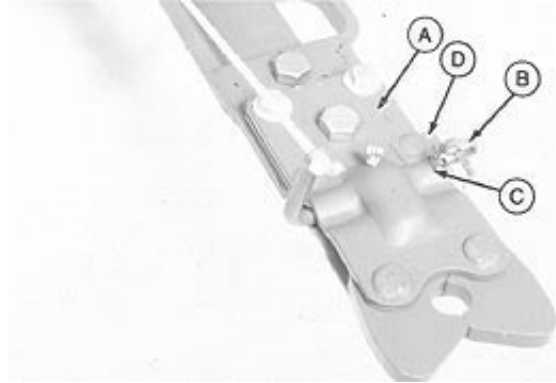

OME,42BE,GEN,D -19-26OCT94

E24529 -UN-22AUG89

Transporting

USE SAFETY CHAIN AND SAFETY LIGHTS

CAUTION: A safety chain will help control drawn equipment should it accidentally separate from the drawbar. Using the appropriate adapter parts, attach the chain to the tractor drawbar support or other specified anchor location. Provide only enough slack in the chain to permit turning. See your John Deere dealer for a chain with a strength rating equal to or greater than the gross weight of the towed machine. Do not use safety chain for towing.

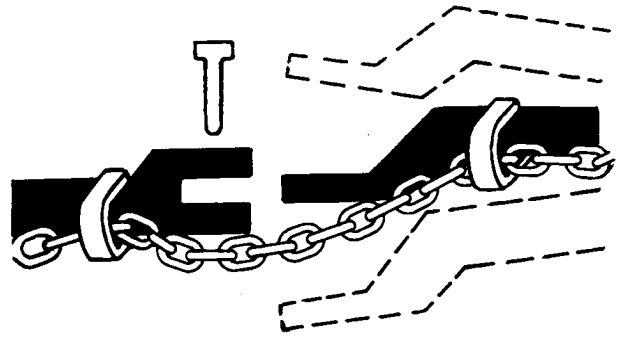

TS217 -UN-23AUG88

CAUTION: Slow moving tractors, self-propelled equipment and towed implements or attachments can create a hazard when driven on public roads. They are difficult to see, especially at night. Avoid personal injury or death resulting from collision with a vehicle.

Whenever driving on public roads, use flashing warning lights and turn signal according to local regulation. To increase visibility, use the lights and devices provided with your machine. For some equipment, install extra flashing warning lights.

Keep safety items in good condition. Replace missing or damaged items. An implement safety lighting kit is available from your John Deere dealer.

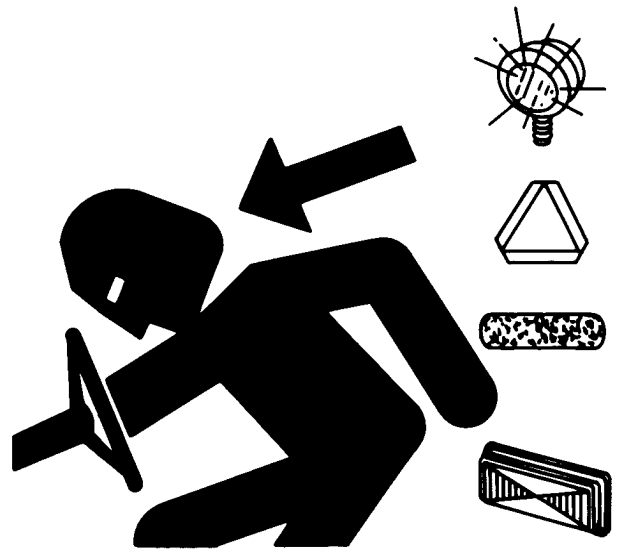

TS951 -UN-12APR90

OME,42BE,TRAN,A-19-26OCT94

TRANSPORTING WITH TRAILING WAGON

⚠ CAUTION: Before attaching safety chain, locking wagon hitch, servicing or adjusting any areas of the bale ejector, always:

- Disengage all power.
- Shut off engine.
- Wait until all moving parts have stopped.
- Move lockout lever to locked position.

1. Attach safety chain through loop (A). (See your wagon operator's manual for correctly attaching safety chain to wagon.)

2. If ejector is equipped with the optional wagon hitch release, remove lockout pin (B) from operating position. Put lockout pin in transporting position (C).

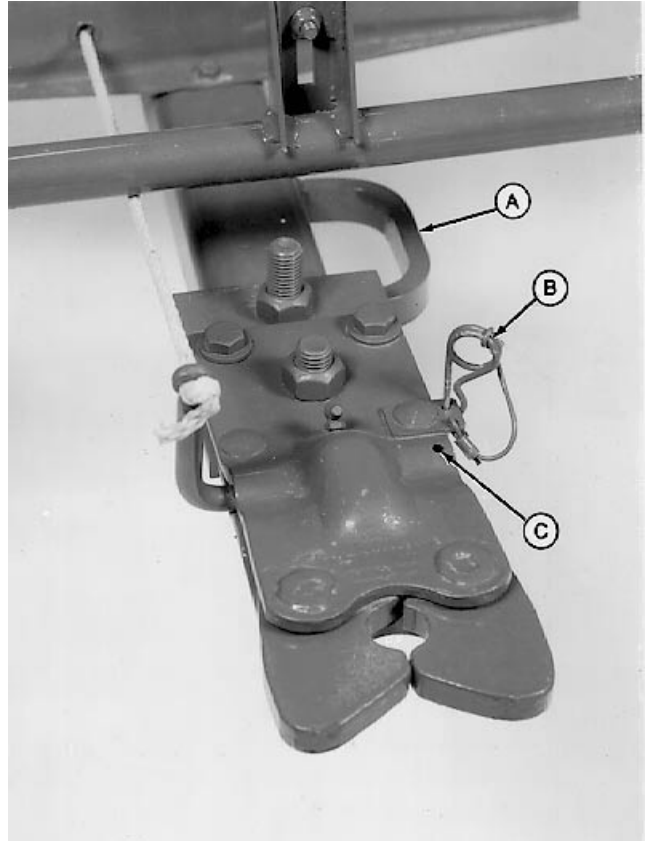

OME,42BE,TRAN,B-19-26OCT94

4. Lock wagon hitch in the right-hand position (A). This allows wagon to trail directly behind baler.

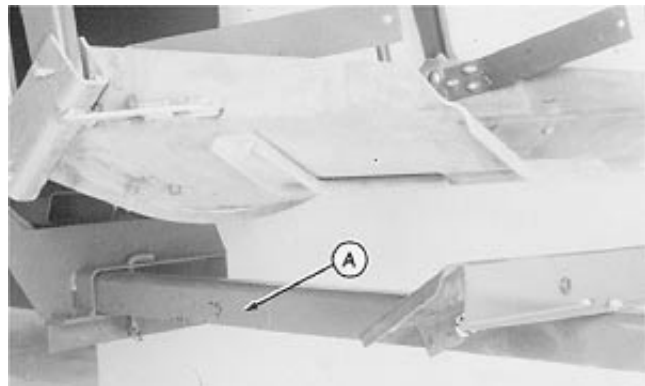

OME,42BE,TRAN,C-19-26OCT94

Operating the Bale Ejector

BALING WITH BALE EJECTOR

Variation in bale lengths and poor bale shapes may cause erratic operation of the ejector. If correct operating procedures are followed, the high capacity of the baler and ejector combination will be realized. (See STARTING AND OPERATING THE BALER in the Baler Operator's Manual.)

OME,42BE,OPER,A-19-26OCT94

EJECTING BALES

Ejecting bales onto the wagon depends upon location of wagon, angle of throwing pan, number of sharp corners, and contour of land.

Pivot ejector with a remote hydraulic cylinder or electric control to aim ejector more accurately on corners.

Turn distance dial to the lower numbers to keep bales from missing the wagon when turning corners.

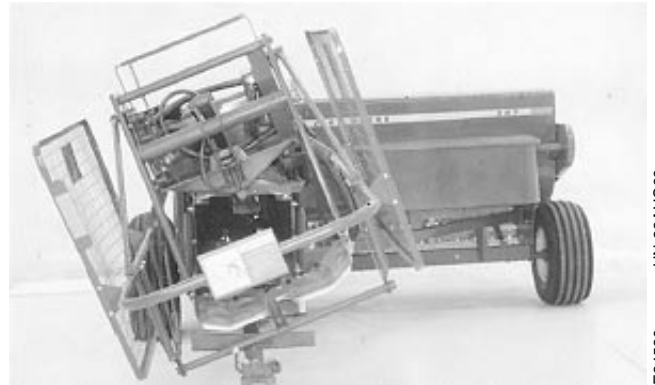

E24530 -UN-22AUG89

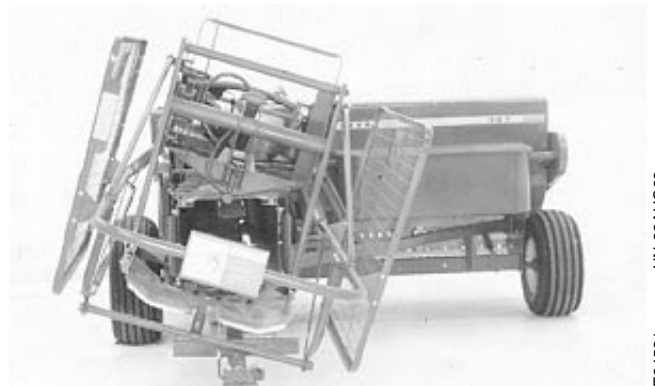

E24531 -UN-22AUG89

OME,42BE,OPER,B-19-26OCT94

BALE SIZE

The bale ejector will handle bales from 690 to 970 mm (27 to 38 in.) in length and up to 80 lb. (36 kg).

Bale density can be easily changed by regulating the tension adjusting screws, using the ratchet wrench furnished.

OME,42BE,OPER,C-19-26OCT94

USING ELECTRIC DISTANCE CONTROL

The distance dial (B) can be rotated to change the throwing distance.

- For a greater throwing distance, turn distance dial (B) to a higher number by pressing toggle switch (A) up.
- For a shorter throwing distance, turn distance dial (B) to a lower number by pressing toggle switch (A) down.
- Release toggle switch (A) when distance dial (B) reaches desired number.

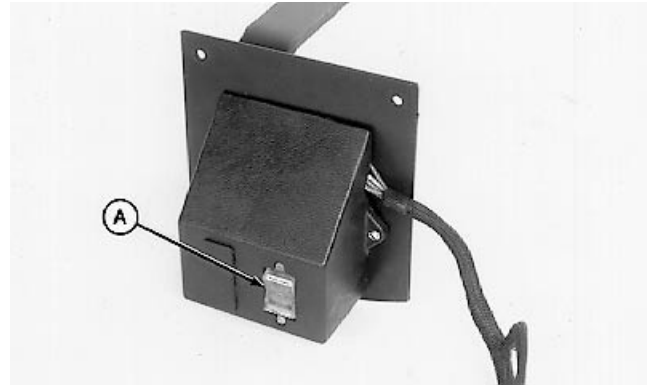

Toggle Switch



Distance Dial

OME,42BE,OPER,D-19-26OCT94

USING ELECTRIC HAND CONTROL (OPTIONAL)

The electric controls are located by the tractor seat. They can be located in a forward position (at end of tractor armrest), or in a rearward position (closer to the operator). (Refer to instructions in the Assembly section if necessary to change locations.)

IMPORTANT: Holding control lever after ejector has reached the maximum tilt will cause the circuit breaker to trip. If the circuit breaker trips, allow approximately 3 minutes for circuit breaker to reset.

- Move control lever right or left (A) to tilt ejector from side to side.
- Move control lever to front and rear (B) to decrease or increase the distance a bale is thrown.
- Release control lever when ejector has reached desired position.

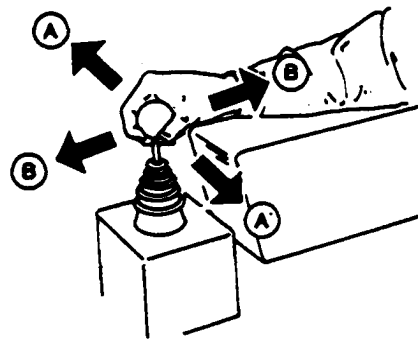

OME,42BE,OPER,E-19-26OCT94

OPERATING THE SIDE SCREENS

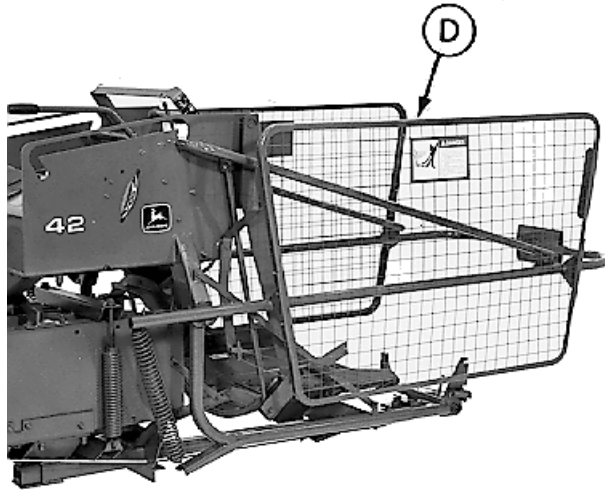

Operating Position

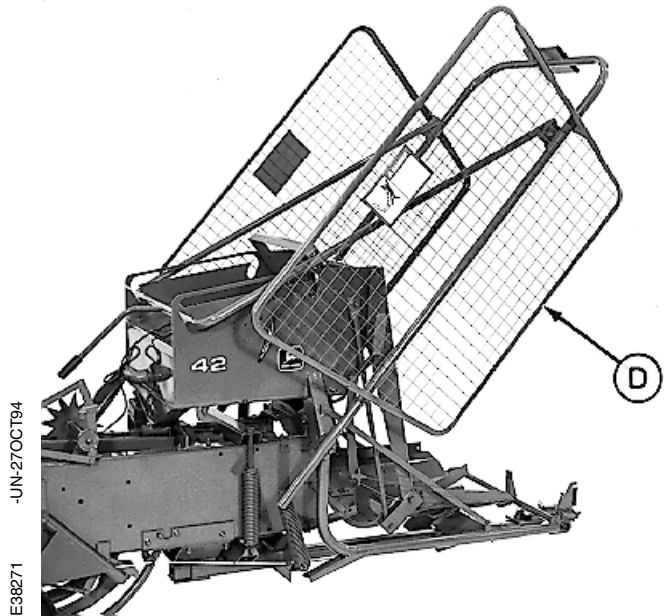

Servicing Position

CAUTION: To Prevent bodily injury, disengage PTO, stop tractor engine, and wait for all moving parts to stop before raising the side screens.

- Do not trip bale ejector with the side screens raised.
- Insure the lockout linkage is in working condition.

The side screens (D) provide protection from the throwing pan when the bale ejector is operational. The side screens can be raised to allow the servicing of the bale ejector, or access to the wagon hitch.

NOTE: Lockout lever (C) in lock out position prevents the trip lever from tripping the bale ejector.

1. To raise the side screens, for servicing the bale ejector, lift up and forward on handle (A). Handle will trip linkage (B), as it moves forward, causing the lock out lever (C) to move into lock out position.
2. To lower the screens, for operating or testing the bale ejector, lift up and rearward on handle.
3. Push the lock out lever rearward into operating position.

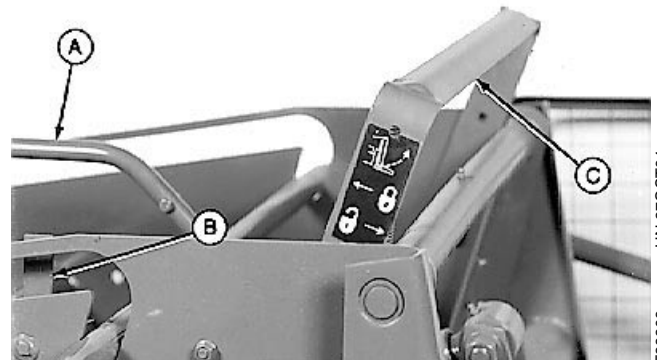

Lock Out Lever—Operating Position

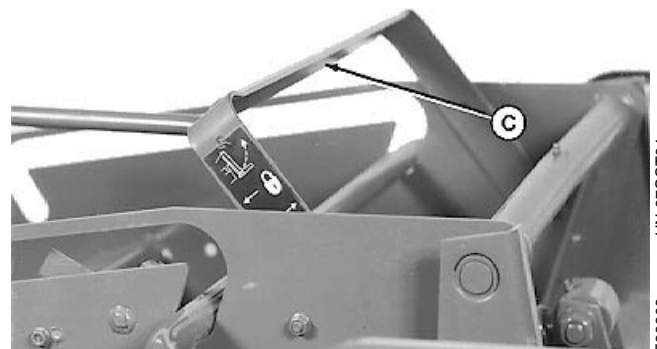

Lock Out Lever—Lock Out Position

A—Handle
B—linkage

C—Lever
D—Side Screens

OME,42BE,OPER,1-19-27OCT94

USING HAND-TRIP LEVER

⚠ CAUTION: To prevent bodily injury, never trip the bale ejector unless the side screens are lowered in the operating position.

With lock (A) in operating position, bale ejector works automatically or can be tripped by hand.

Operate manually by pushing on trip lever (B). Push lever rearward to trip ejector. Use this position to test the ejector.

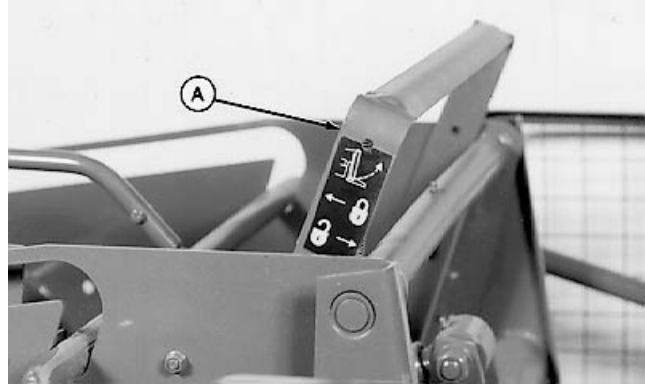

-JUN-13OCT94

E38183

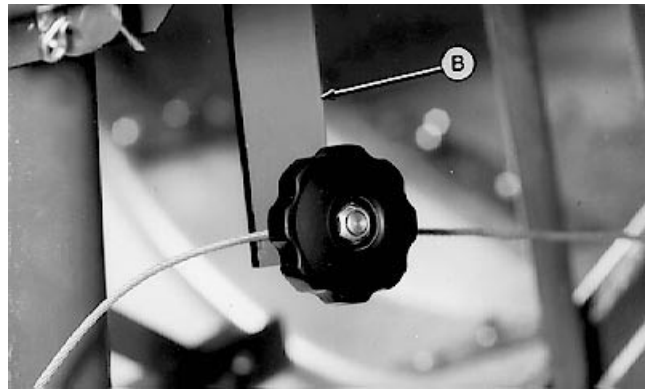

-JUN-13OCT94

E38184

OME,42BE,OPER,F-19-26OCT94

ADJUSTING BALE LENGTH TIMING

⚠ CAUTION: Before servicing or adjusting the machine:

1. Disengage all power.
2. Shut off tractor engine.
3. Wait until baler flywheel has stopped rotating.
4. Move lockout lever to locked position.

The ejector must trip when front end of bale is 102 mm (4 in.) (A) in front of the front edge of the throwing pan (B).

1. Adjust bale measuring arm to desired bale length between 686 and 965 mm (27 and 38 in.). (See ADJUSTING BALE LENGTH in this Operator's Manual.)

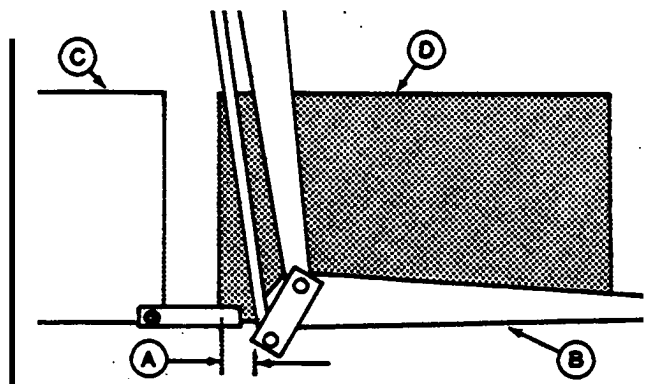

-JUN-05MAY89

E29278

- A—102 mm (4 in.)
- B—Throwing Pan
- C—Bale Case
- D—Bale of Hay

OME,42BE,OPER,G-19-26OCT94

Operating the Bale Ejector

2. Raise side screen (A).

3. Loosen knob and loosen trip cable (B). Tighten knob enough to prevent cable from falling out.

4. Move trip cable spring (C) to lower cap screw. Loosen set screws (D), and slide trip pedal support (E) to desired dimension. Tighten set screws.

5. If necessary, loosen flange nuts (F) and set height of trip pedal (G).

6. Adjust trip cable tension, (See ADJUSTING TRIP CABLE in this Operator's Manual).

- A—Side Screen
- B—Trip Cable
- C—Spring
- D—Set Screw
- E—Trip Pedal Support
- F—Flange Nut
- G—Trip Pedal

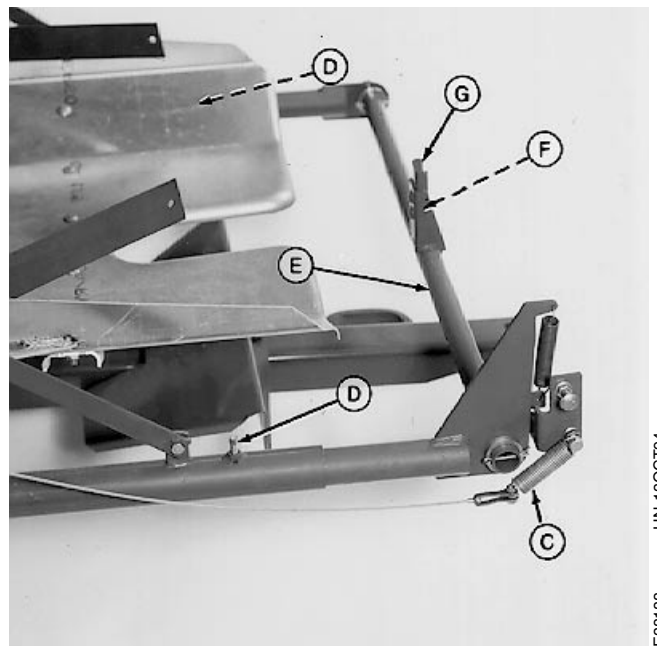
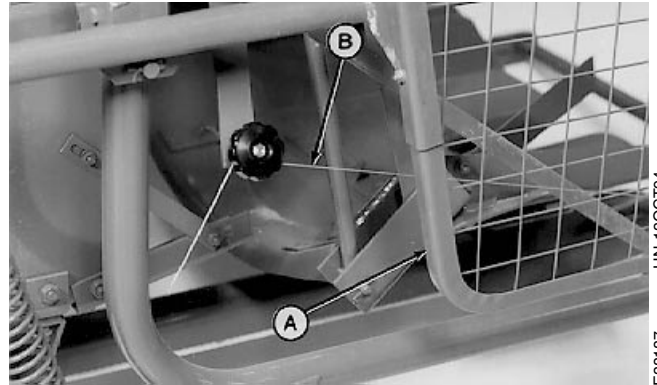

OME,42BE,OPER,H-19-26OCT94

7. Lower side screen (A).

8. Move lock (B) to operating position.

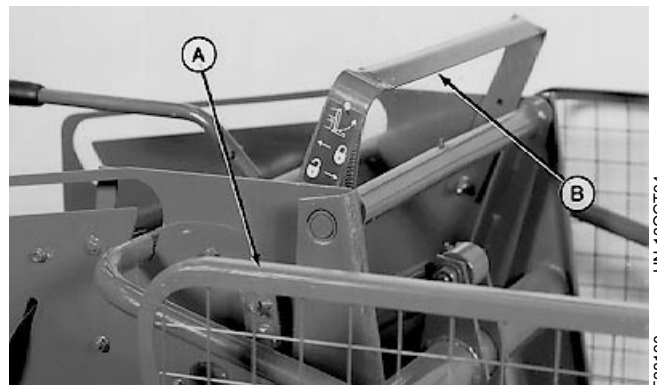

OME,42BE,OPER,O-19-26OCT94

THROWING-FRAME LATCH

If bales are not being ejected, the latch (D) may not be catching the throwing frame.

Check to see if throwing cylinder (A) is extended or there is a buildup of hay under the throwing pan (B). This can be seen from the operator's station on the tractor.

1. Stop tractor and put lever (C) in lockout position.
2. Remove bales that were not ejected.
3. Raise end of bale protruding from bale case so ejector pan can slide under bale and latch (D) throwing frame.
4. In this Operator's Manual see;

- ADJUSTING BALE CASE EXTENSIONS
- ADJUSTING BALE LENGTH TIMING
- ADJUSTING LATCH SPRINGS

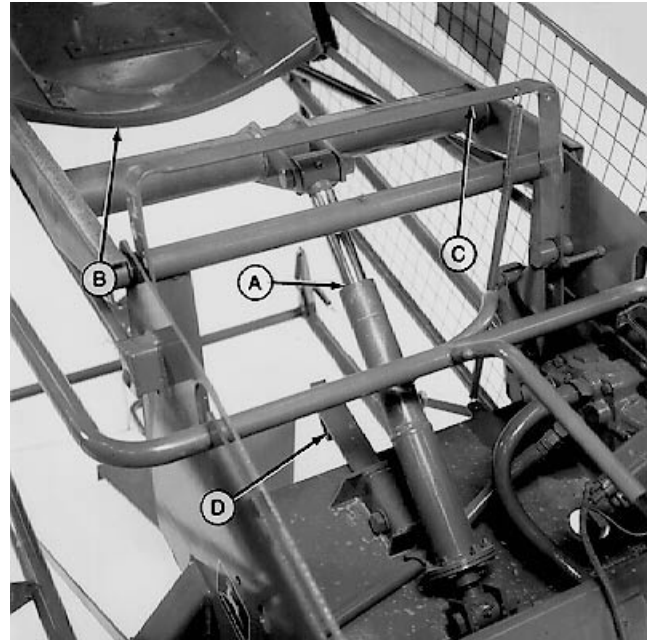

A—Throwing Cylinder
B—Throwing Pan
C—Lever
D—Latch

OME,42BE,OPER,I-19-26OCT94

ADJUSTING BALE WEIGHT

CAUTION: Before servicing or adjusting the machine:

1. Disengage all power.
2. Shut off tractor engine.
3. Wait until baler flywheel has stopped rotating.
4. Move lockout lever to locked position.

IMPORTANT: Bales too tight or too heavy cause excessive strain on the baler and ejector, contributing to undue breakage and wear of parts, and breakage of twine.

Loosen bale tension at the end of each days operation.

Bale weight is regulated by bale chamber tension. Adjust tension using upper (B) and lower bale case extensions and install side resistors (A).

Adjust upper and lower bale case extensions with adjuster (C), or optional hydraulic bale tensioner.

Bale weight is also affected by the size of windrows, moisture content and quality of hay. These factors may vary from hour to hour or windrow to windrow. Check bale weight regularly as this affects the throwing capabilities of the bale ejector.

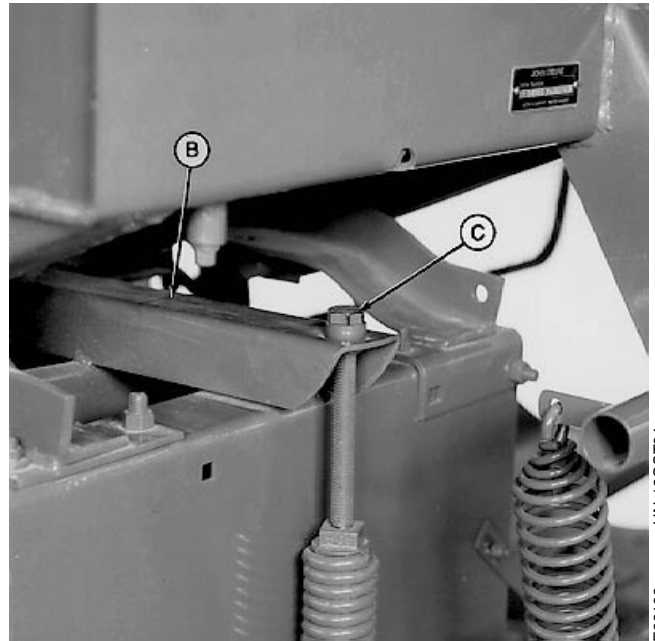
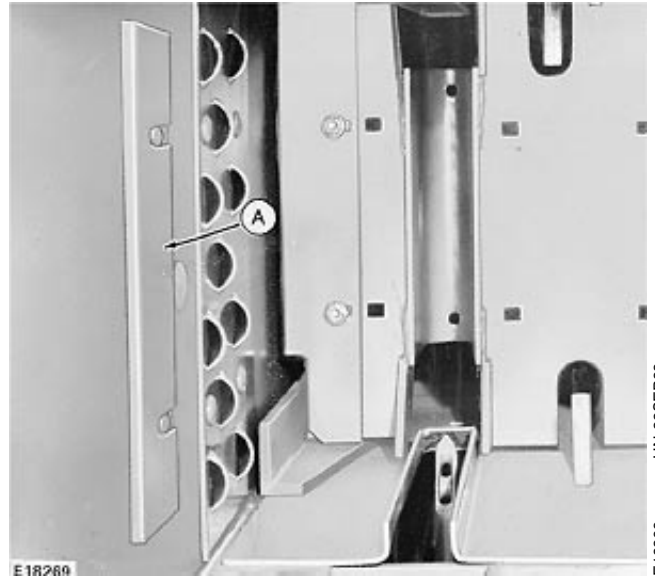

OME,42BE,OPER,J-19-26OCT94

ADJUSTING BALE LENGTH

Adjust bale measuring arm stop (A) on measuring wheel arm (B).

Raise stop (A) for bales up to a maximum of 965 mm (38 in.) long; lower the stop for bales as short as 690 mm (27 in.) long.

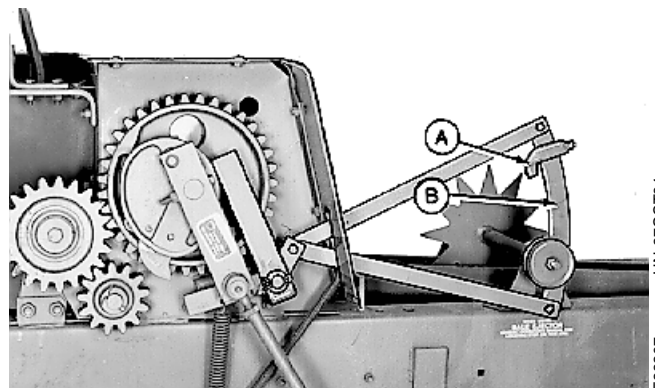

OME,42BE,OPER,K-19-26OCT94

USING OPTIONAL HYDRAULIC AIMING CONTROL

NOTE: Hydraulic cylinder must conform to ASAE-SAE standards.

A remote hydraulic cylinder can be used for side hill operation and when turning corners. Ejecting bales onto the wagon depends upon location of wagon, angle of throwing pan, number of sharp corners, and contour of land.

When turning corners, turn distance dial to the lower numbers to keep bales from missing the wagon.



E24545
-UN-22AUG89

OME,42BE,OPER,L-19-26OCT94

DROPPING BALES ON THE GROUND

NOTE: Do not attempt to automatically eject bales that have remained in the bale case while baler was not in use. Before starting to bale, put lock in lockout position and run out bales.

Put lock in lockout position (A) to drop bales on the ground.

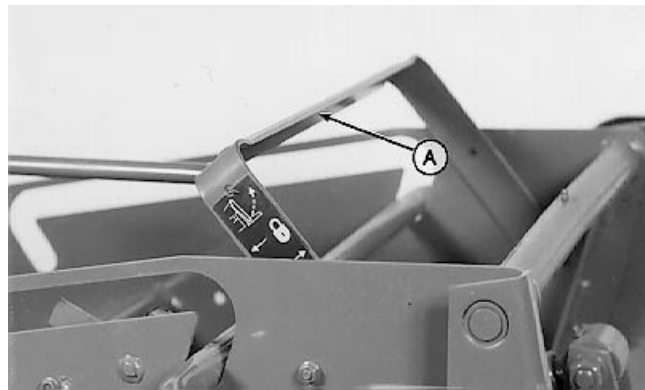

E38179
-JUN-13OCT94

OME,42BE,OPER,M-19-26OCT94

ADJUSTING BALE CASE EXTENSIONS

Bale case extensions provide clearance between bale and ejector pan. This clearance allows the pan to get under bale as the pan returns to home position.

NOTE: Adjust both extensions insuring they are positioned equally.

1. Loosen three nuts (A).
2. Adjust extension (B) to desired height. Tighten nuts (A).
3. If extensions are to high, preventing bales from tripping lever, loosen nuts (A) and lower extensions (B).

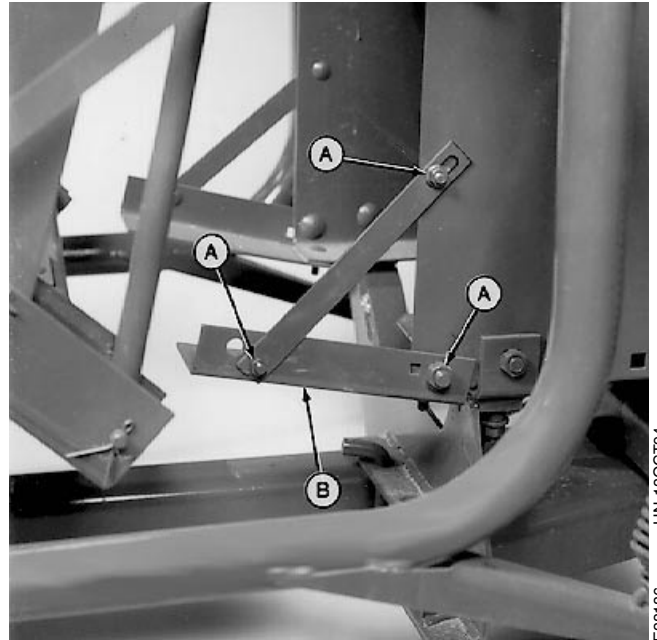

E38186
-UN-13OCT94

OME,42BE,OPER,N-19-26OCT94

Attachments

HYDRAULIC BALE AIMING CONTROL

The bale ejector pivots and throws bales up to 17° to side of bale case. This is helpful on hillsides and corners up to 90°. Ejector requires a remote hydraulic cylinder (A). (See Assembly section for installation.)

Additional hoses and supports may be required depending on model of baler. (See Assembly section.)

Refer to your tractor operator's manual for correct information regarding the hookup of the remote cylinder oil lines.

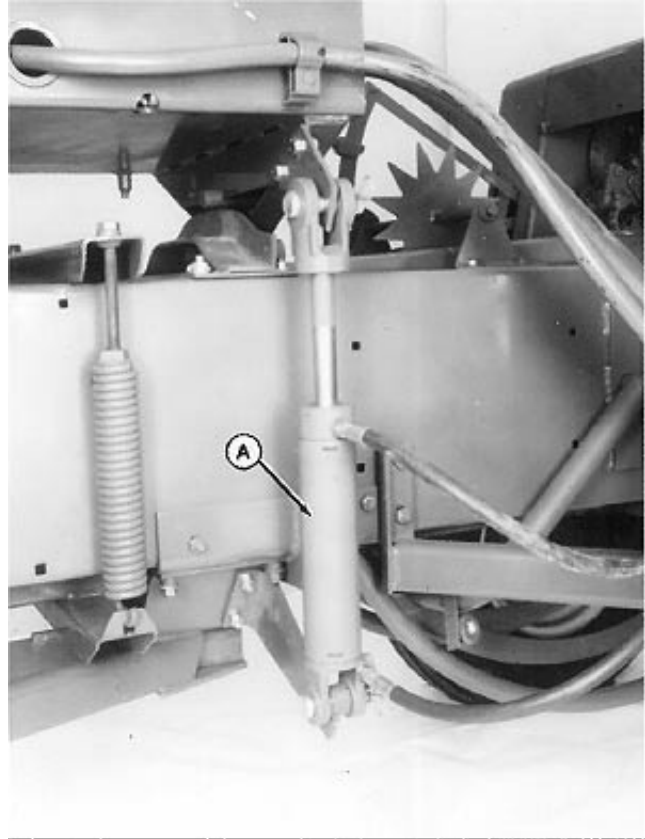

E38174
-UN-31MAY94

OME,42BE,ATT,A -19-26OCT94

ELECTRIC BALE THROWING DISTANCE AND TILT CONTROLS

The distance control (A) controls the distance a bale is thrown by operating a controller from tractor seat.

The tilt control (B) pivots the ejector and throws bales up to 17° to side of bale case. This is helpful on hillsides and corners up to 90°.

The electric controls are not recommended for the 24 and 224 Balers.

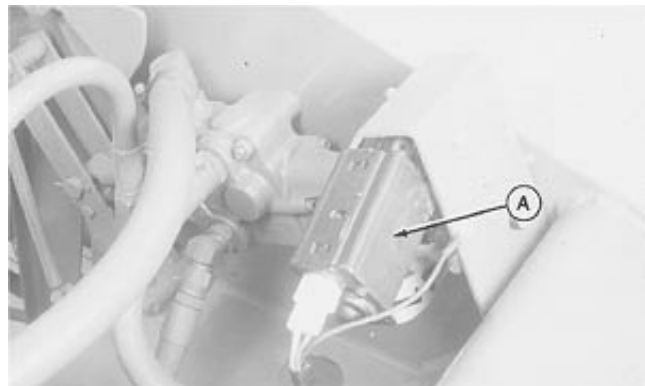

E24549
-UN-22AUG89

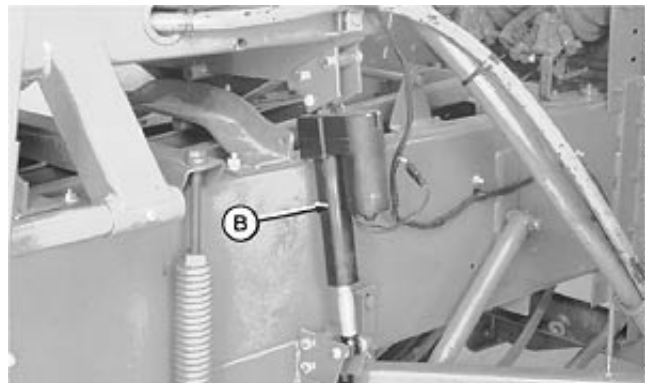

E24633
-UN-29AUG89

OME,42BE,ATT,B -19-26OCT94

WAGON HITCH RELEASE

The wagon hitch allows for releasing the wagon by pulling a rope from the tractor seat. The wagon hitch is not recommended for 24 and 224 Balers.

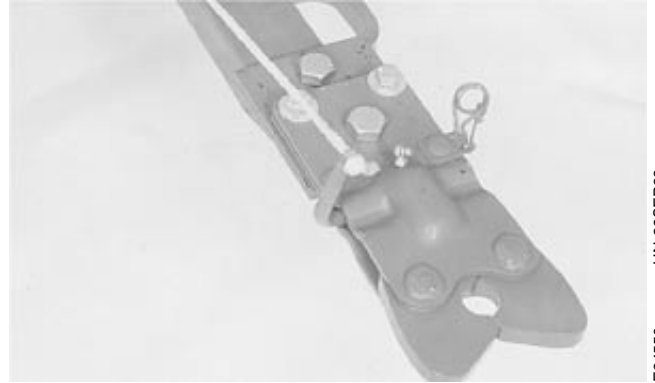

OME,42BE,ATT,C -19-26OCT94

E24550
-UN-22SEP88

HYDRAULIC CYLINDER KIT

The hose extensions (A) and couplers (B) extend the length of the hydraulic lines when 2840, 2940, 2950, or 3150 Tractors are used with the bale ejector.

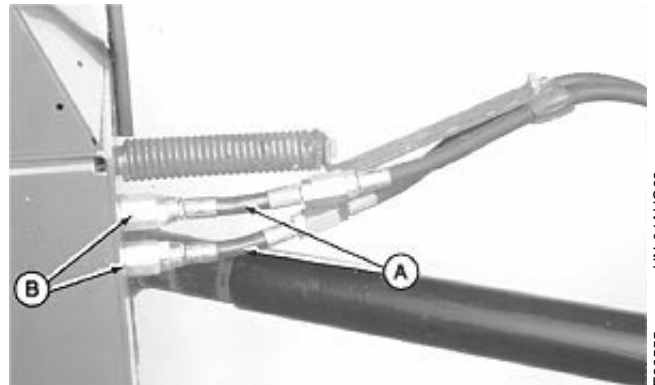

OME,42BE,ATT,D -19-26OCT94

E22555
-UN-04AUG89

Lubrication and Maintenance

PERFORM LUBRICATION AND MAINTENANCE

 **CAUTION:** Do not clean, lubricate, or adjust your machine while it is in motion.

1. Disengage all power.
2. Shut off tractor engine.
3. Wait until baler flywheel has stopped turning.
4. Put lockout lever in locked position.

IMPORTANT: The recommended intervals are based on normal conditions. Severe or unusual conditions may require shorter intervals.

Clean grease fittings before using grease gun. Replace any lost or broken fittings immediately. If a new fitting fails to take grease, remove and check for failure of adjoining parts.

Perform each lubrication and service illustrated in this section both at the beginning of the season, and at the end of the season.

OME,42BE,LUB,A -19-26OCT94

OBSERVE LUBRICATION SYMBOLS



Lubricate with John Deere EP Moly or an equivalent SAE multipurpose-type grease (unless otherwise specified) at hourly intervals indicated on the symbols.



Lubricate with SAE 30 or heavier oil at hourly intervals indicated on the symbols.



Brush periodically with John Deere EP Moly or an equivalent SAE multipurpose grease.

OME,42BE,LUB,B -19-26OCT94

GREASE

Use grease based on NLGI consistency numbers and the expected air temperature range during the service interval.

The following greases are preferred:

- John Deere HIGH TEMPERATURE EP GREASE
- John Deere MOLY HIGH TEMPERATURE EP GREASE
- John Deere GREASE-GARD™

Other greases may be used if they meet the following:

- NLGI Performance Classification GC-LB

Arctic greases (such as Military Specification MIL-G-10924F) may be used at temperatures below -30°C (-22°F).

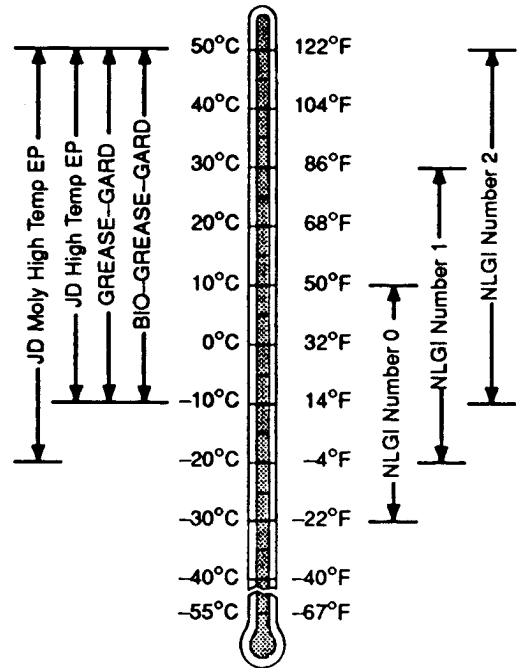

DX,GREA1

-19-17OCT94

TS1417
-UN-31 JAN94

HYDROSTATIC DRIVE OIL

Use oil viscosity based on the expected air temperature range during the period between oil changes.

The following oils are preferred:

- John Deere HY-GARD®
- John Deere Low Viscosity HY-GARD®

The following oil is also recommended:

- John Deere BIO-HY-GARD™¹

Other oils may be used if they meet one of the following:

- John Deere Standard JDM J20C
- John Deere Standard JDM J20D

Arctic oils (such as Military Specification MIL-L-46167B) may be used at temperatures below -30°C (-22°F).

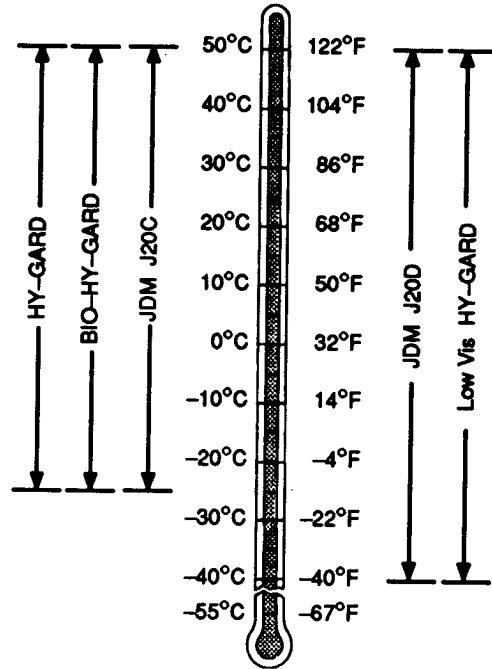

¹BIO-HY-GARD meets or exceeds the minimum biodegradability of 80% within 21 days according to CEC-L-33-T-82 test method. BIO-HY-GARD should not be mixed with mineral oils because this reduces the biodegradability and makes proper oil recycling impossible.

DX,HYOIL -19-01FEB94

TS1614 -UN-31JAN94

LUBRICANT STORAGE

Your equipment can operate at top efficiency only if clean lubricants are used.

Use clean containers to handle all lubricants.

Whenever possible, store lubricants and containers in an area protected from dust, moisture, and other contamination. Store containers on their side to avoid water and dirt accumulation.

DX,LUBST -19-01FEB94

ALTERNATIVE AND SYNTHETIC LUBRICANTS

Conditions in certain geographical areas may require lubricant recommendations different from those printed in this manual. Some John Deere lubricants may not be available in your location. Consult your John Deere dealer to obtain information and recommendations.

Synthetic lubricants may be used if they meet the performance requirements listed in this manual.

DX,ALTER -19-01FEB94

EVERY 10 HOURS

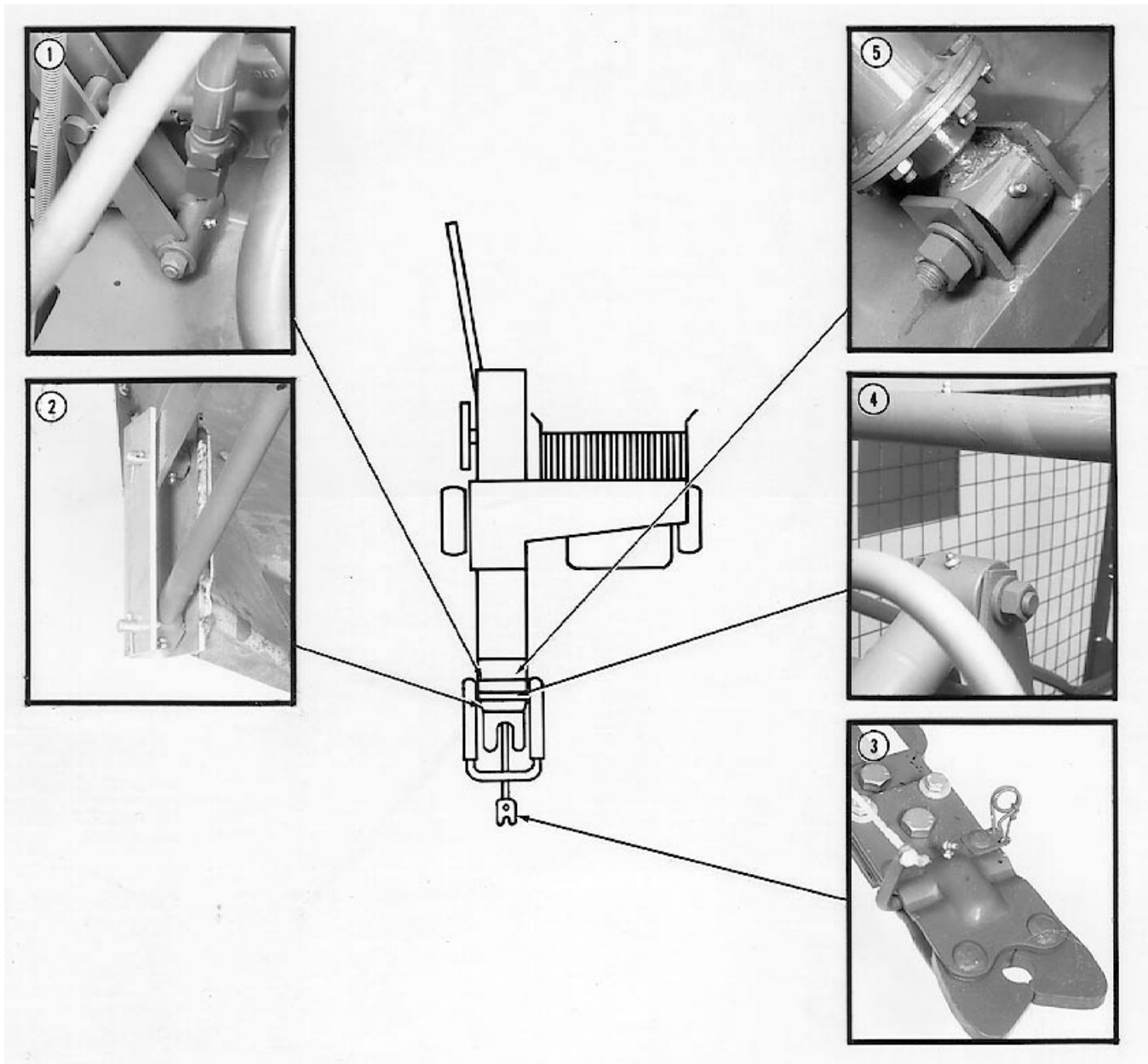

1—Pivot Shaft
2—Throwing Arms (Both Sides)

3—Automatic Wagon Hitch Disconnect (Optional)

4—Throwing Cylinder

5—Throwing Cylinder

E38195 -UN-13OCT94

OME,42BE,LUB,C -19-26OCT94

EVERY 10 HOURS

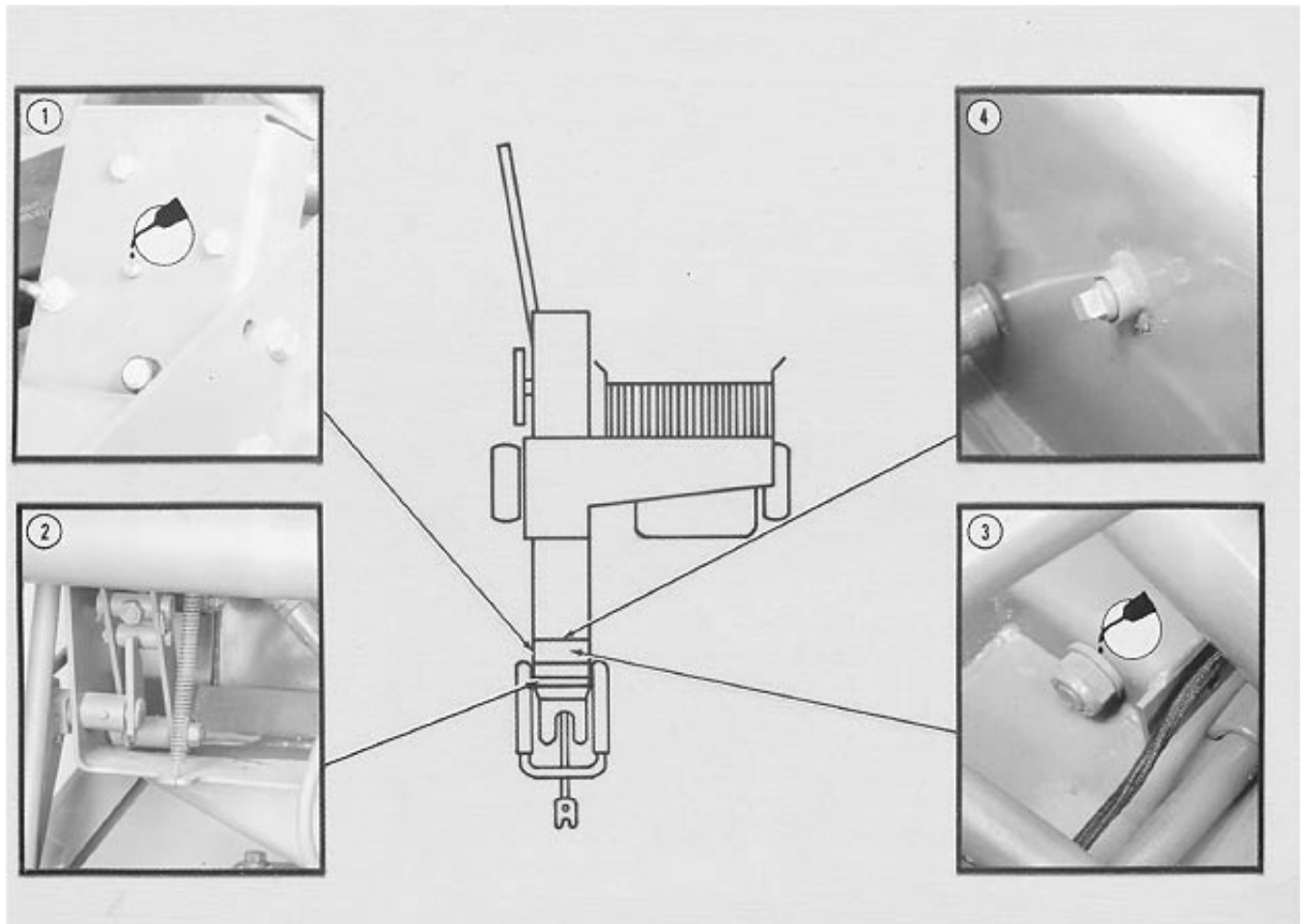

1—Electric Distance Control (Optional) (Oil Lightly)

2—Pivot Shaft

3—Cylinder Latch Mounting (Oil Lightly)

4—Reservoir (Fill to Check Plug Level with John Deere HY-GARD Transmission/Hydraulic Oil or equivalent hydrostatic fluid)

E24552 -UN-22AUG89

OME,42BE,LUB,D -19-26OCT94

EVERY 10 HOURS

Idler Pivot

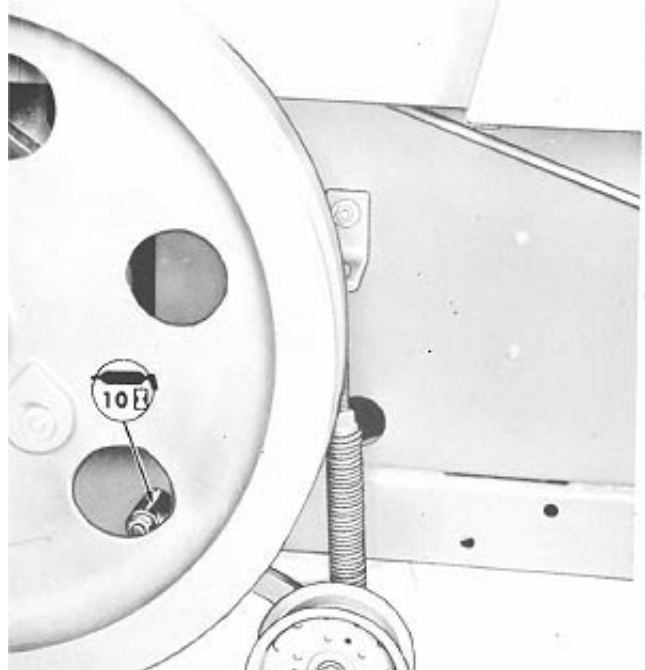

-JUN-15FEB93
E37069

OME,42BE,LUB,E -19-26OCT94

EACH SEASON

Relief Valve:

1. Mark spool cap (A) and valve body (B) for correct reassembly.
2. Remove two socket-head screws (C) and spool cap.
3. Coat end of spool (D) and detent springs inside cap (A) with John Deere Moly High Temperature EP grease or equivalent.
4. Install cap and tighten socket-head screws to 10 lb-ft (17 N·m).

- A—Spool Cap
- B—Valve Body
- C—Socket-Head Screw
- D—Spool

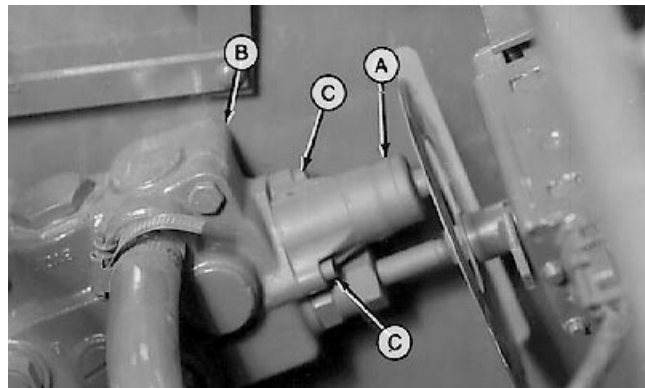

-JUN-13OCT94
E38234

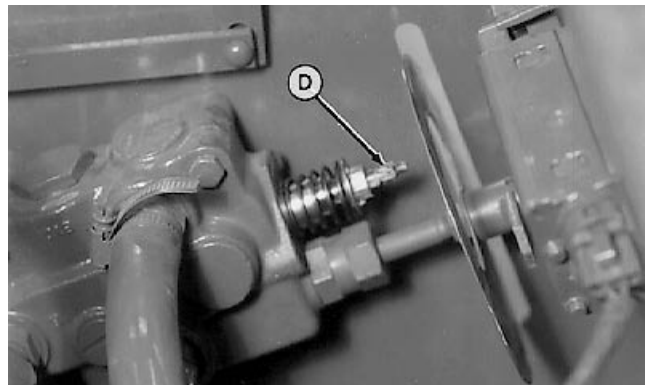

-JUN-13OCT94
E38235

OME,42BE,LUB,F -19-26OCT94

Troubleshooting

MISCELLANEOUS

Symptom	Problem	Solution
Bales thrown straight up, or roll end over end.	Ejector trips too soon before bale is out of bale case.	Check bale length timing. (See Adjusting Bale Length Timing in Operating the Bale Ejector section.)
	Broken bale spring on throwing pan.	Replace spring on throwing pan.
Throwing arms do not latch.	Ejector trips too late.	Check bale length timing. (See Adjusting Bale Length Timing in Operating the Bale Ejector section.)
	Pan hits oncoming bale in bale case.	Raise extension to top of slot. (See Adjusting Bale Case Extensions in Operating the Bale Ejector section.)
Ejector double trips.	Trip cable adjusted too short.	Adjust cable. (See Adjusting Trip Cable in the Service section.)
	Adjustment between control arm cam and trip bar roller incorrect.	Readjust. (See Adjusting Trip Cam in Service section.)
	Restriction in suction line.	Clean strainer. (See Changing Hydraulic Oil in Service section.) Repair restricted suction line.
	Not operating at proper PTO speed.	Refer to baler operator's manual.

OME,42BE,TRBL,A-19-26OCT94

HYDRAULIC PUMP

Symptom	Problem	Solution
Pump noise.	Air in oil.	Reservoir is low on oil. Add oil as necessary. (See Lubrication and Maintenance section.)
	Oil not of correct type.	Replace with correct oil. (See Lubrication and Maintenance section.)
	Parts in pump binding.	See your John Deere dealer.
	Reservoir strainer plugged.	Clean strainer. (See Changing Hydraulic Oil in Service section.)
	Low oil supply .	Fill reservoir to check plug level. (See Lubrication and Maintenance section.)
	Oil too heavy. Wrong type.	Change to John Deere HY-GARD Transmission/Hydraulic Oil or its equivalent. (See Lubrication and Maintenance section.)
	Air leak in inlet line.	Check for breaks or loose connections.
	Partly blocked inlet line.	Check for foreign object or clean system.
Foaming oil.	Water in the oil.	Check reservoir. Drain and refill. (See Changing Hydraulic Oil in Service section.)
	Low oil level.	Fill reservoir to check plug level.
	Air leaking into suction line.	Tighten fittings.
	Wrong type oil.	Change to John Deere HY-GARD Transmission/Hydraulic Oil or its equivalent. (See Lubrication and Maintenance section.)
Pump or oil overheating.	Oil supply low.	Fill to check plug level. (See Lubrication and Maintenance section.)
	Oil too thin in viscosity.	Change oil to John Deere HY-GARD Transmission/Hydraulic Oil or its equivalent. (See Lubrication and Maintenance section.)
	Oil supply contaminated.	Drain, clean strainer, and fill with John Deere HY-GARD Transmission/Hydraulic Oil or its equivalent. (See Changing Hydraulic Oil in Service section.)
	Oil going over relief with valve in neutral.	Adjust trip cam. (See Adjusting Trip Cam in Service section.)

Continued on next page

Troubleshooting

Symptom	Problem	Solution
Failure to build pressure.	Low oil supply.	Check and fill reservoir. (See Lubrication and Maintenance section.) Check for worn parts, replace if necessary.
	Valve leaks oil.	Hose fitting loose. Tighten hose fitting. Replace O-rings if necessary.
Throwing arms return home too fast.	Orifice broken between valve and hydraulic cylinder hose. Replace orifice.	
	Orifice installed backwards. Install with orifice slots toward outside of valve.	
Ejector does not trip.	Ejector locked out. Release lockout.	
	Bale does not contact trip pedal. Adjust trip pedal extension. Lower bale case extensions. (See Adjusting Bale Case Extensions in Operating the Bale Ejector section.)	
	Trip cable adjusted too long. Adjust cable (See Adjusting Trip Cable in the Service section.)	
	Binding in trip linkage. If more than 111 N (25 lbs) of pull is required to trip ejector, check trip linkage and valve for binding.	
	Hydraulic control valve inoperative. See your John Deere dealer.	
Oil leak around pump shaft.	Worn shaft seal. See your John Deere dealer.	
Oil leak around pump body.	Cap screws loose or not uniformly tight. Tighten all cap screws to recommended torque.	
	Damaged O-ring. See your John Deere dealer.	
Pump output low.	Drive belt loose. Tighten drive belt. (See Adjusting Pump Drive Belt in Service section.)	
	External leak in hydraulic system connections or cylinders. Tighten or replace.	
	Oil not of correct type. Replace oil with John Deere HY-GARD Transmission/Hydraulic Oil. (See Lubrication and Maintenance section.)	

Continued on next page

Troubleshooting

Symptom	Problem	Solution
	Dirt or sediment in pump.	Clean entire system of dirt. Clean strainer in reservoir. (See Changing Hydraulic Oil in Service section.)
	Excessive wear in pump.	See your John Deere dealer.
	Low oil supply.	Add oil to check plug level. (See Lubrication and Maintenance section.)

OME,42BE,TRBL,B-19-26OCT94

LATCH AND THROWING CYLINDER

Symptom	Problem	Solution
Cylinders will not operate or are slow to operate.	Low relief pressure.	See your John Deere dealer.
	Low oil level.	Add correct type oil. (See Lubrication and Maintenance section.)
	Pump worn or failed.	See your John Deere dealer.
	Sludge or dirt in system.	Drain system completely and clean. (See Changing Hydraulic Oil in Service section.)
	Leaking or restricted hydraulic lines.	Tighten fittings on all lines. Replace O-rings or leaking lines. Check all lines for restrictions or kinks.
Cylinder and throwing arms extended. Pump is running relief pressure.	Ejector tripped before starting baler.	Rotate lockout lever to reset valve. Return lockout lever to operating position; latch the throwing pan.
	Adjustment between control arm cam and trip bar roller incorrect.	Adjust. (See Adjusting Trip Cam in Service section.)
Cylinders leak oil.	Loose fitting hose.	Tighten hose fitting. Replace O-rings if necessary.
	Worn or damaged seals or gaskets.	See your John Deere dealer.
	Piston rod bent.	See your John Deere dealer.

OME,42BE,TRBL,C-19-26OCT94

CONTROL VALVE

Symptom	Problem	Solution
System sluggish. Does not respond or throw bales far enough.	Low system pressure.	Clean relief valve cartridge (relief valve staying open). (See your John Deere dealer.)
	Throwing cycle missed.	Valve spool sticking.
Ejector tripped, but bale is not thrown.	Drive belts slipping on pulleys.	Tighten idler tension spring. (See Adjusting Pump Drive Belt in Service section.)
	Obstruction in pan area.	Remove obstruction.
	Latch cylinder not operating.	See your John Deere dealer.
	Reservoir strainer clogged.	Clean strainer. (See Changing Hydraulic Oil in Service section.)
	Pressure line orifice installed backwards.	Check for correct installation. Install with orifice slot toward outside of valve
	Insufficient oil in reservoir.	Add oil to check plug level. (See Lubrication and Maintenance section.)
	Adjustable relief valve stop out of adjustment.	Readjust valve: 1. Loosen lock nut behind dial. 2. Rotate relief valve stem clockwise until it stops. 3. Rotate stop on stem until it touches frame on top. 4. Back off relief valve stem slightly (1—5 degrees). 5. Rotate dial to 8, do not rotate stem, tighten lock nut.
	Relief valve in control valve plugged.	See your John Deere dealer.
Valve spool sticking.	See your John Deere dealer.	

ELECTRICAL

Symptom	Problem	Solution
Neither control works. No power at tractor outlet socket.	Weak battery or poor ground.	Check battery and battery ground. Charge or replace.
	Circuit breaker in outlet circuit tripped.	Wait two minutes for breaker to reset.
	Loose connections.	Check and tighten connections. (See Wiring Diagram in Service section.)
Neither control works with power at tractor outlet socket.	Poor connections at switches.	Check and tighten switch connections.
	Switches failed.	Replace switches.
	Break in front wiring harness.	Repair or replace harness.
	Improperly installed or failed switch actuator springs. A "click" should be heard when control lever is moved in both directions.	Shorten or replace springs.
	Switch actuator spring loose in socket.	Shorten spring or replace.
Either control works in one direction only.	Switch not centered in neutral position.	Loosen mounting screws and position switch so actuator springs move switch same amount in both directions. (A "click" should be heard from switch in both directions.)
Distance control does not work.	Circuit breaker inside distance motor tripped.	Wait two minutes for breaker to reset.
	Poor connection at motor.	Check connections. (See Wiring Diagram in Service section.)
	Broken wire in circuit.	Check circuit. Repair or replace harness. (See Wiring Diagram in Service section.)
	Binding at distance control indicator, linkage, or stop.	Loosen attaching bolts. Reposition and tighten.
	Failed switch.	Replace switch.
Tilt motor does not work.	Circuit breaker inside tilt motor tripped.	Wait two minutes for breaker to reset.

Continued on next page

Troubleshooting

Symptom	Problem	Solution
	Clutch inside tilt motor slips ("rattle sound" can be heard).	Clean and grease ejector pivots. Loosen mounting brackets to eliminate binding. (See Lubrication and Maintenance section.)
Clutch inside tilt motor slips.	Rust in mounting bracket and pivots.	Clean and grease ejector pivots. Loosen mounting brackets to eliminate binding. (See Lubrication and Maintenance Department.)
	Misalignment of mounting brackets.	Clean and grease ejector pivots. Loosen mounting brackets to eliminate binding. (See Lubrication and Maintenance Department.)
Circuit breakers, inside either motor, trip too frequently .	Control lever held too long at end of cycle.	Release control lever at end of cycle. (See Using Electric Controls in Operating the Bale Ejector section.)
	Mounting bracket pivots binding.	Clean and grease pivots. (See Lubrication and Maintenance section.)
Control works backwards.	Wiring is reversed.	Rotate controller assembly 180 degrees, or switch wires at motor connections.
Tractor circuit breaker trips when baler harness is plugged into tractor connector on 12-volt positive ground system.	Wires reversed in connector.	Reverse wires in control harness connector. Allow tractor circuit breaker two minutes to reset. (See Wiring Diagram in Service section.)

OME,42BE,TRBL,E-19-26OCT94

Service

PRACTICE SAFETY

⚠ CAUTION: Before servicing or adjusting any areas of the bale ejector always:

1. Disengage all power.
2. Shut off engine.
3. Wait until all moving parts have stopped.
4. Move lockout lever (A) to locked position.

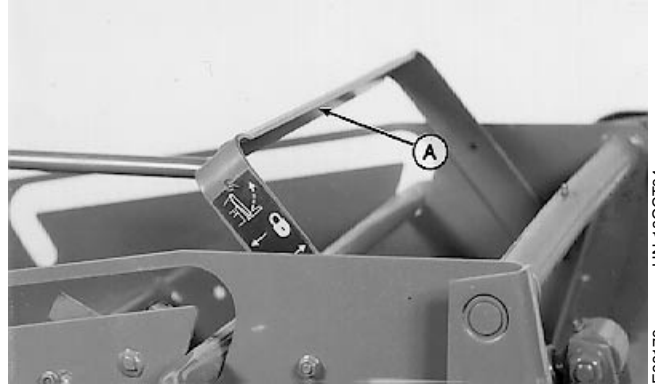

E38179 -UN-13OCT94

OME,42BE,SERV,A-19-26OCT94

ADJUSTING TRIP CAM

NOTE: Spring pin (G) in valve adapter (F) must be horizontal after adjustment or parts may bind.

1. Raise ejector side screens, engaging lockout (A).
2. Loosen trip cable.
3. Pull trip bar (B) out to extreme position. Clearance between the trip bar roller (C) and the radius in the end of the lockout (A) must be 7 to 8.3 mm (0.28 to 0.33 in.) (D).
4. To adjust, loosen lock nut (E) and turn valve adapter (F) until clearance is met. Tighten lock nut (E).
5. Adjust trip cable, (See ADJUSTING TRIP CABLE in this manual).
6. Lower ejector side screens.

- A—Lockout
- B—Trip Bar
- C—Trip Bar Roller
- D—7 to 8.3 mm (0.28 to 0.33-in.) Clearance
- E—Lock Nut
- F—Valve Adapter
- G—Spring Pin

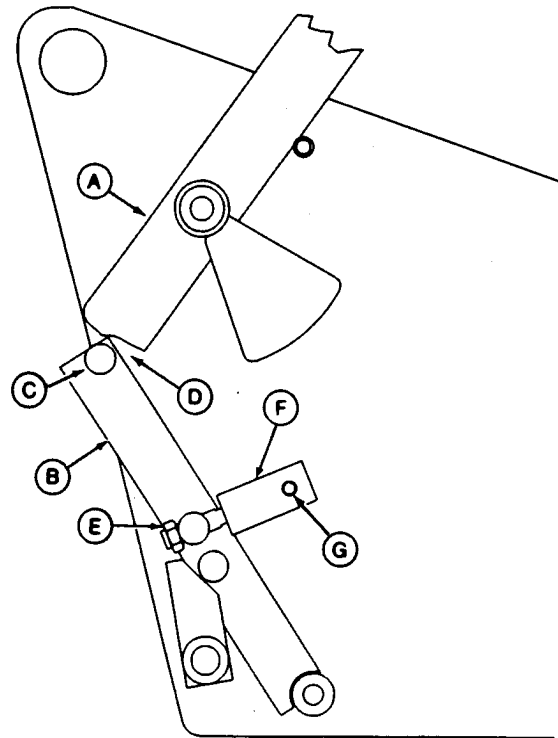

E37083 -UN-24FEB93

OME,42BE,SERV,B-19-26OCT94

ADJUSTING TRIP CABLE

NOTE: Before adjusting trip cable, check trip cam adjustment, (see ADJUSTING TRIP CAM in this manual)

1. Raise side screen (A). Lockout lever should be in lockout position.
2. Loosen knob (B) and cable (C).
3. Move spring (D) to bottom cap screw.

NOTE: Do not spread the spring (D) coils when adjusting the cable.

4. Ensure trip lever (E) is against trip bar roller (F). Remove slack from cable and tighten knob.

NOTE: When spring is in operating position, the cable will have some slack.

5. Move spring (D) to upper round head bolt (G).
6. Lower side screens and move lock lever to operating position.

A—Side Screen
 B—Knob
 C—Cable
 D—Spring
 E—Trip Lever
 F—Trip Bar Roller
 G—Round Head Bolt

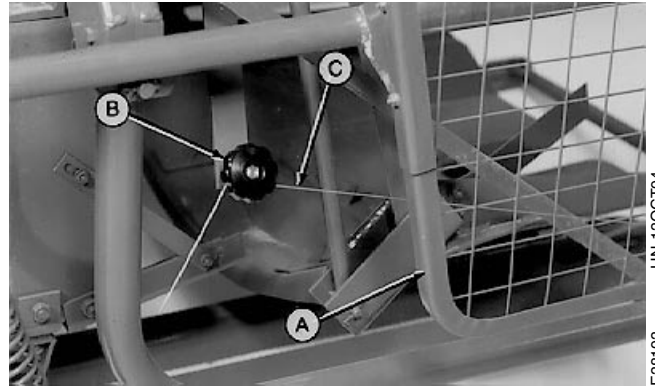

E38193 -UN-13OCT94

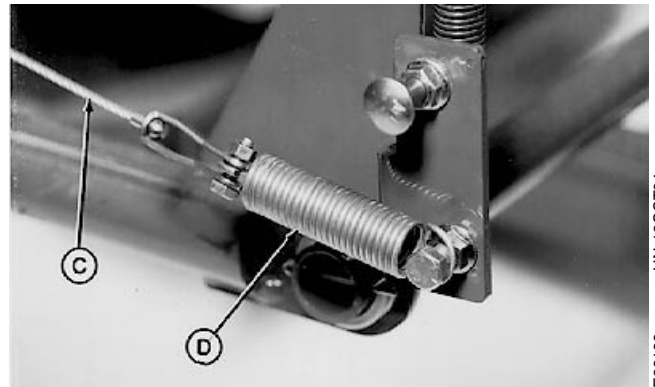

E38189 -UN-13OCT94

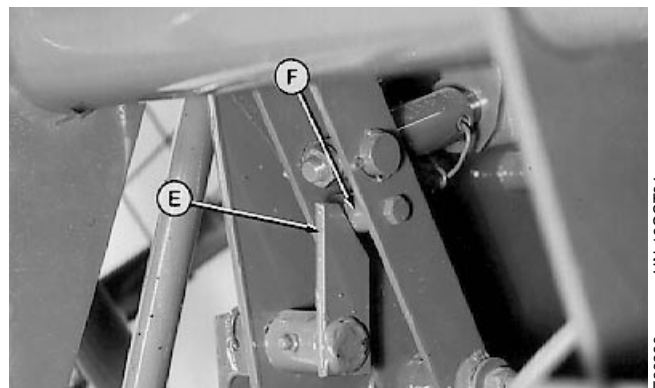

E38236 -UN-13OCT94

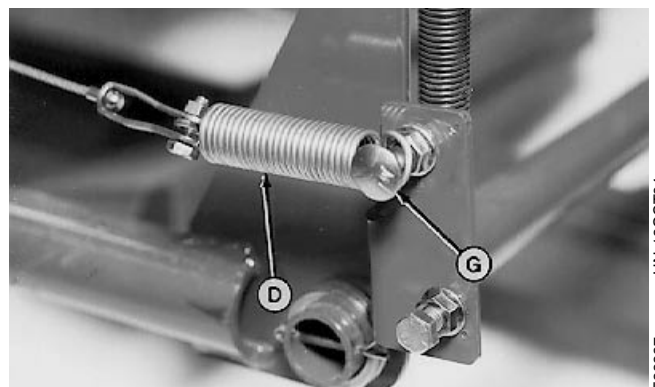

E38237 -UN-13OCT94

CHANGING HYDRAULIC OIL

CAUTION: Before removing drain plug, relieve pressure in reservoir by loosening cover bolts.

IMPORTANT: Keep oil clean; free of dust, water, and sealing compound.

1. Loosen bolts from cover (C). Do not remove cover at this time.
2. Remove drain plug (A).
3. Drain oil from reservoir (B).
4. Remove cover (C). Check cleanliness of strainer (D). (See Hydraulic System in Lubrication and Maintenance section.) Tighten finger-tight.
5. After completely drained, fill oil to check plug level with 32L (8.5 gal) John Deere HY-GARD Transmission/Hydraulic Oil or its equivalent.
6. Install cover and tighten cap screws.
7. Move lock lever to lockout position and run the ejector pump at slow idle speed, gradually increasing to full speed at the end of five minutes.
8. Move lock lever to operating position and manually trip ejector several times.
9. Visually check for leaks.

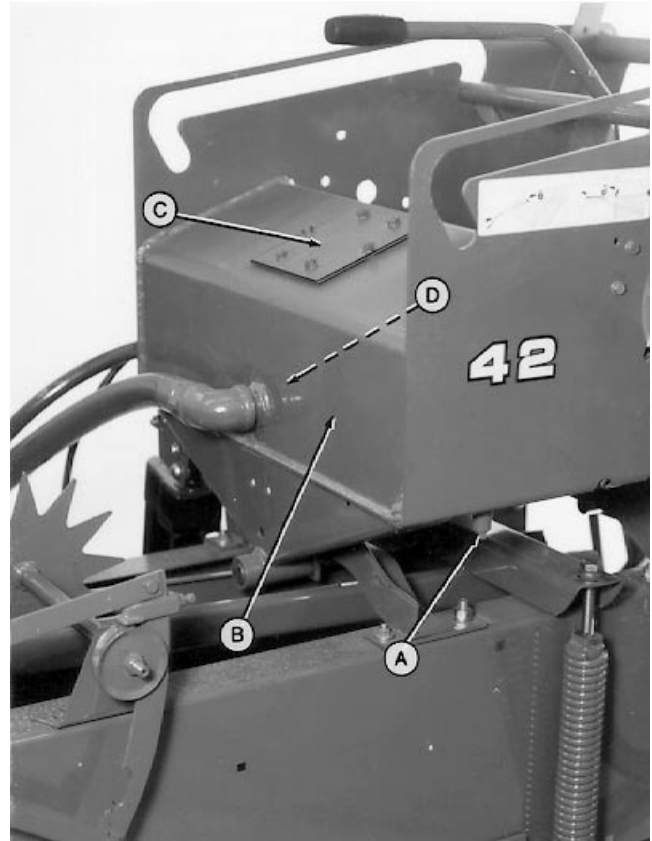

A—Drain Plug
B—Reservoir
C—Cover
D—Strainer

OME,42BE,SERV,D-19-26OCT94

E38194 -UN-13OCT94

ADJUSTING PUMP DRIVE BELTS

⚠ CAUTION: To prevent injury, do not check or adjust drive belts (A) while ejector is running. Never operate ejector with shield removed from drive belts.

1. Loosen locking nut (E).
2. Turn adjusting bolt (B) until tension spring (C) measures 226 to 232 mm (8-7/8 to 9-1/8 in.) (D) coil-to-coil.
3. Tighten locking nut.

A—Pump Drive Belts
 B—Adjusting Nut
 C—Tension Spring
 D—226 to 232 mm (8-7/8 to 9-1/8 in.)
 E—Locking Nut

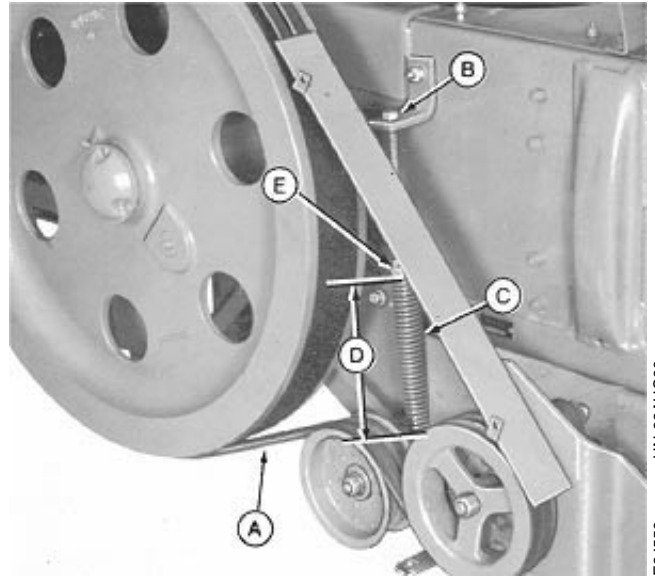

-UN-22AUG89
E24559

OME,42BE,SERV,E-19-26OCT94

ADJUSTING LATCH SPRINGS

Turn lock nuts (A) until springs are compressed to 89 mm (3-1/2 in.) (B).

A—Lock Nuts
 B—89 mm (3-1/2 in.)

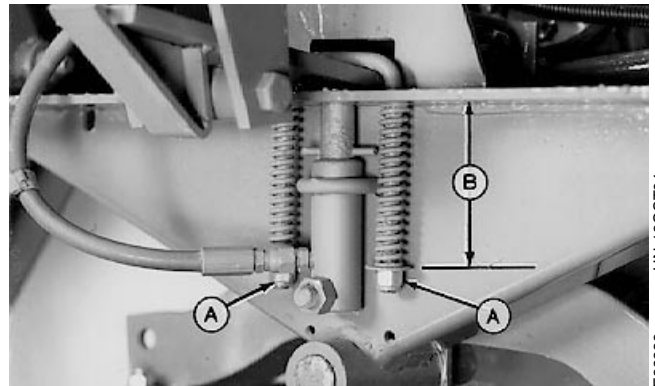

-UN-13OCT94
E38238

OME,42BE,SERV,G-19-26OCT94

WIRING DIAGRAM

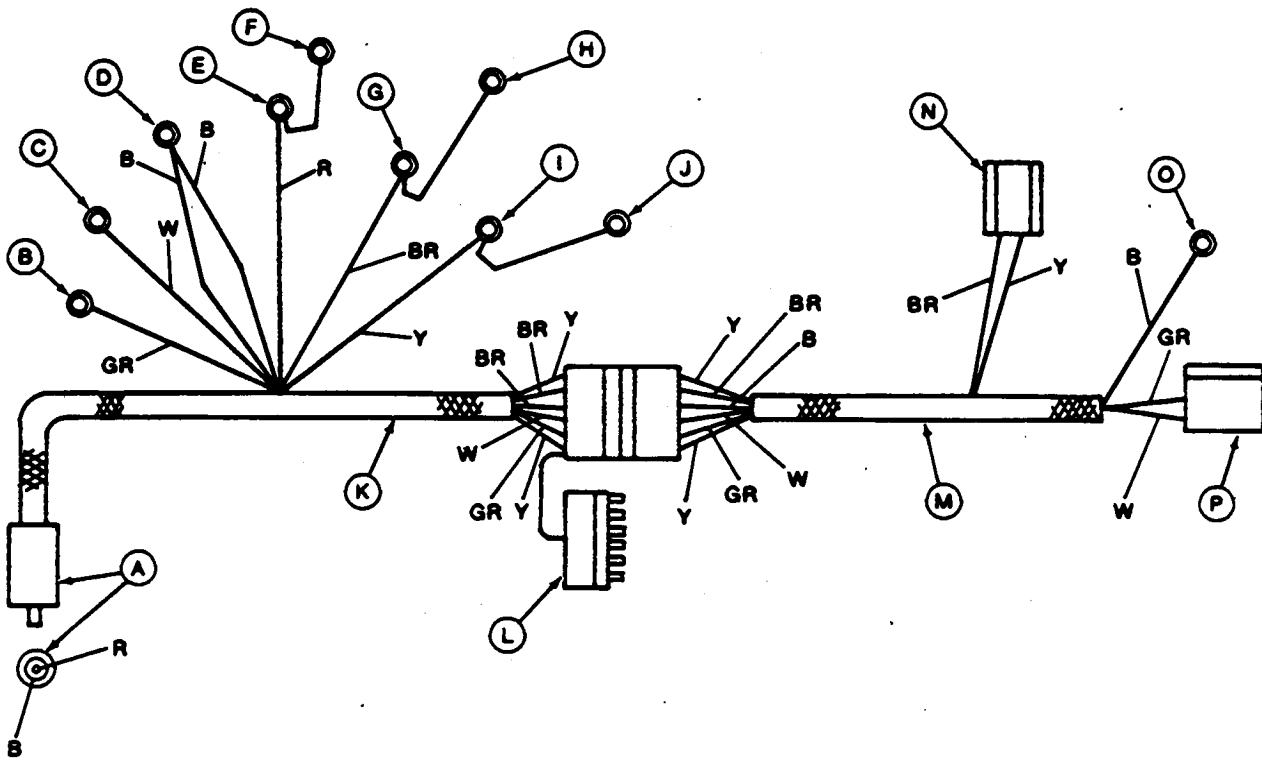

A—To Convenience Outlet
 B—Switch to Distance Motor
 C—Switch to Distance Motor
 D—To Ground
 E—To Power
 F—To Power

G—Switch to Tilt Motor
 H—To Tilt Motor Switch
 I—Switch to Tilt Motor
 J—To Tilt Motor Switch
 K—Front Harness
 L—Dust Cap

M—Rear Harness
 N—To Tilt Motor
 O—To Ground
 P—To Distance Motor
 B—Black

BR—Brown
 GR—Green
 R—Red
 W—White
 Y—Yellow

The electrical system consists of distance and control tilt motors actuated from the cab by a controller.

The color of each wire in the diagram above is abbreviated as follows:

The wiring diagram shows the color of each wire, the point to which it attaches and the routing of each wire in the harness.

B—Black
BR—Brown
GR—Green
W—White
R—Red
Y—Yellow

E24562 -UN-05MAY89

HYDRAULIC SYSTEM DIAGRAM

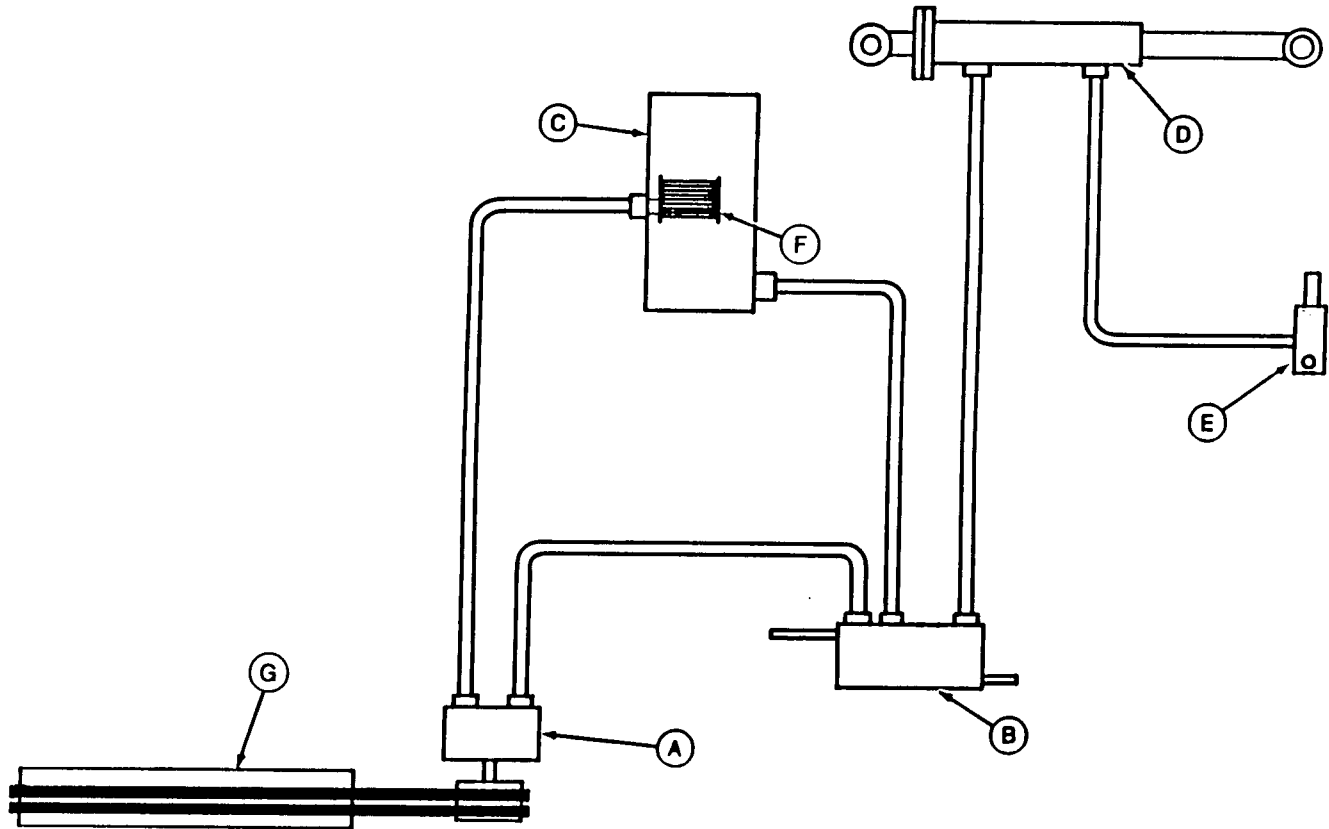

A—Hydraulic Pump
B—Control Valve

C—Reservoir
D—Throwing Arm Cylinder

E—Latch Cylinder
F—Strainer

G—Baler Flywheel

IMPORTANT: The hydraulic system is dependent on clean oil. (Refer to the Lubrication section for recommended intervals.)

The bale ejector uses an open-center hydraulic system. Hydraulic flow is from the hydraulic pump (A) through the control valve (B) and back to the reservoir (C).

When the bale contacts the trip pedal, a rod pushes the spring-loaded control valve out of spring-loaded detents. Oil is diverted to the throwing-arm cylinder (D) and latch cylinder (E), and the bale is thrown into the trailing wagon.

At a preset angle, the throwing arm is returned to the original position. When ejector is not throwing, oil is returned to the reservoir (C).

OME,42BE,SERV,I-19-26OCT94

E38173 -UN-31MAY94

Storage

END OF SEASON



E38239
-JUN-13OCT94

1. Put ejector in a dry place.
2. Clean ejector thoroughly, inside and out. Trash and dirt will draw moisture and cause rust.
3. Apply paint on parts from which the paint has been worn.
4. Thoroughly lubricate complete ejector according to the Lubrication and Maintenance section.
5. List replacement parts that will be needed and order them early.

OME,42BE,STOR,A-19-26OCT94

BEGINNING OF SEASON

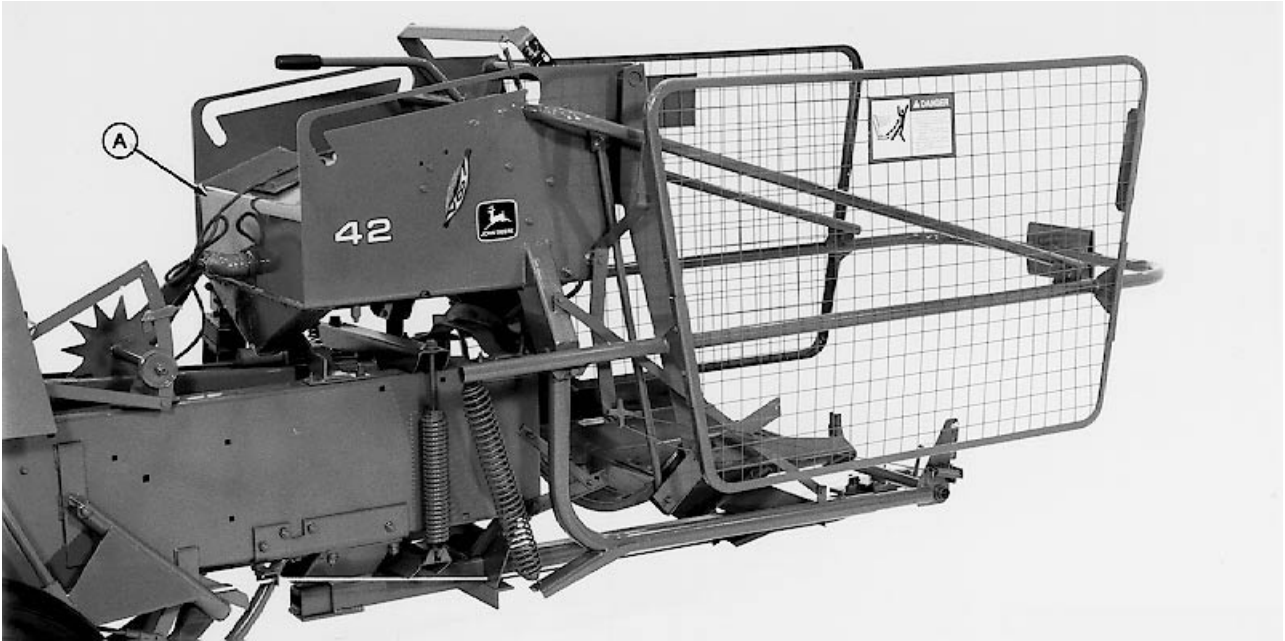

E38240
-JUN-13OCT94

1. Lubricate complete ejector according to the Lubrication and Maintenance section.
2. Tighten loose hardware.
3. Review operator's manual.
4. Make all necessary operating adjustments.
5. Check and fill reservoir (A).
6. Move lock lever to lockout position and run the ejector pump at slow idle speed, gradually increasing to full speed at the end of five minutes.
7. Move lock lever to operating position and manually trip ejector several times.
8. Visually check for leaks.

OME,42BE,STOR,B-19-26OCT94

Assembly

INSTALL WHEEL EXTENSIONS

For 336, 327, 337, 328, and 338 Balers:

Attach wheel extension with four 5/8 x 1-1/2-in. cap screws and nuts.

Remove wheel bearings and nut from original spindle and add to extension.

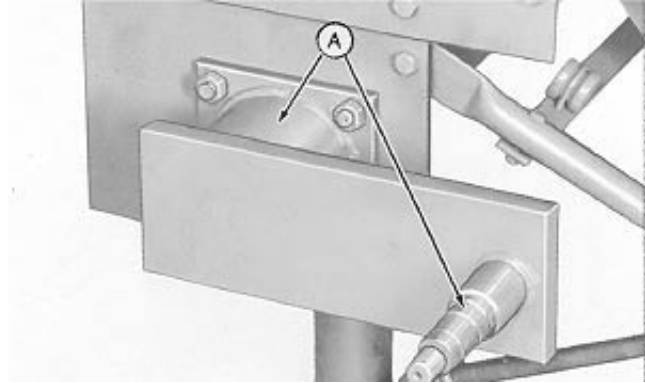

OME,42BE,ASY,A -19-26OCT94

E29127
-UN-07DEC89

For 346, 347, and 348 Balers:

Attach axle extension with four 5/8 x 4-1/2-in. cap screws (A) and four 5/8 x 2-1/2-in. cap screws (B) and nuts.

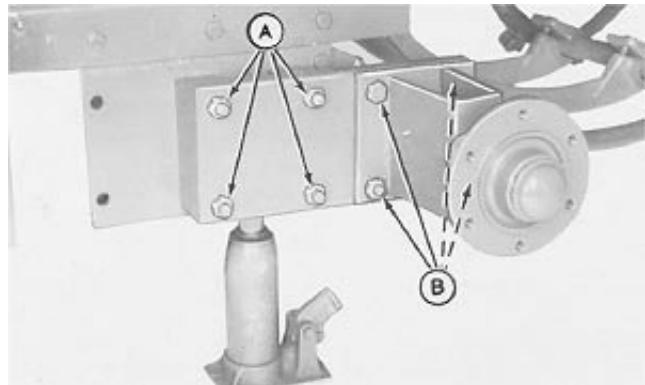

OME,42BE,ASY,B -19-26OCT94

E29126
-UN-07DEC89

Install axle extension with top of hub out as shown.

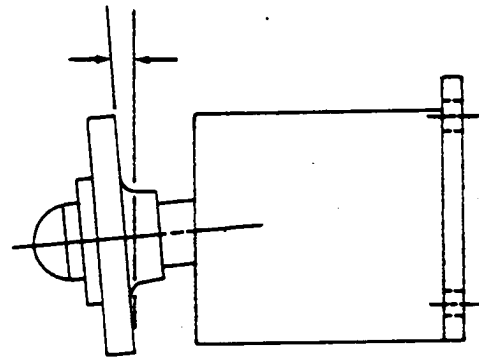

OME,42BE,ASY,C -19-26OCT94

E22545
-UN-20SEP88

INSTALL BALE EJECTOR ASSEMBLY (ALL BALERS)

1. Remove lower cross brace (A) and discard.
2. Remove both rear needle guard round-head bolts (B). Loosen front needle guard bolts.
3. Remove two round-head bolts (C), spacer(s), and nuts. Spacer(s) will not be reinstalled.

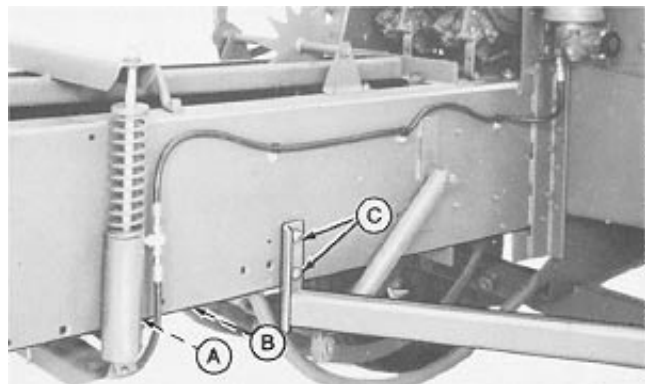

OME,42BE,ASY,E -19-26OCT94

E29281
-UN-07DEC89

Assembly

4. Slide hitch into place. Fasten with four 1/2 x 1-in. round-head bolts and nuts (A).

5. Repeat on opposite side using three 1/2 x 1-in. round-head bolts and nuts.

6. Install 7/16 x 1-1/4-in. round-head bolt and nut (B). Repeat on opposite side.

7. Install three 1/2 x 2-in. round-head bolts, 17/32 x 1-1/16 x 0.090-in. washers, and nuts (C). Repeat on opposite side.

8. Install 1/2 x 2-1/4-in. round-head bolt, 17/32 x 1-1/16 x 0.090-in. washer and nut (D). Repeat on opposite side.

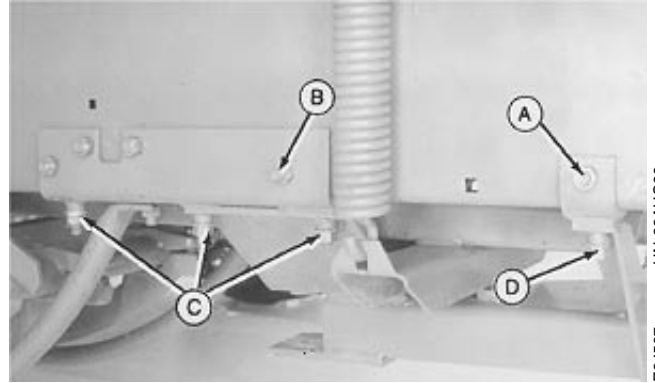

A—1/2 x 1-in. Round-Head Bolts and Nuts
B—7/16 x 1-1/4-in. Round-Head Bolt and Nut
C—Nuts
D—Nut

OME,42BE,ASY,F -19-26OCT94

-UN-22AUG89
E24567

NOTE: Heads of round-head bolts must be on inside of bale case.

9. Rectangular baler (-490000)

Attach bale case extension (A) with four 3/8 x 3/4-in. round-head bolts (B-C), two 13/32 x 1 x 0.060-in. washers on (C), and four nuts.

10. **Rectangular baler (490001-)** • Attach bale case extension (A) with 3/8 x 1-in. round-head bolt, and nut (B). Do not tighten at this time.

- Install 3/8 x 1-in. round-head bolt, 13/32 x 3/4 x 0.105-in. washer, extension, 13/32 x 3/4 x 0.105-in. washer, and lock nut (C).

- Attach strap using two 5/16 x 3/4-in. round-head bolts, 13/32 x 13/16 x 0.060 washers, and nuts (D).

11. Raise extension (A) to upper position and tighten. Repeat on opposite side.

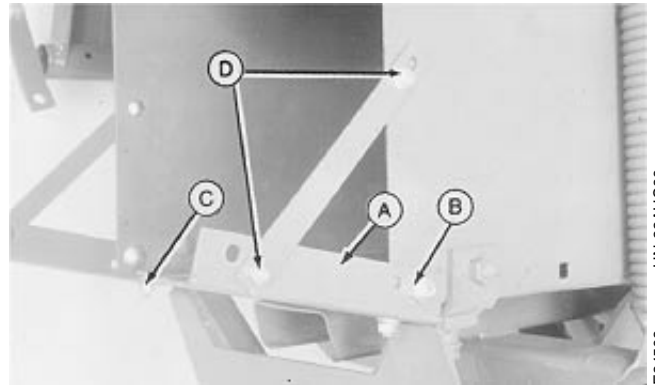

A—Bale Case Extension
B—Nut
C—Nut
D—Nut

OME,42BE,ASY,G -19-26OCT94

-UN-22AUG89
E24568

Assembly

12. Slide drawbar (A) into hitch. Fasten with 3/4 x 4-1/4-in. cap screw, spacer, and lock nut (B).

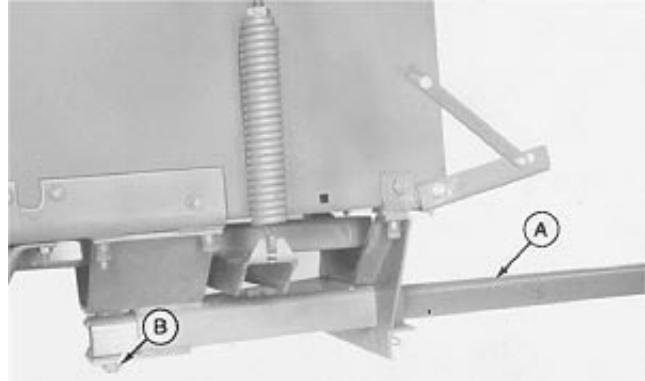

OME,42BE,ASY,H -19-26OCT94

E24569
-UN-22AUG89

13. Remove top brace (A).
14. Remove tension cranks (if installed) from springs (B) and install bolts provided.

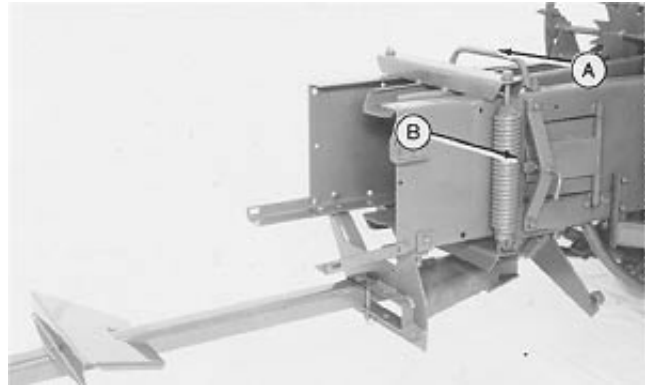

OME,42BE,ASY,D -19-26OCT94

E24565
-UN-22AUG89

15. Remove any paint or rust on pins of mounting brackets.
16. Coat pins with multipurpose grease or John Deere NEVER-SEEZ®.
17. Put three 13/32 x 1-3/4 x 0.060-in. washers on each mounting bracket.
18. Slide mounting bracket (B), with flat mounting pads, into ejector frame.
19. Slide mounting bracket (A), with angle mounting pads, into ejector frame.
- IMPORTANT: To prevent damage, do not attach hoist to throwing cylinder or any other location except frame of ejector.**
20. Attach hoist to ejector main frame and position on baler.

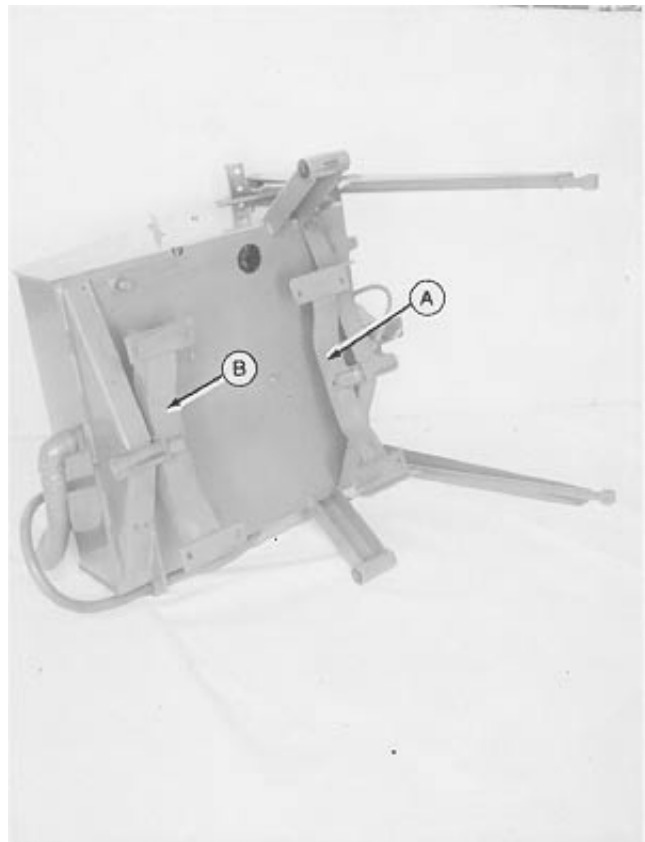

OME,42BE,ASY,I -19-26OCT94

E24571
-UN-22AUG89

NEVER-SEEZ is a trademark of Emhart Chemical Group.

Assembly

21. Install stationary link (A). Fasten with one 1/2 x 1-1/4-in. cap screw, and nut.

22. Align holes in ejector frame to bale case. Add or remove 1-3/32 x 1-3/4 x 0.060-in. washers (installed in step 17) until space between mounting bracket and ejector frame is removed.

23. **Rectangular baler (-490000)** Attach ejector to bale case using ten 3/8 x 1-in. round-head bolts, 13/32 x 1 x 0.134-in. washers, and nuts (C).

Rectangular baler (490001-) Attach ejector to bale case with four 1/2 x 1-1/4-in. round-head bolts, 13/32 x 1 x 0.134-in. washers, nuts (B), six 3/8 x 1-in. round-head bolts, 13/32 x 1 x 0.134-in. washers, and nuts (C).

24. Remove wire from latch cylinder hose.

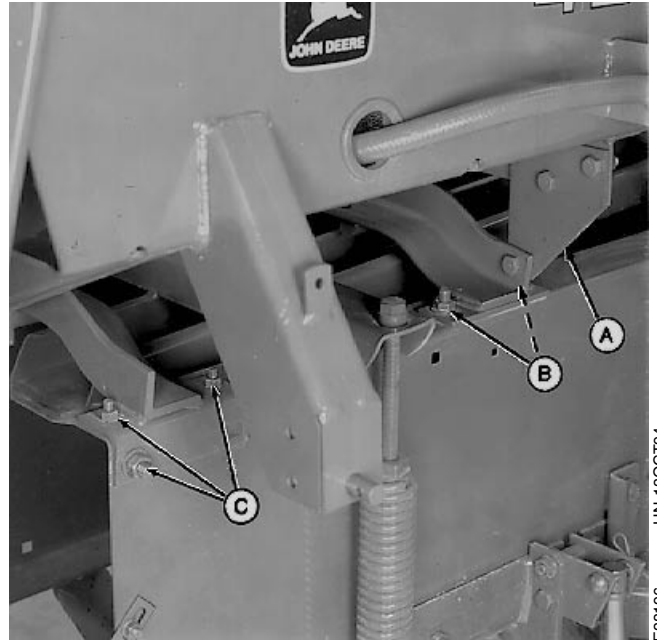

-UN-13OCT94
E38196

OME,42BE,ASY,J -19-26OCT94

25. Install throwing pan (A). Fasten with four drilled pins (B) and 5/32 x 1-in. cotter pins (C).

26. Attach bale springs (D) to throwing pan. Fasten with two 5/16 x 1-in. cap screws, four 5/16 x 3/4-in. cap screws, six 11/32 x 11/16 x 0.060-in. washers, and nuts.

- A—Throwing Pan
- B—Drilled Pins
- C—Cotter Pins
- D—Bale Springs

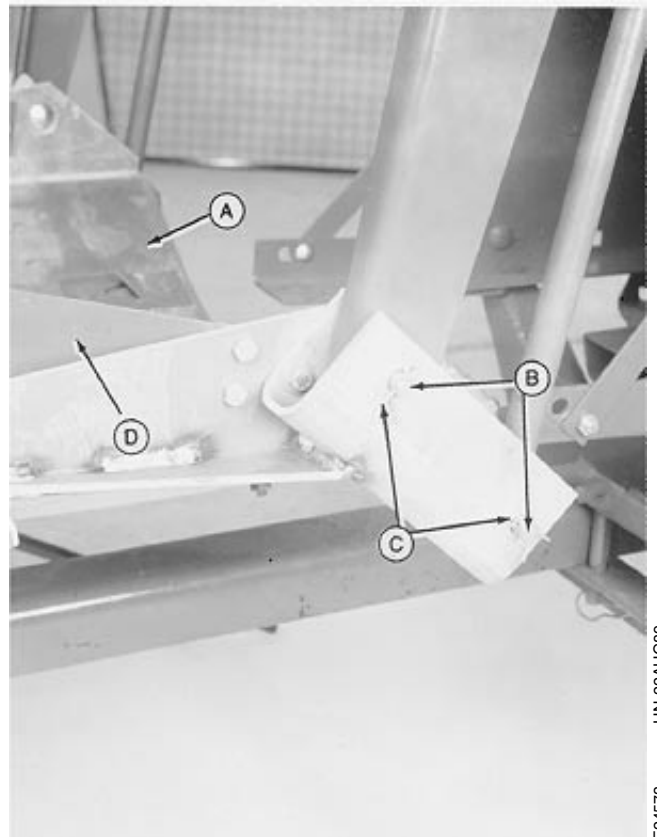

-UN-22AUG89
E24573

OME,42BE,ASY,K -19-26OCT94

Assembly

27. Attach ramp (A) to hitch. Fasten with 5/16 x 3/4-in. self-tapping screw, 5/16 x 3-1/2-in. cap screw, and nut.

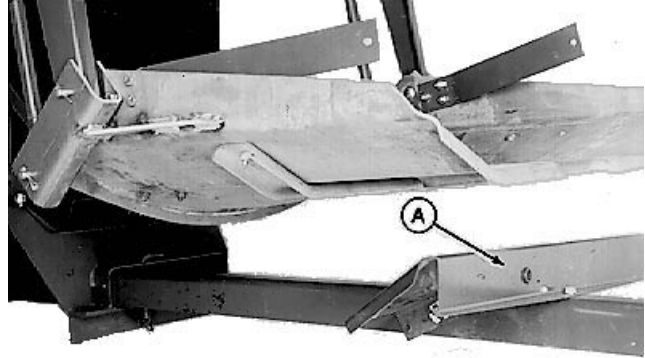

OME,42BE,ASY,L -19-26OCT94

E38266
-UN-21OCT94

28. Attach trip supports (A) to right and left side of ejector. Fasten with four 3/8 x 3-in. cap screws and lock nuts.

29. Attach brace (B) to right and left trip support members using four 5/16 x 3/4-in. cap screws and serrated flange nuts.

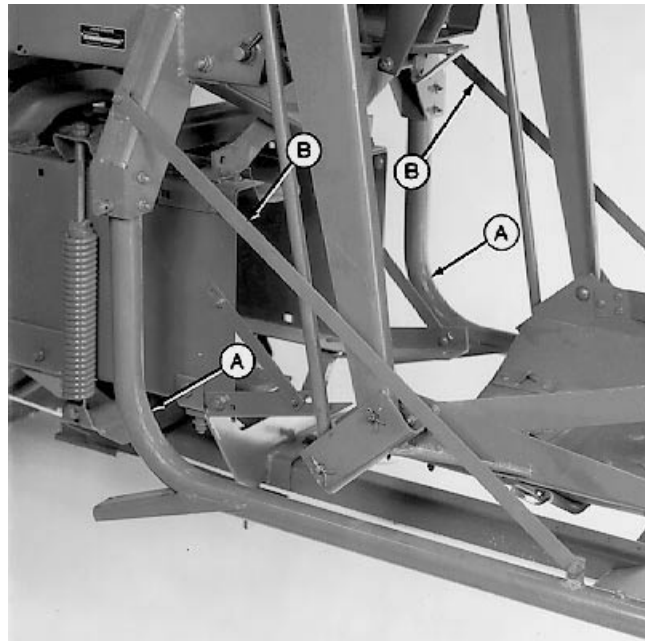

OME,42BE,ASY,M -19-26OCT94

E38241
-UN-13OCT94

30. Install right-hand (A) and left-hand (B) trip extension as shown. Snug down, do not tighten, set screws (C).

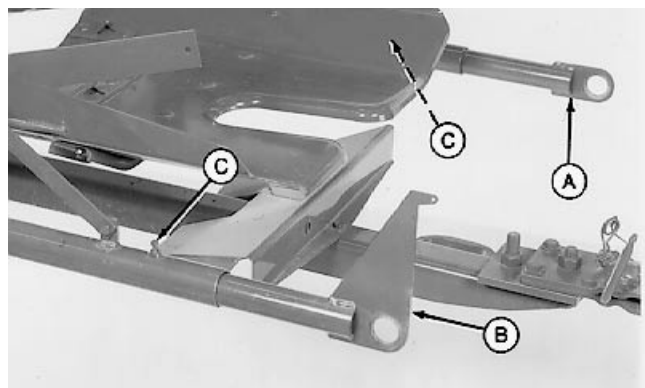

OME,42BE,ASY,N -19-26OCT94

E38242
-UN-13OCT94

31. Install pedal shaft (A) through right-hand extension (B) and left-hand extension (C) using one (1) 1-9/32 x 1-11/16 x 0.060-in. washer (D) between bracket on pedal shaft and left-hand extension.

IMPORTANT: Pedal shaft must rotate freely, with minimal lateral movement.

32. Add washers at positions (E) and (F) as needed. Install remaining washers at position (G).

33. Install 4 x 40-mm cotter pins at positions (H). Check to ensure the pedal shaft rotates freely.

- A—Trip Tube
- B—Right-Hand Extension
- C—Left-Hand Extension
- D—Washer
- E—Position (Washers)
- F—Position (Washers)
- G—Position (Washers)
- H—Position (Cotter Pins)

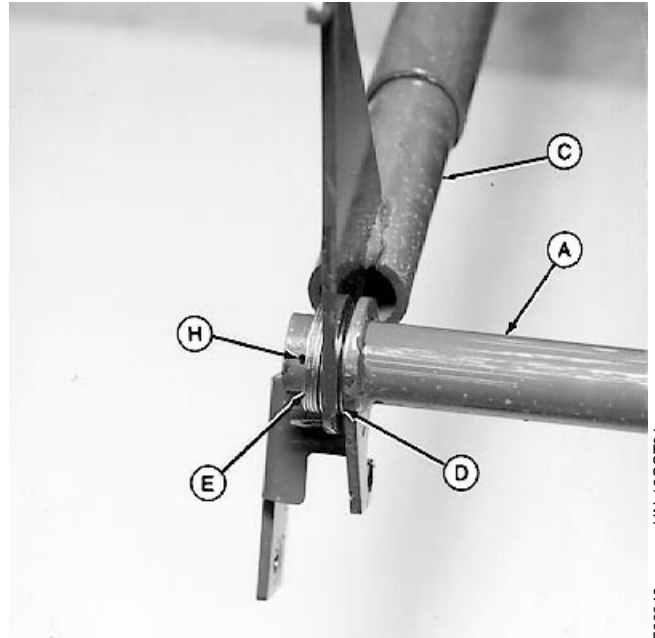

E38243 -UN-13OCT94

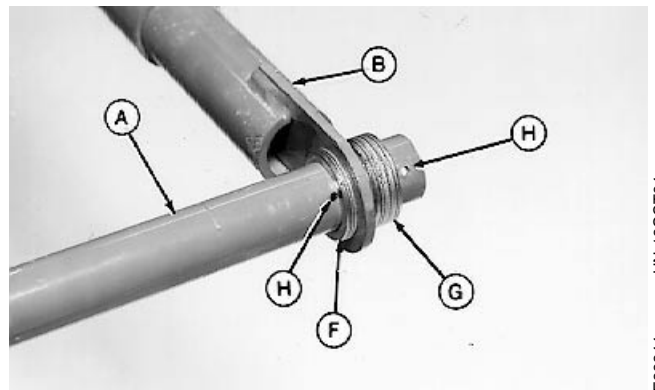

E38244 -UN-13OCT94

OME,42BE,ASY,O -19-26OCT94

Assembly

34. Install 3/8 x 1-1/4-in. cap screw (A) with two serrated flange head nuts, as shown.

35. Install 3/8 x 1-3/4-in. round head bolt (B) with two serrated flange nuts, as shown.

36. Install 19 mm (0.75 in) OD x 97mm (3.81 in) spring (C), as shown.



E38245
-JUN-13OCT94

OME,42BE,ASY,Q -19-26OCT94

37. Install 0.60 x 0.781 x 1-1/4-in. washer (B), trip lever (A), 1/4 x 1-1/4-in. spring pin (C) on trip lever pivot shaft.

38. Install a piece of shipping wire (D) through the spring pin and twist the ends as shown.

A—Trip Lever
B—Washers
C—Spring Pin
D—Wire

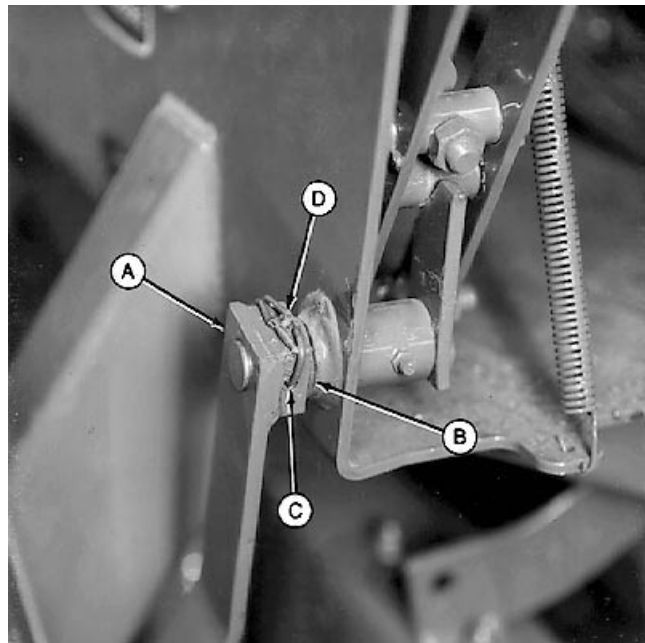

E38246
-JUN-13OCT94

OME,42BE,ASY,R -19-26OCT94

IMPORTANT: Install stud (G) with hole (H) parallel with bottom edge of trip lever (E).

39. Install stud (G) on trip lever (E) using serrated flange nut (F).

40. Install 0.312 x 0.742 ID spacer (D), 0.063 x 13/32 x 1-in. washer (C), and plastic knob (B) on stud.

41. Install 3/8-in. lock nut (A) on shaft until 1-1/2 to 2 threads extend beyond end of lock nut.

- A—Lock Nut
- B—Knob
- C—Washer
- D—Spacer
- E—Trip Lever
- F—Flange Nut
- G—Stud
- H—Hole

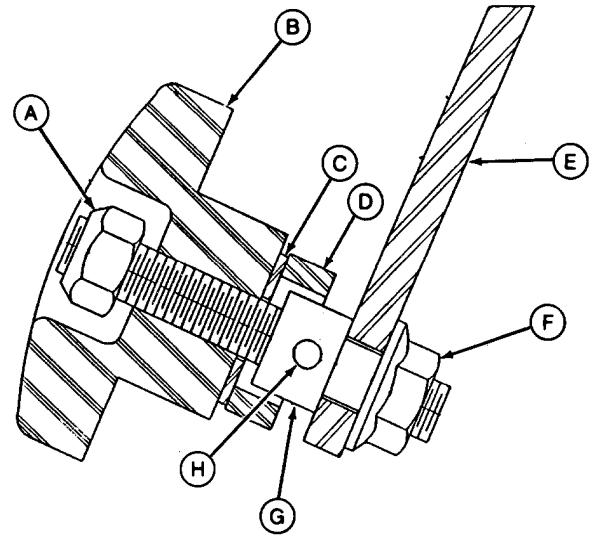

OME,42BE,ASY,S -19-26OCT94

42. Assemble 22 mm (0.85 in) OD x 97 mm (3.81 in) spring (A) to clevis (B) on trip cable using 1/4 x 3/4 cap screw (C) and lock nut.

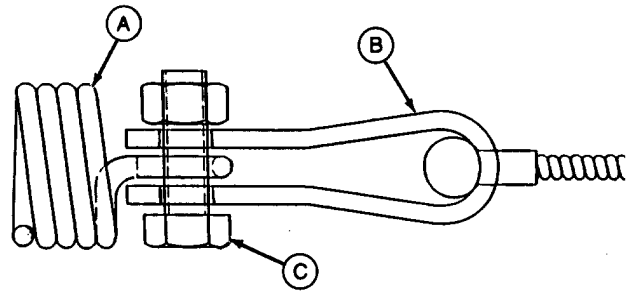

OME,42BE,ASY,T -19-26OCT94

Assembly

43. Install spring (A) ,assembled to trip cable (C), on lower cap screw (B).

NOTE: Do not tighten trip cable (C) at this time.

44. Thread trip cable (C) through hole in stud (D), as shown, on trip lever. Tighten knob enough so that spacer (E) will hold cable in position.

- A—Spring
- B—Cap Screw
- C—Trip Cable
- D—Stud
- E—Spacer

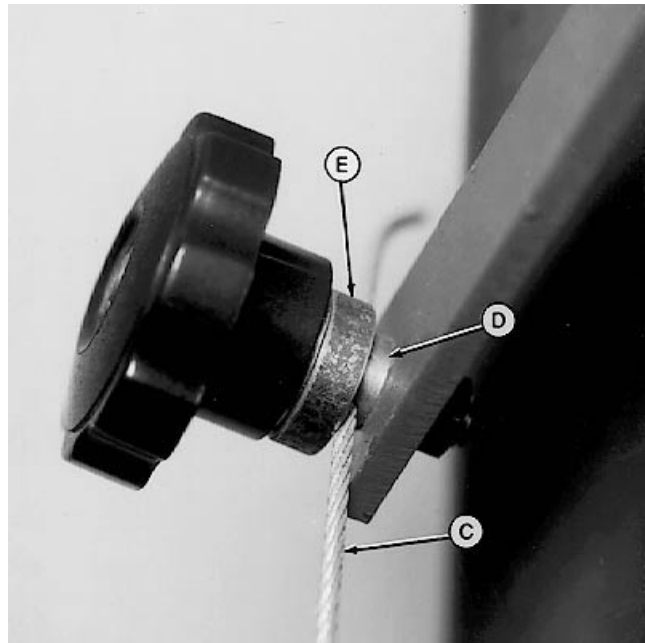
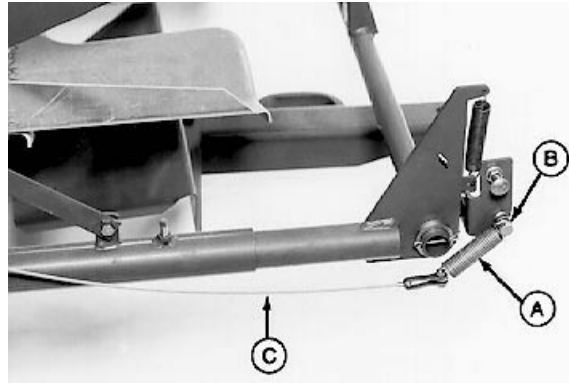

OME,42BE,ASY,U -19-26OCT94

IMPORTANT: The guides (D) must straddle the right-hand frame side sheet.

45. Install upper latch frame (A) through right-hand slot (B) and left-hand slot (C) in the frame.

46. Pivot the upper latch frame forward allowing it to rest on the baler, as shown.

- A—Upper Latch Frame
- B—Right-Hand Slot
- C—Left-Hand Slot
- D—Guides

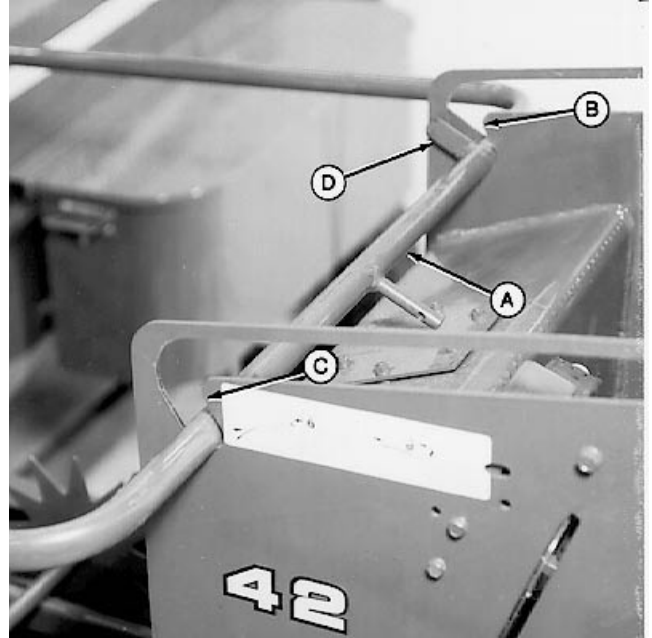

OME,42BE,ASY,V -19-26OCT94

47. Install guard rail (A) on pins welded to the right and left-hand side of the bale ejector frame, using 0.090 x 21/32 x 1-5/16 in. washer and cotter pin.

48. Pivot the guard rail straight up and install springs (B) on the right and left-hand side of the machine, as shown.

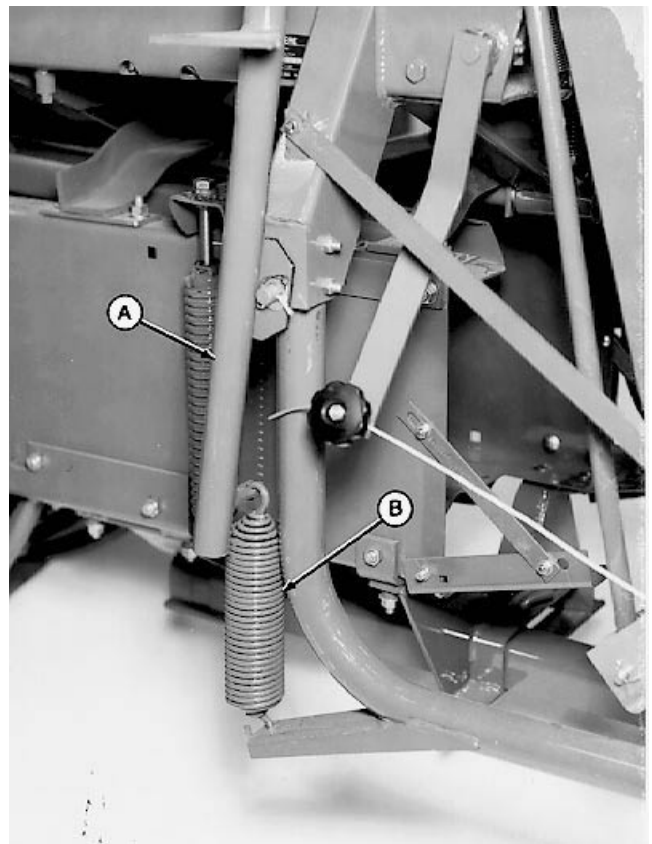

OME,42BE,ASY,W -19-26OCT94

CAUTION: To prevent bodily injury, it may be necessary to use a second person when performing Steps 47—49, to help with the spring loaded guard rail.

49. Pivot the guard rail (B) down parallel with the ground.

50. Pivot the upper latch frame (A) rearward and install 3/8 x 1/2-in. spacer (C) through brackets on guard rail and upper latch frame.

NOTE: When tightened, the washers should be against the edge of the spacer and the guard rail-upper latch assembly move freely.

51. Install 3/8 x 3/4-in. cap screw (D) and washer through spacer. Install washer and lock nut (E).

- A—Upper Latch Frame
- B—Guard Rail
- C—Spacer
- D—Cap Screw
- E—Lock Nut

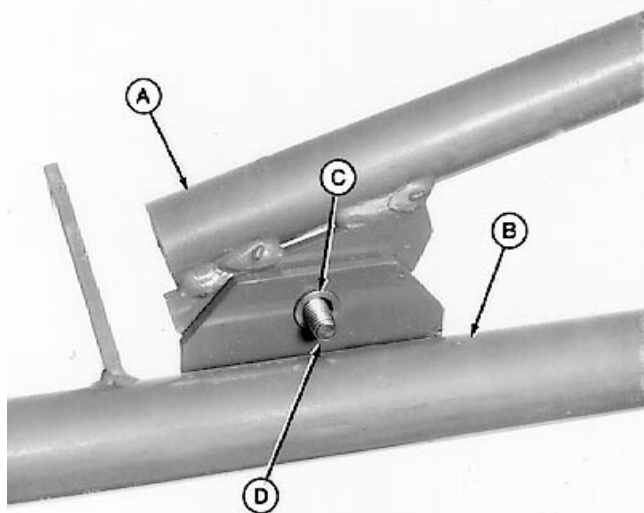

Left-Hand Side

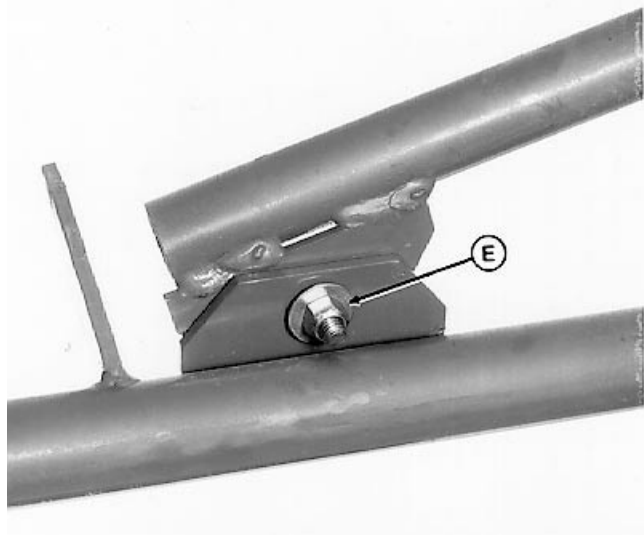

Left-Hand Side

OME,42BE,ASY,X -19-26OCT94

52. Position upper latch frame (A) in the operating position (B).

53. Install handle (C) using 1/4 x 1-1/2-in. cap screw (D) and lock nut.

- A—Upper Latch Frame
- B—Operation Position
- C—Handle
- D—Cap Screw

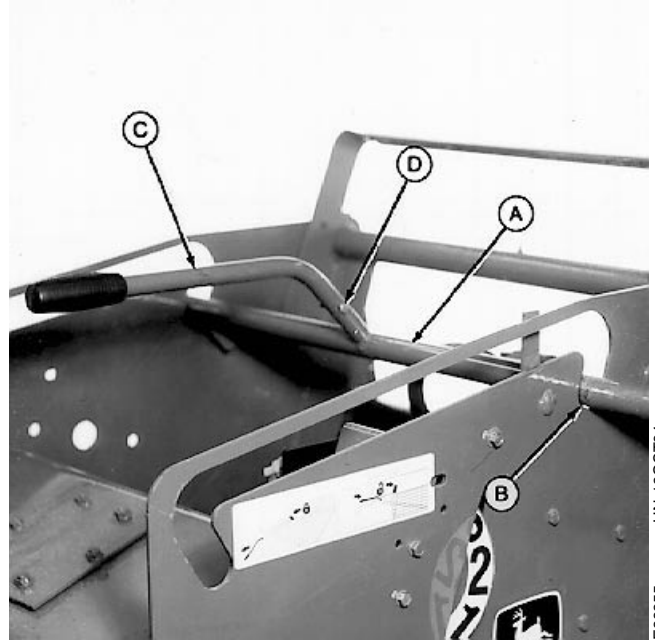

E38255 -UN-13OCT94

OME,42BE,ASY,Y -19-26OCT94

NOTE: Throwing shield with reflective tape (A) must be on left-hand side of machine.

54. Install left-hand (B) throwing shield, using four 1/4 x 1-in. round-head bolts (C), 9/32 x 5/8 x 0.060-in. washers and nut.

55. Install right-hand throwing shield (D).

- A—Reflective Tape
- B—Left—Hand Throwing Shield
- C—Round—Head Bolt
- D—Right—Hand Throwing Shield

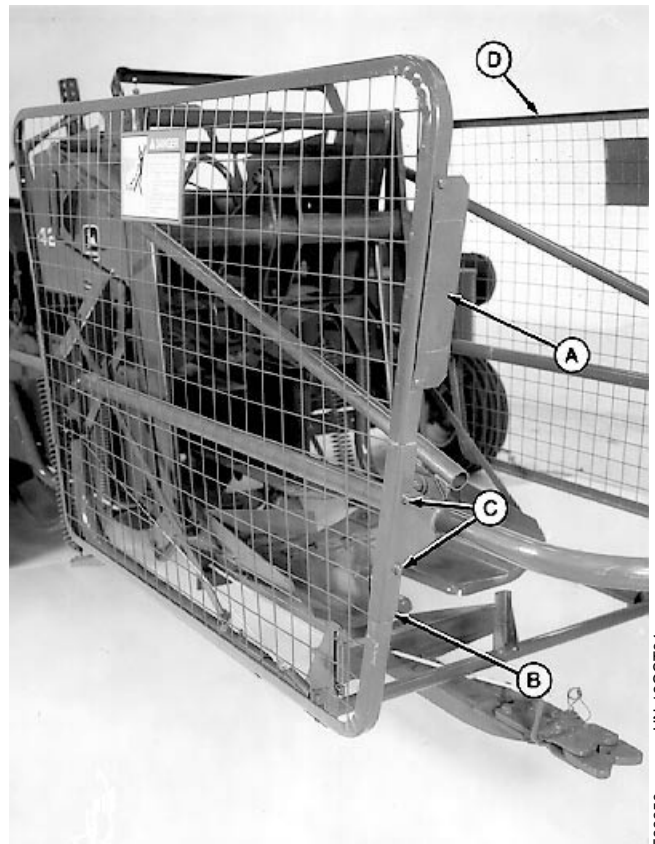

E38256 -UN-13OCT94

OME,42BE,ASY,Z -19-26OCT94

INSTALL HYDRAULIC PUMP ASSY

1. Remove support angle from basic ejector. Install angle (A) on 1/2 x 8-1/2-in. cap screw. Install jam nut on cap screw. Thread cap screw into spring plug.
2. Attach spring (B) to short stub on idler arm.
3. Fasten Idler arm to pulley with 1/2 x 5-1/2-in. cap screw (C), two 17/32 x 1-1/4 x 0.105-in. washers and nut.

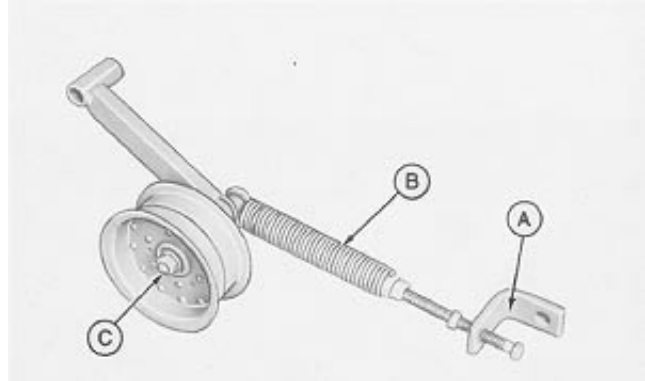

OME,42BE,ASY,AA-19-26OCT94

E24583 -UN-22AUG89

4. Attach support (A) to bale case. Fasten with 3/8 x 1-in. cap screw, 3/8 x 7/16-in. spacer, 13/32 x 1 x 0.060-in. washer, and nut
5. Attach idler arm (B) to bale case. Fasten with 1/2 x 3-1/2-in. cap screw, 3/4 x 2-1/2 x 0.109-in. bushing, 17/32 x 1-1/4 x 0.105-in. washer, and nut (C).

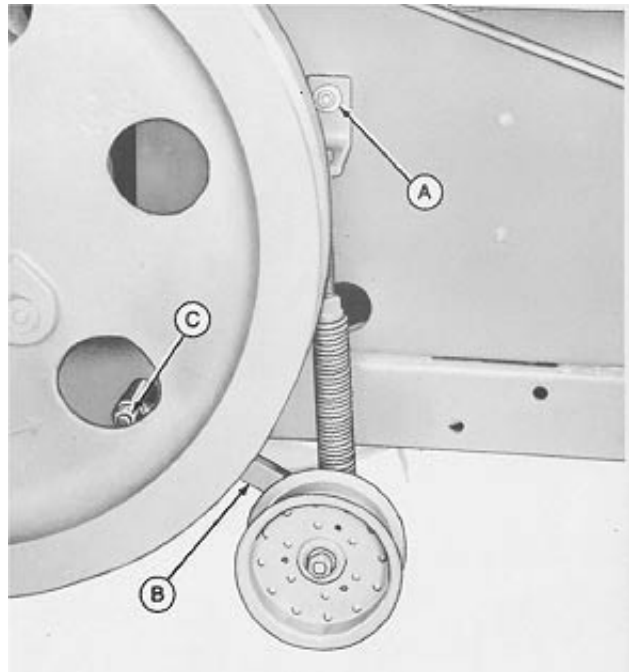

OME,42BE,ASY,AB-19-26OCT94

E24584 -UN-22AUG89

10. Remove paint from bore of pump sheave (A). Install sheave and fasten with key and existing hardware. Tighten nut to 115 N·m (85 lb-ft).



OME,42BE,ASY,AC-19-26OCT94

E29301 -UN-07DEC89

Assembly

11. Install two pump V-belts (A).
12. Adjust belts. (See Adjusting Pump Drive Belts in Service section.)
13. Install three U-nuts (B).
14. Bend shield support (C) to clear flywheel by 1.6 to 3.2 mm (1/16 to 1/8-in).

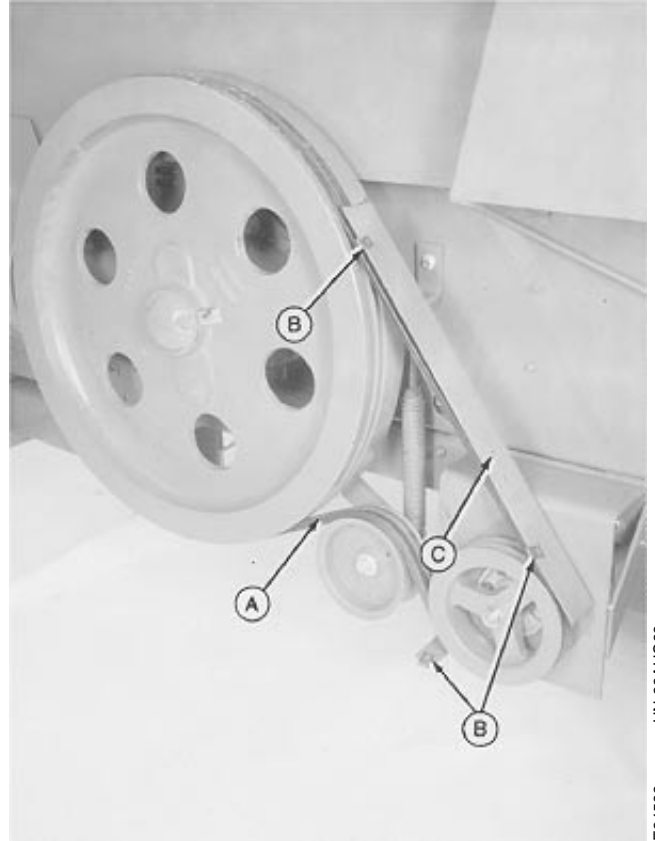

E24588 -UN-22AUG89

OME,42BE,ASY,AD-19-26OCT94

19. If electric controls are to be installed, fasten hose clamp (A) to support with nut and tighten.
20. Install plastic tie (B) on hydraulic lines.

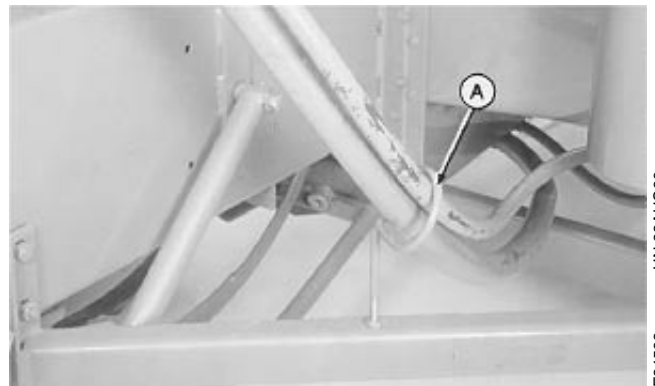

E24593 -UN-22AUG89

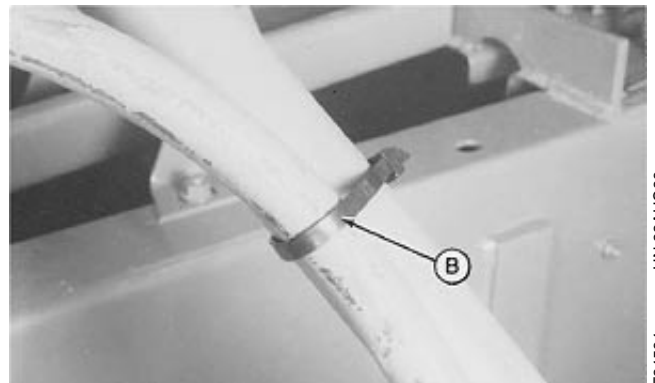

E24594 -UN-22AUG89

OME,42BE,ASY,AH-19-26OCT94

INSTALL HYDRAULIC CYLINDER

⚠ CAUTION: Block the ejector securely to avoid accidental tipping.

1. Install cylinder support (A) to wagon hitch support. Fasten with two 7/16 x 1-1/4-in. cap screws and nuts.
2. (Not illustrated) Remove three cap screws, nuts, and stationary link.
3. Install cylinder support (B). Fasten with two 1/2 x 1-in. cap screws and nuts.
4. Install cylinder. Fasten with pins and spring pins.

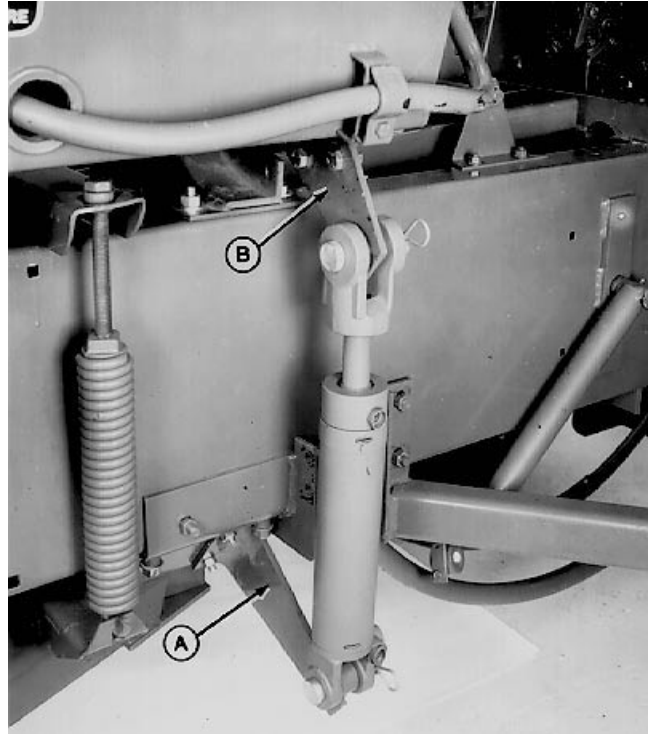

E38257
-UN-13OCT94

OME,42BE,ASY,AI-19-26OCT94

5. Attach 1270 mm (50-in.) hoses to tubes with 3/4-in. O-ring, coupler, and 3/4-in. O-ring to 9/16-in. flare fitting.
6. Assemble tubes, brackets and hoses as shown.
7. Route hydraulic lines along right-hand side of baler and to front of machine.

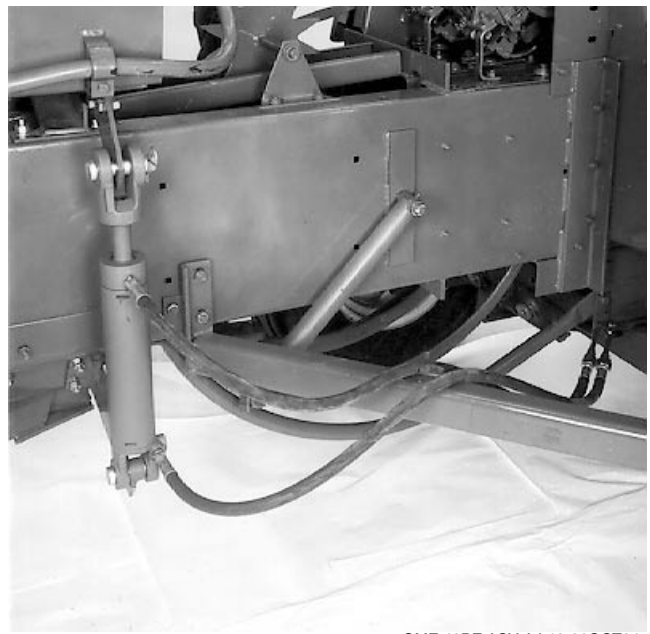

E38258
-UN-13OCT94

OME,42BE,ASY,AJ-19-26OCT94

Assembly

8. Install brackets (A) to baler with 1/2 x 1-in. round-head bolt (B) and nut. Fasten tubes to tube clamp. Attach clamp to bracket with 3/8 x 1-in. cap screw and nut.

9. Attach two adapters (C) to baler with two 3/4-in. jam nuts.

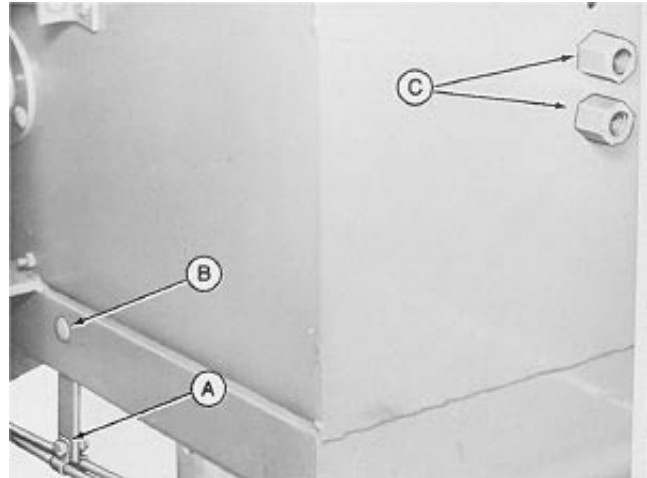

E24601 -UN-29AUG89

OME,42BE,ASY,AK-19-26OCT94

10. Attach two elbows (A) to adapters.

11. Attach tubes (B) to elbows.

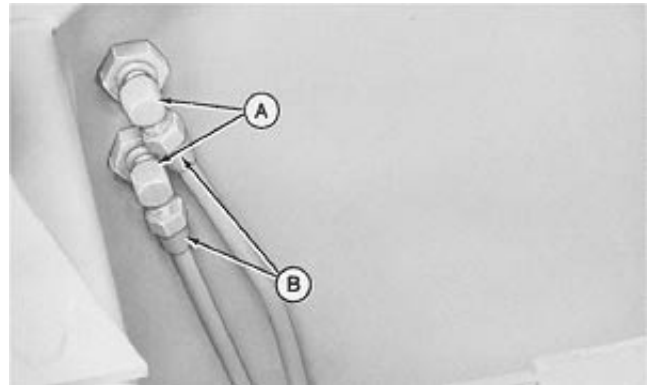

E24602 -UN-22AUG89

OME,42BE,ASY,AL-19-26OCT94

12. Attach spring (A) to baler with 1/2 to 1-in. cap screw.

13. Attach hose support (B) to spring with 1/2 x 1-in. cap screw.

14. Attach hoses (C) to clamps (D) and support with 5/16 x 1-1/4-in. bolt and nut.

A—Spring
B—Hose Support
C—Hoses
D—Clamps

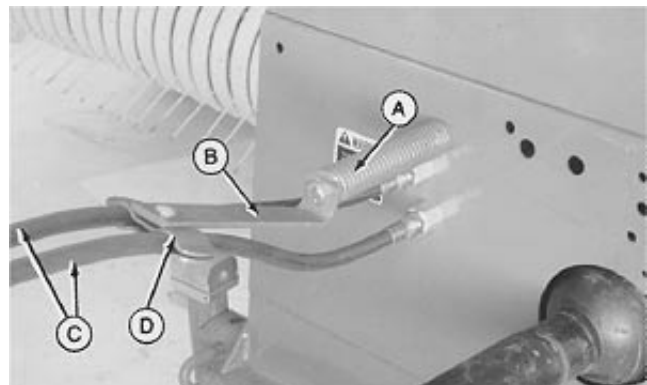

E24604 -UN-22AUG89

OME,42BE,ASY,AM-19-26OCT94

Assembly

15. Put O-ring on connector (A). Attach to hydraulic line and tighten.

16. Repeat on remaining hydraulic line.

17. Attach both hydraulic lines to PTO support. Fasten with plastic tie (B).

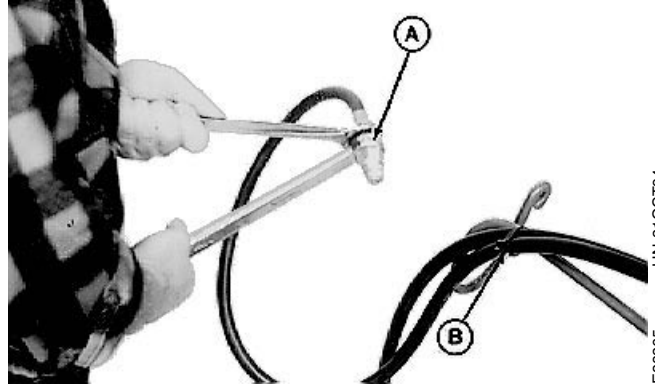

OME,42BE,ASY,AN-19-26OCT94

E38265 -UN-21OCT94

18. Fasten hydraulic lines to main frame with clamp (A), 3/8 x 1-1/2-in. round-head bolt, and lock nut.



OME,42BE,ASY,AO-19-26OCT94

E24605 -UN-22AUG89

19. Thread nut (A) to top of hose guide (B).

20. Install clamps (C), hoses, and nut. Tighten assembly.

21. Install spacer (D) on guide and install on brace (E). Fasten with nut.

- A—Nut
- B—Hose Guide
- C—Clamps
- D—Spacer
- E—Brace

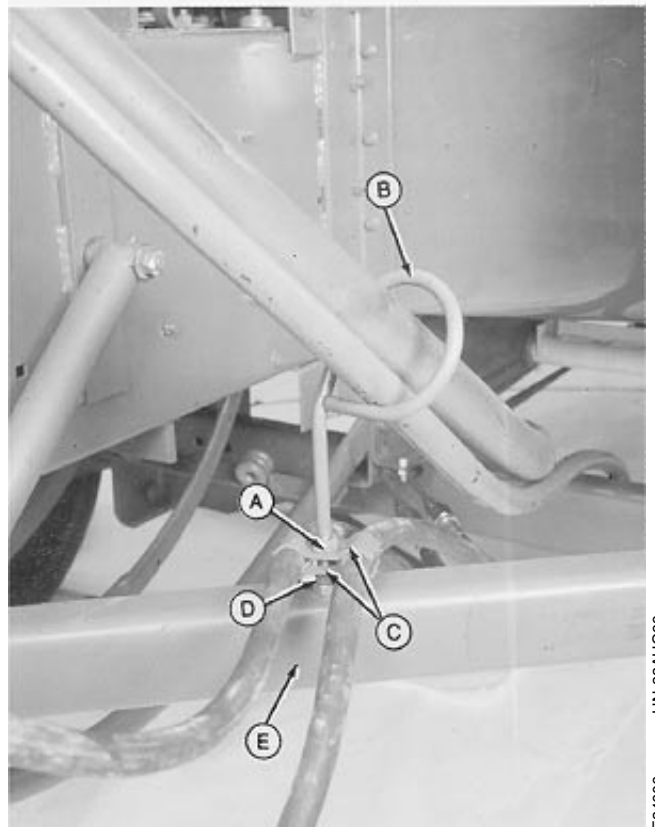

OME,42BE,ASY,AP-19-26OCT94

E24606 -UN-22AUG89

HYDRAULIC CYLINDER KIT

Install short hose extensions (A) and couplers (B), as shown, when used with 2840, 2940, 2950, or 3150 Tractors.

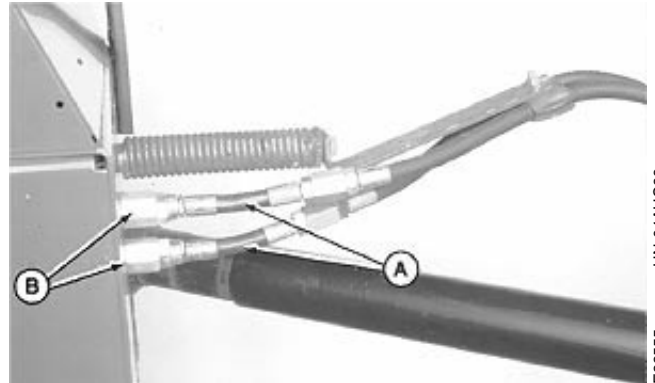

OME,42BE,ASY,AQ-19-26OCT94

-UN-04AUG89
E22555

INSTALL ELECTRIC CONTROLS—TILT ACTUATOR (OPTIONAL)

NOTE: See your John Deere dealer if wagon hitch is not equipped with bracket (B).

1. Install lower mounting brackets (A). Fasten with two 1/2 x 2-3/4-in. cap screws, spacers, and flanged nuts. Tighten hardware.

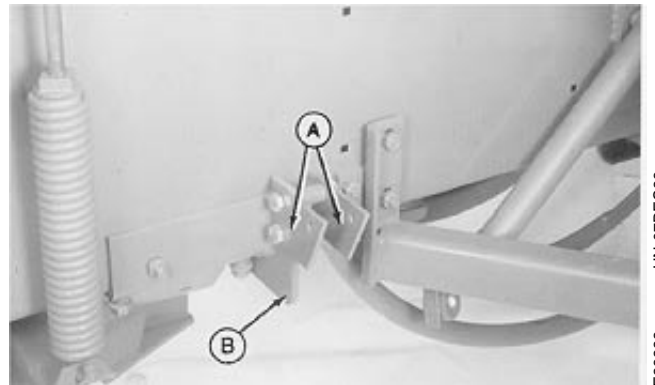

OME,42BE,ASY,AR-19-26OCT94

-UN-07DEC89
E29288

2. Put block of wood between ejector and bale case to keep ejector from accidentally tipping.

3. (Not illustrated.) Remove three cap screws, nuts, and stationary link, installed in step 21, Install Basic Ejector Assembly (All Balers) in this section.

4. Attach two brackets (A) to ejector. Fasten with two 1/2 x 2-3/4-in. cap screws (B), spacers, and flanged nuts. Do not tighten at this time.

5. Attach tilt actuator with drilled pin (C) and four 17/32 x 1 x 0.060-in. washers on each side of actuator.

6. If actuator (D) does not center between lower brackets (E), bend ejector frame where upper brackets attach to frame.

- A—Brackets
- B—Cap Screws
- C—Drilled Pin
- D—Actuator
- E—Lower Brackets

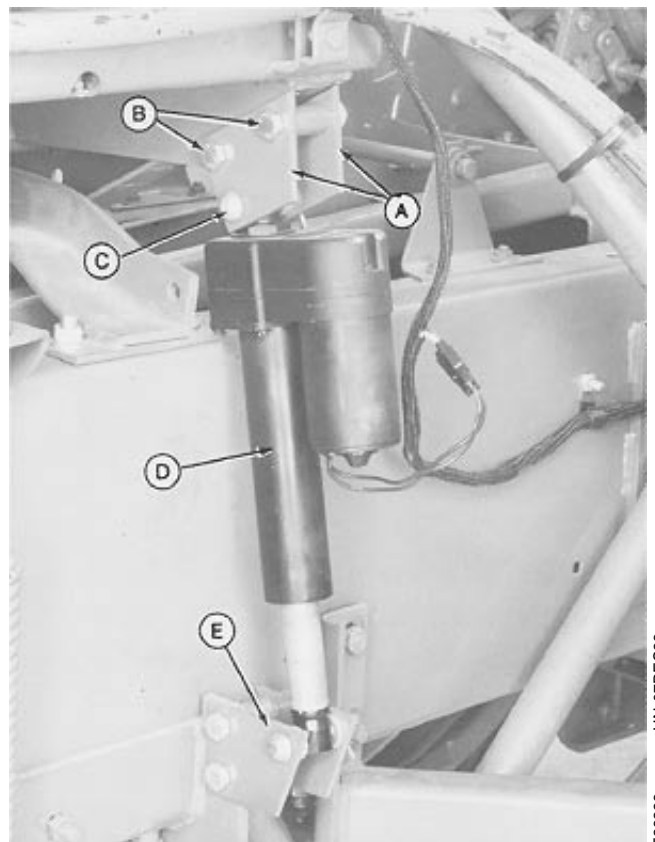

OME,42BE,ASY,AS-19-26OCT94

-UN-07DEC89
E29289

Assembly

7. Attach actuator (A). Fasten with drilled pin, 17/32 x 1 x 0.060-in. washers (B) and cotter pin (C).

8. Tighten top and bottom bolts.

9. Remove block of wood (D).

A—Actuator
B—Washers
C—Cotter Pin
D—Block of Wood

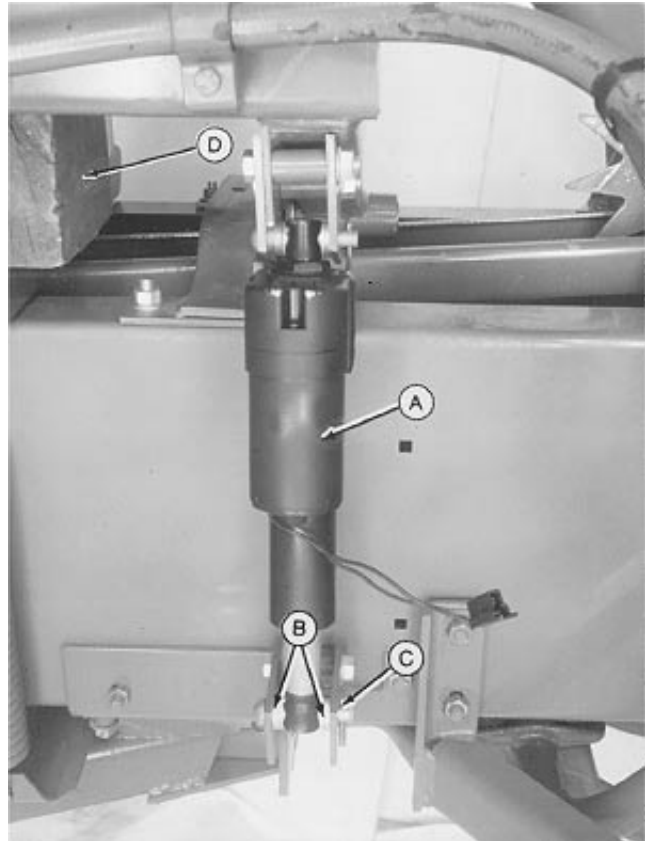

OME,42BE,ASY,AT-19-26OCT94

E29290 -UN-07DEC89

10. Loosely place grommet on wiring harness and route through hole (A) in tongue on baler.

11. Push grommet (B) into tongue.

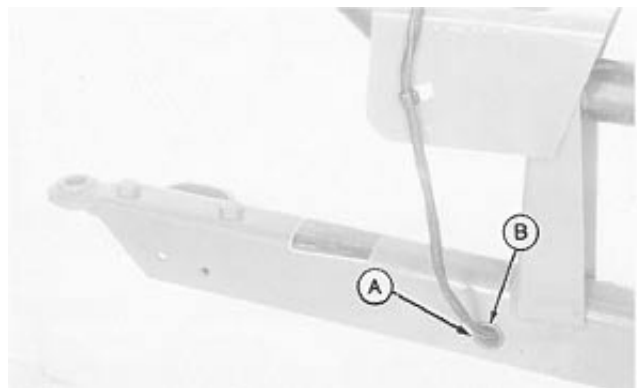

OME,42BE,ASY,AU-19-26OCT94

E29291 -UN-07DEC89

12. Pull harness (A) out through end of tongue.

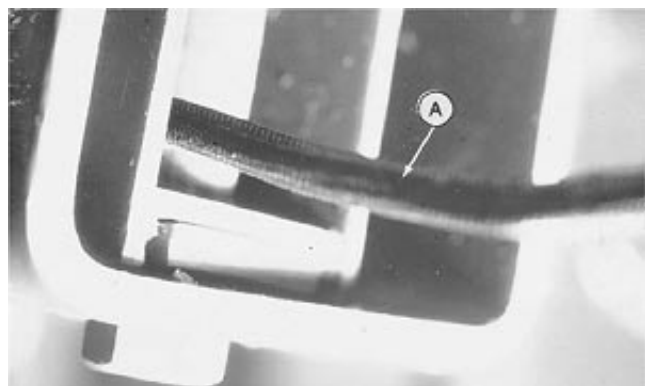

OME,42BE,ASY,AV-19-26OCT94

E24616 -UN-22AUG89

Assembly

13. Place two wiring clamps (A) on harness (B).

14. Fasten clamps (A) to baler frame with 5/16 X 3/4-in. cap screws and flanged nut (C). Do not tighten at this time.

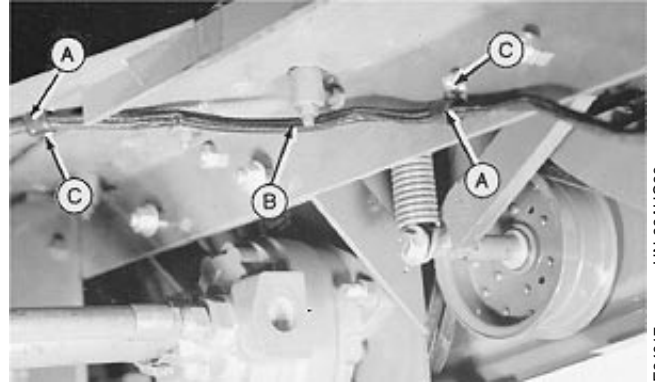

OME,42BE,ASY,AW-19-26OCT94

E24617
-UN-22AUG89

15. Route harness through slot (A) in frame.

16. Attach wiring clip (B) to baler frame with 5/16 x 3/4-in. round-head bolt and flanged nut. Do not tighten at this time.

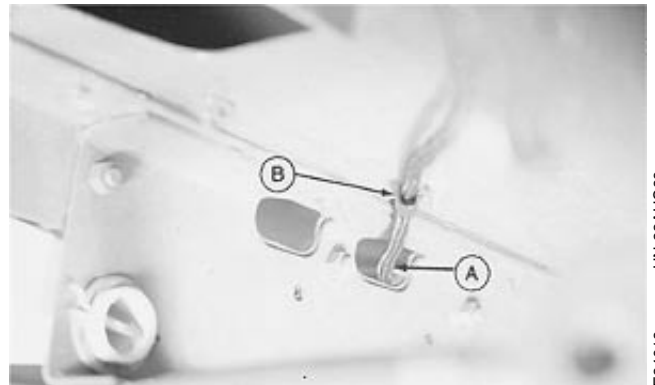

OME,42BE,ASY,AX-19-26OCT94

E24618
-UN-22AUG89

17. Route harness (A), as shown, with three clips (B), 5/16 x 3/4-in. round-head bolts, and flanged nuts. Do not tighten at this time.

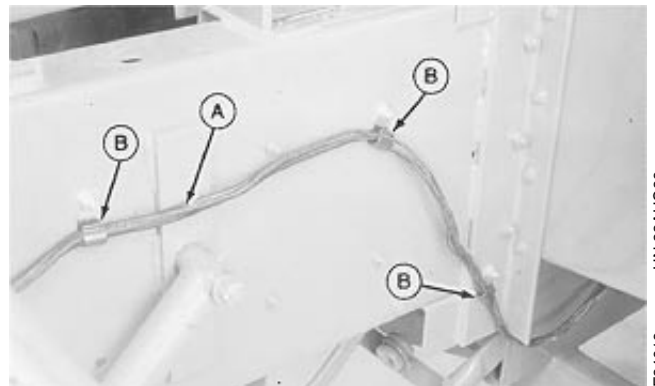

OME,42BE,ASY,AY-19-26OCT94

E24619
-UN-22AUG89

Assembly

18. Route harness through hole in ejector frame and under throwing cylinder (A).
19. Attach harness to motor (B).
20. Attach ground wire (C) with 1/4 x 1/2-in. cap screw.
21. Remove any slack in wiring harness. Install plastic tie (D) around harness and hydraulic hose.

A—Throwing Cylinder
B—Motor
C—Ground Wire
D—Plastic Tie

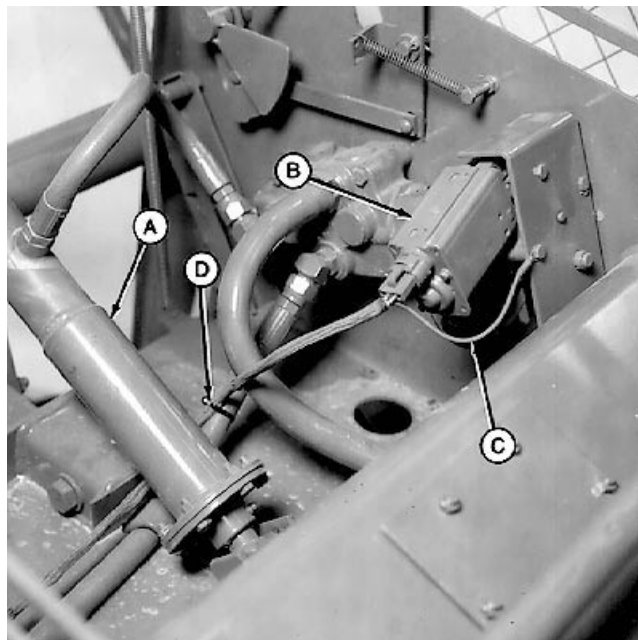

E38259
-JUN-13OCT94

OME,42BE,ASY,AZ-19-26OCT94

22. Attach electrical connector (A) to actuator.
23. Remove excess slack from wiring harness. Install plastic ties (B) around wiring harness and hydraulic hose.
24. (Not illustrated.) Follow route of harness and remove slack. Tighten wiring clips.

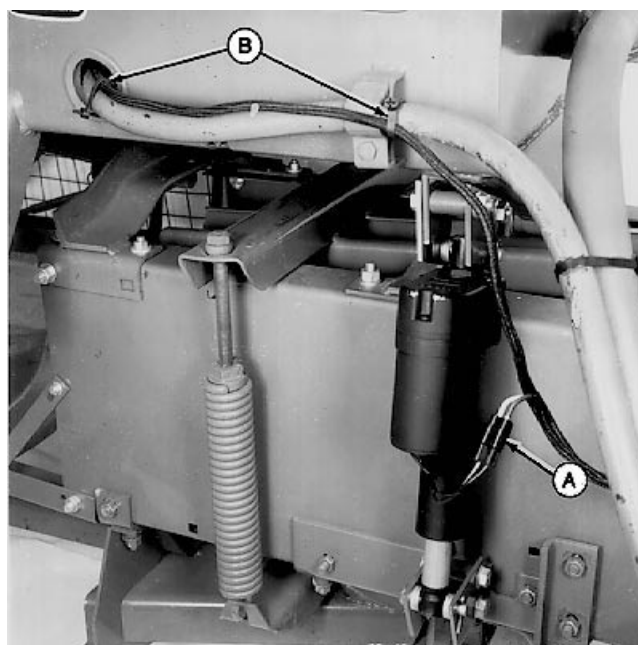

E38260
-JUN-13OCT94

OME,42BE,ASY,BA-19-26OCT94

Assembly

25. Attach wiring clip (A) to PTO shield. Fasten with 5/16 x 3/4-in. cap screw and flanged nut.

26. Route harness along PTO support. Install plastic ties (B).

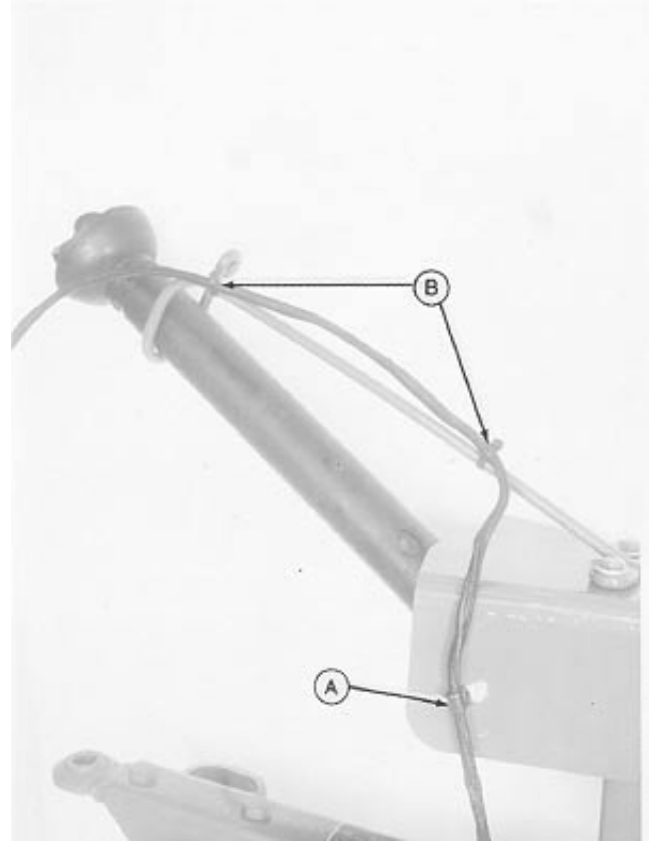

OME,42BE,ASY,BB-19-26OCT94

E24623 -UN-29AUG89

27. Put dust cover (A) on harness until ready for use.

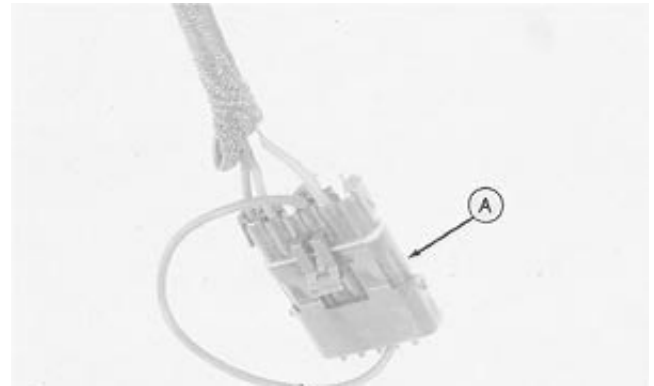

OME,42BE,ASY,BC-19-26OCT94

E24624 -UN-22AUG89

INSTALL WAGON HITCH RELEASE

NOTE: Hitch is shown in operating position and lockout pin (E) is in storage hole. (See Preparing the Bale Ejector section.)

1. Put bracket (A) and hitch (B) on tongue. Fasten with two 1/2 x 1-1/4-in. cap screws and 17/32 x 1-1/8 x 0.105-in. washers.
2. Install two 3/4 x 3-in. cap screws and lock nuts.
3. Install grommet (C) in tongue ramp.
4. Route rope (D) through hitch and grommet (C) as shown.

A—Bracket
 B—Hitch
 C—Grommet
 D—Rope
 E—Lockout Pin

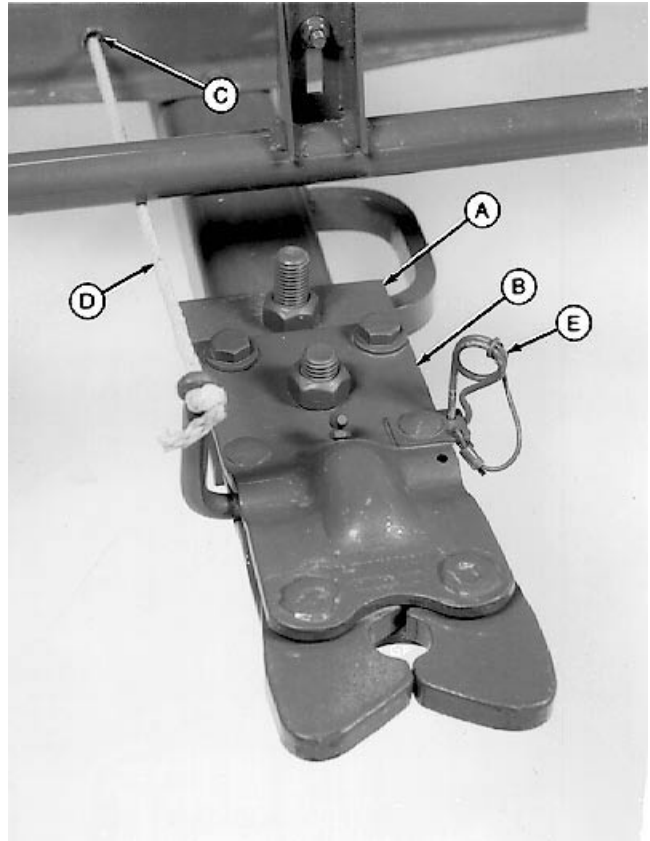

OME,42BE,ASY,BD-19-26OCT94

E38261 -UN-13OCT94

5. Install guide (A) below tongue reinforcement using 5/16 x 4-in. cap screw and nut.
6. Route rope (B) through guide.

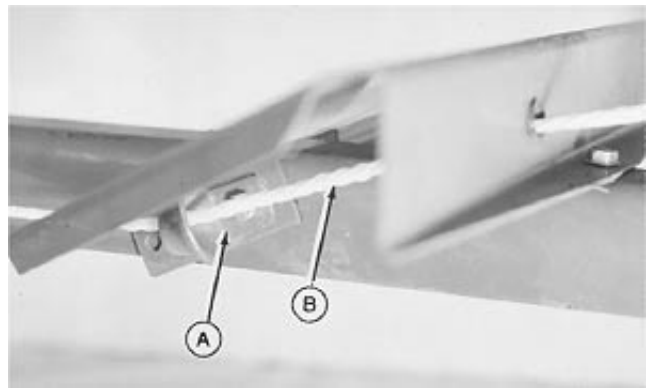

OME,42BE,ASY,BE-19-26OCT94

E24639 -UN-29AUG89

7. Put grommet (A) in hitch frame.
8. Remove round-head bolt, washer, and nut (B). Discard hardware.
9. Install 1/2 x 2-1/4-in. round-head bolt, washer, angle (C), and nut.
10. Install grommet. Route rope as shown.

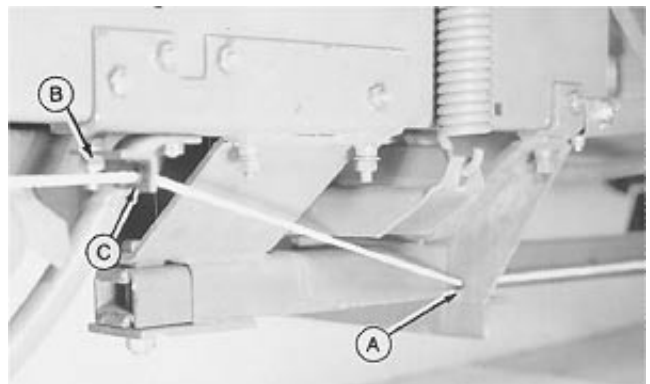

OME,42BE,ASY,BF-19-26OCT94

E24640 -UN-29AUG89

Assembly

11. Put grommets (A) in pump mounting and route rope through grommet.



OME,42BE,ASY,BG-19-26OCT94

E24641
-UN-29AUG89

NOTE: On earlier model balers that do not have a hole in frame, drill a 5/8-in. (16 mm) hole as shown.

- A—16 mm (5/8-in.) Hole
- B—51 mm (2-in.)
- C—83 mm (3-1/4 in.)

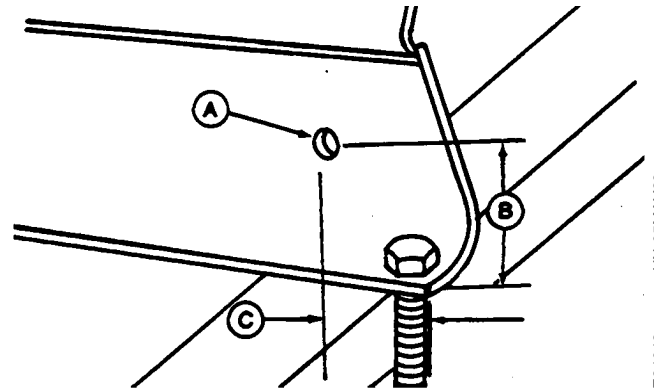

OME,42BE,ASY,BH-19-26OCT94

E24643
-UN-05MAY89

12. Put grommet (A) in hole above tongue of baler.
13. Place washer (B), spring (C), and washer on rope.
14. Compress spring to approximately 76 mm (3-in.) (D). Put a knot (E) at this location.

- A—Grommet
- B—Washer
- C—Spring
- D—76 mm (3 in.)
- E—Knot

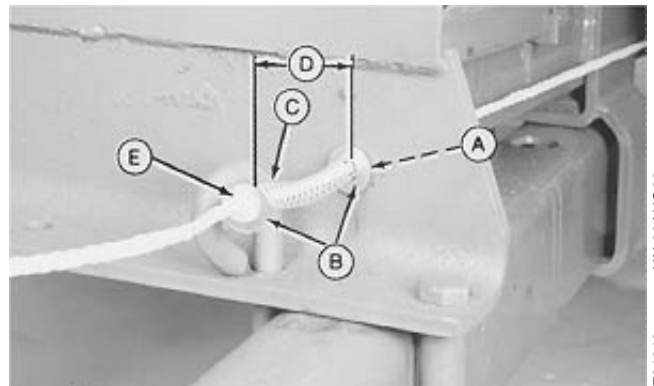

OME,42BE,ASY,BI-19-26OCT94

E24642
-UN-29AUG89

15. Attach J-clamp and insulator (A) to right-hand side of pedestal shield. Fasten with lock nut.

16. Allow enough rope to reach from tractor seat to baler. Tie knot in rope at approximate location for handle (B). Put handle on rope and fasten with knot. Remove excess rope.

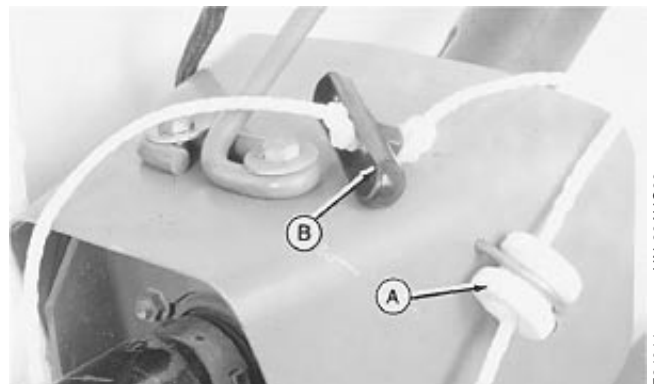

OME,42BE,ASY,BJ-19-26OCT94

E24644
-UN-29AUG89

Assembly

12. Put grommet (A) in hole above tongue of baler.
13. Place washer (B), spring (C), and washer on rope.
14. Compress spring to approximately 76 mm (3-in.) (D). Put a knot (E) at this location.

A—Grommet
B—Washer
C—Spring
D—76 mm (3 in.)
E—Knot

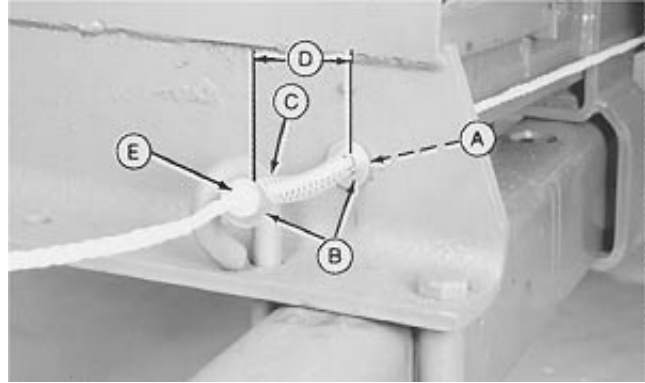

OME,42BE,ASY,BK-19-27JUN94

-UN-29AUG89
E24642

15. Attach J-clamp and insulator (A) to right-hand side of pedestal shield. Fasten with lock nut.
16. Allow enough rope to reach from tractor seat to baler. Tie knot in rope at approximate location for handle (B). Put handle on rope and fasten with knot. Remove excess rope.

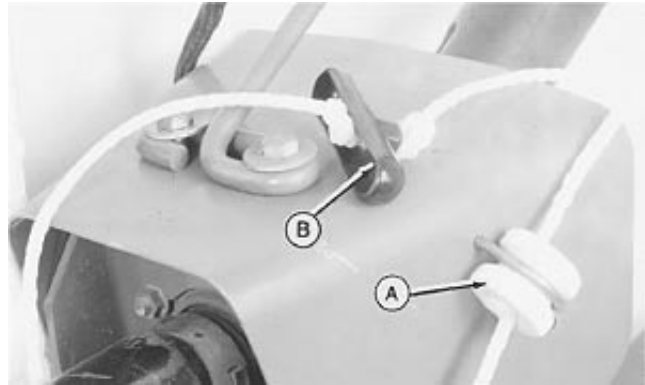

OME,42BE,ASY,BL-19-27JUN94

-UN-29AUG89
E24644

Specifications

Bale: Cross section 14 in. x 18 in. (360 mm x 460 mm)
Length (Approximately) 27 in. to 38 in. (690 mm to 965 mm)
Bale Weight (Varies with condition of hay) 80 lbs (36 kg) maximum
Baler Works with John Deere 336, 346, 327, 337, 347, 328, 338 and 348 Balers
Capacity Equal to baler
Height (above bale case top) (Approximately) 31 in. (787 mm)
Hydraulic system capacity 8.5 U.S. gal (32.2 L)
Length (beyond end of bale case) (Approximately) 68 in. (1730 mm)
Weight of ejector (with wagon hitch) (Approximately 600 lb (272 kg)
Source of power Hydraulic pump, belt driven from baler flywheel

(Specifications and design subject to change without notice.)

OME,42BE,SPEC,A-19-26OCT94

RECORD SERIAL NUMBER

When ordering parts, always furnish the model and serial number as given on the serial number plate.

Record serial number in the space provided.



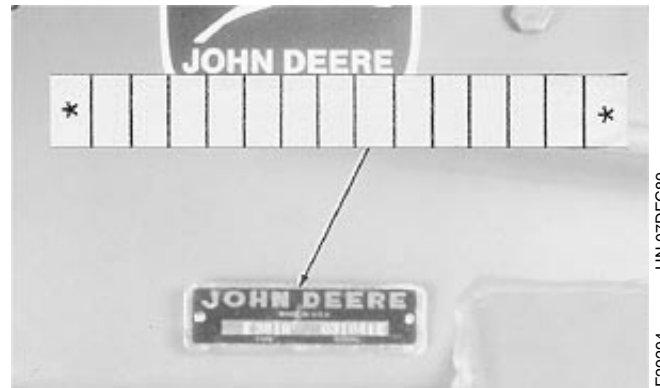







The bale ejector serial number is located on the left side of the main frame.



-JUN-07DEC89
E29294

OME,42BE,SPEC,B-19-26OCT94

UNIFIED INCH BOLT AND CAP SCREW TORQUE VALUES

SAE Grade and Head Markings	1 or 2 ^b	5	5.1	5.2	8	8.2
	NO MARK 					
SAE Grade and Nut Markings	2	5		8		
	NO MARK 					

TS1162 -19-04/MAR/01

Size	Grade 1				Grade 2 ^b				Grade 5, 5.1, or 5.2				Grade 8 or 8.2			
	Lubricated ^a		Dry ^a		Lubricated ^a		Dry ^a		Lubricated ^a		Dry ^a		Lubricated ^a		Dry ^a	
	N-m	lb-ft	N-m	lb-ft	N-m	lb-ft	N-m	lb-ft	N-m	lb-ft	N-m	lb-ft	N-m	lb-ft	N-m	lb-ft
1/4	3.7	2.8	4.7	3.5	6	4.5	7.5	5.5	9.5	7	12	9	13.5	10	17	12.5
5/16	7.7	5.5	10	7	12	9	15	11	20	15	25	18	28	21	35	26
3/8	14	10	17	13	22	16	27	20	35	26	44	33	50	36	63	46
7/16	22	16	28	20	35	26	44	32	55	41	70	52	80	58	100	75
1/2	33	25	42	31	53	39	67	50	85	63	110	80	120	90	150	115
9/16	48	36	60	45	75	56	95	70	125	90	155	115	175	130	225	160
5/8	67	50	85	62	105	78	135	100	170	125	215	160	240	175	300	225
3/4	120	87	150	110	190	140	240	175	300	225	375	280	425	310	550	400
7/8	190	140	240	175	190	140	240	175	490	360	625	450	700	500	875	650
1	290	210	360	270	290	210	360	270	725	540	925	675	1050	750	1300	975
1-1/8	400	300	510	375	400	300	510	375	900	675	1150	850	1450	1075	1850	1350
1-1/4	570	425	725	530	570	425	725	530	1300	950	1650	1200	2050	1500	2600	1950
1-3/8	750	550	950	700	750	550	950	700	1700	1250	2150	1550	2700	2000	3400	2550
1-1/2	1000	725	1250	925	990	725	1250	930	2250	1650	2850	2100	3600	2650	4550	3350

DO NOT use these values if a different torque value or tightening procedure is given for a specific application. Torque values listed are for general use only. Check tightness of fasteners periodically.

Fasteners should be replaced with the same or higher grade. If higher grade fasteners are used, these should only be tightened to the strength of the original.

Shear bolts are designed to fail under predetermined loads. Always replace shear bolts with identical grade.

Make sure fasteners threads are clean and that you properly start thread engagement. This will prevent them from failing when tightening.

Tighten plastic insert or crimped steel-type lock nuts to approximately 50 percent of the dry torque shown in the chart, applied to the nut, not to the bolt head. Tighten toothed or serrated-type lock nuts to the full torque value.

^a "Lubricated" means coated with a lubricant such as engine oil, or fasteners with phosphate and oil coatings. "Dry" means plain or zinc plated without any lubrication.

^b Grade 2 applies for hex cap screws (not hex bolts) up to 152 mm (6-in.) long. Grade 1 applies for hex cap screws over 152 mm (6-in.) long, and for all other types of bolts and screws of any length.

METRIC BOLT AND CAP SCREW TORQUE VALUES

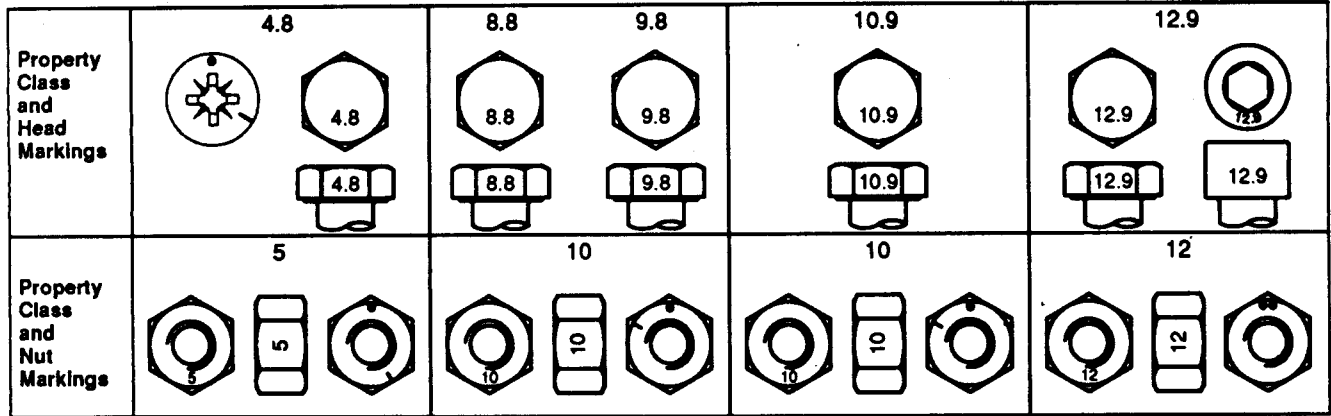

TS1163 -19-04MAR91

Size	Class 4.8				Class 8.8 or 9.8				Class 10.9				Class 12.9			
	Lubricated ^a		Dry ^a		Lubricated ^a		Dry ^a		Lubricated ^a		Dry ^a		Lubricated ^a		Dry ^a	
	N-m	lb-ft	N-m	lb-ft	N-m	lb-ft	N-m	lb-ft	N-m	lb-ft	N-m	lb-ft	N-m	lb-ft	N-m	lb-ft
M6	4.8	3.5	6	4.5	9	6.5	11	8.5	13	9.5	17	12	15	11.5	19	14.5
M8	12	8.5	15	11	22	16	28	20	32	24	40	30	37	28	47	35
M10	23	17	29	21	43	32	55	40	63	47	80	60	75	55	95	70
M12	40	29	50	37	75	55	95	70	110	80	140	105	130	95	165	120
M14	63	47	80	60	120	88	150	110	175	130	225	165	205	150	260	190
M16	100	73	125	92	190	140	240	175	275	200	350	255	320	240	400	300
M18	135	100	175	125	260	195	330	250	375	275	475	350	440	325	560	410
M20	190	140	240	180	375	275	475	350	530	400	675	500	625	460	800	580
M22	260	190	330	250	510	375	650	475	725	540	925	675	850	625	1075	800
M24	330	250	425	310	650	475	825	600	925	675	1150	850	1075	800	1350	1000
M27	490	360	625	450	950	700	1200	875	1350	1000	1700	1250	1600	1150	2000	1500
M30	675	490	850	625	1300	950	1650	1200	1850	1350	2300	1700	2150	1600	2700	2000
M33	900	675	1150	850	1750	1300	2200	1650	2500	1850	3150	2350	2900	2150	3700	2750
M36	1150	850	1450	1075	2250	1650	2850	2100	3200	2350	4050	3000	3750	2750	4750	3500

DO NOT use these values if a different torque value or tightening procedure is given for a specific application. Torque values listed are for general use only. Check tightness of fasteners periodically.

Shear bolts are designed to fail under predetermined loads. Always replace shear bolts with identical property class.

Fasteners should be replaced with the same or higher property class. If higher property class fasteners are used, these should only be tightened to the strength of the original.

^a "Lubricated" means coated with a lubricant such as engine oil, or fasteners with phosphate and oil coatings. "Dry" means plain or zinc plated without any lubrication.

Make sure fasteners threads are clean and that you properly start thread engagement. This will prevent them from failing when tightening.

Tighten plastic insert or crimped steel-type lock nuts to approximately 50 percent of the dry torque shown in the chart, applied to the nut, not to the bolt head. Tighten toothed or serrated-type lock nuts to the full torque value.

Crime Prevention Tips

HELP PREVENT CRIME

You can help take a bite out of crime by properly documenting ownership and discouraging theft.

TAKE A BITE OUT OF
CRIME
© 1979 The Advertising Council, Inc.



DX,CRPRV,A -19-03MAR93

TS140 -19-07OCT88

RECORD IDENTIFICATION NUMBERS

1. Mark your machines with your own unique numbering system.
2. Record the Product Identification Number (PIN) of the unit and also individual component identification numbers for engines, axles, pumps, etc. Include the PIN numbers on all documentation, such as insurance, financial, and warranty papers.

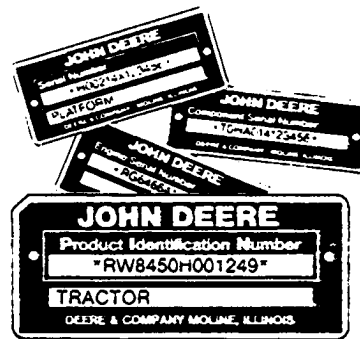

DX,CRPRV,B -19-03MAR93

TS161 -UN-23MAR89

KEEP PROOF OF OWNERSHIP

1. Take color photographs from several angles of each machine.
2. Maintain an up-to-date inventory of all your machines.
3. Keep your documented identification numbers, color photographs, and inventory in a safe, secure location.

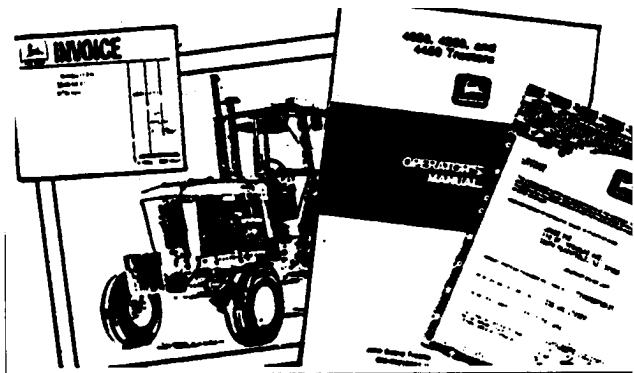

DX,CRPRV,C -19-03MAR93

TS142 -UN-23MAR89

PARK INDOORS OUT OF SIGHT

Make machines hard to move:

- Park large equipment in front of exits.
- Lower equipment to the ground. Remove key.
- Remove battery when unit is in storage.
- Lock cab doors, windows, and vandal-proof devices.
- Set wheels in widest position making loading more difficult. Lock building.

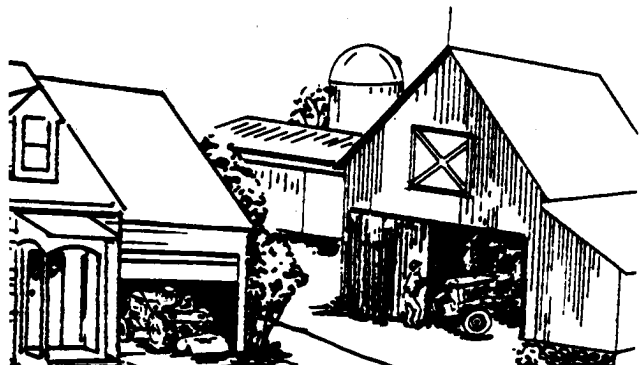

DX,CRPRV,D -19-03MAR93

TS143 -UN-23AUG88

WHEN PARKING OUTDOORS

Make machines hard to move:

- Park in a well-lighted, fenced area.
- Lower all equipment to the ground.
- Remove ignition key. Remove battery when unit is in storage.
- Lock cab doors, windows, and vandal-proof devices.
- Set wheels in widest position making loading more difficult.

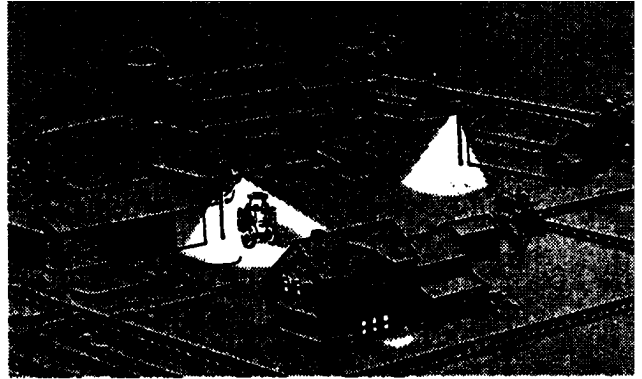

DX,CRPRV,E -19-03MAR93

TS155
-UN-23AUG88

REDUCE VANDALISM

1. Install vandal-proof devices.
2. Participate in a neighborhood watch program. Take written notes of suspicious vehicles or persons and report your findings to law enforcement agency.
3. Regularly verify that identification plates have not been removed. If they have, notify law enforcement agency. Order duplicate plates from your dealer.

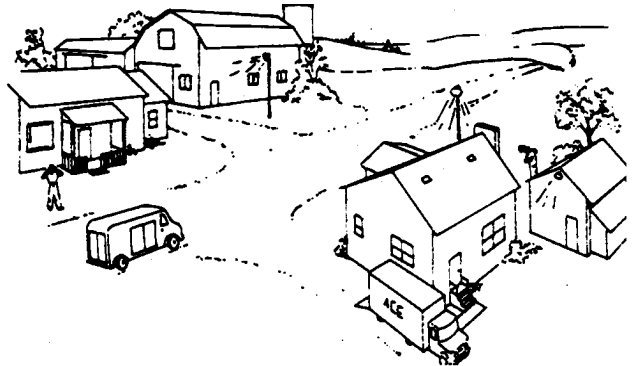

DX,CRPRV,F -19-03MAR93

TS145
-UN-23AUG88

REPORT THEFTS IMMEDIATELY

1. Immediately notify your local law enforcement agency and insurance agent.
2. Provide a complete description of the machine, all of the documented identification numbers and color photographs.
3. Request verification of the identification numbers after they have been entered with any regional or national crime information center. Double check the numbers to be sure they are correct.
4. Notify your John Deere dealer of the theft and request that its loss be posted with full description and identification numbers.



DX,CRPRV,G -19-03MAR93

TS146
-UN-09JAN89

Index

	Page		Page
A		E	
Actuator, Install electric tilt	63	Ejecting bales	13
Adjusting:		Electric bale throwing distance and tilt controls	22
Bale case extensions	21	Electric hand control	14
Bale length	19	End of season	44
Bale length timing	16	Extensions, wheel, install	46
Bale weight	19		
Latch springs	41	G	
Pump drive belts	41	Grease	25
Trip cable	39		
Trip cam	38	H	
Aiming control, hydraulic, using	20	Hand trip lever, using	16
Assembly	46	Hitch release, Install wagon	68
Attachments	22	Hitch release, wagon	23
		Hydraulic Bale Aiming Control	22
B		Hydraulic cylinder kit	23
Bale aiming control, hydraulic	22	Hydraulic cylinder, Install	60, 63
Bale case extensions, adjusting	21	Hydraulic pump, install	58
Bale ejector assembly, install	46	Hydraulic system diagram	43
Bale ejector, checking and adjusting before operation	9	Hydrostatic drive oil	26
Bale ejector, operating the	14		
Bale ejector, preparing the	9	I	
Bale length timing, adjusting	16	Inch torque values	72
Bale length, adjusting	19	Install	
Bale size	13	Wagon hitch release	68
Bale throwing distance and tilt controls, electric	22	Electric tilt actuator	63
Bale weight, adjusting	19	Hydraulic cylinder kit	63
Baling with bale ejector	13	Install:	
Beginning of season	45	Bale ejector assembly	46
Belts, pump drive, adjusting	41	Hydraulic cylinder	60
Breaking in the ejector	9	Hydraulic pump	58
		Wheel extensions	46
C			
Chain, safety	11	L	
Controls, using electric	14	Latch springs, adjusting	41
Cylinder kit, hydraulic	23	Latch, throwing-frame	18
Cylinder, Install hydraulic	60, 63	Lever, hand trip, using	16
		Lubricant	
D		Alternative	27
Distance controls, bale throwing	22	Storage	26
Drive belts, pump, adjusting	41	Synthetic	27
		Lubrication and maintenance	24

Index

	Page		Page
Lubrication and Maintenance		Trip cable, adjusting	39
Each season	30	Trip cam, adjusting	38
Lubrication and maintenance:			
Every 10 hours	28, 29		
Lubrication symbols	24		
		U	
		Using electric hand control	14
M		W	
Maintenance and lubrication	24	Wagon hitch release	23
Metric torque values	73	Wagon hitch release, Install	68
		Wagon recommendations	9
		Weight, adjusting bale	19
		Wheel extensions, install	46
		Wiring diagram	42
O			
Observe lubrication symbols	24		
Oil Hydrostatic drive	26		
Operate safely	2		
Operating the bale ejector	14		
Operating the Side Screens	15		
P			
Perform lubrication and maintenance	24		
Practice safety	38		
Preparing the bale ejector	9		
Pump drive belts, adjusting	41		
Pump, install hydraulic	58		
S			
Safety chain	11		
Safety, practice	38		
Serial number	71		
Service	38		
Side Screens, Operating	15		
Size, bale	13		
Springs, adjusting latch	41		
Storage	44		
Storing lubricants	26		
Synthetic Lubricants	27		
T			
Throwing-frame latch	18		
Tilt actuator, Install electric	63		
Timing, bale length, adjusting	16		
Torque values			
Inch	72		
Metric	73		
Transporting	11		

John Deere Service Literature Available

PARTS CATALOG

The parts catalog lists service parts available for your machine with exploded view illustrations to help you identify the correct parts. It is also useful in assembling and disassembling.



DX,PARTS -19-03MAR93

TS189 -UN-17JAN89

OPERATOR'S MANUAL

The operator's manual provides safety, operating, maintenance, and service information about John Deere machines.

An extra copy of the operator's manual is available. The operator's manual and safety signs on your machine may also be available in other languages. (See your John Deere dealer to order.)



DX,OM -19-03MAR93

TS190 -UN-17JAN89

TECHNICAL AND SERVICE MANUALS

Technical and service manuals are service guides for your machine. Included in the manual are specifications, diagnosis, and adjustments. Also illustrations of assembly and disassembly procedures, hydraulic oil flows, and wiring diagrams.

Component technical manuals are required for some products. These supplemental manuals cover specific components.



DX,TM -19-03MAR93

TS224 -UN-17JAN89

FMO AND FOS MANUALS

These are basic manuals covering most types and makes of machinery. FMO manuals tell you how to OPERATE agricultural machinery; FOS manuals tell you how to SERVICE machine systems. Each manual starts with basic theory and is fully illustrated with colorful diagrams and photographs. Both the "whys" and "hows" of adjustments and repairs are covered in this reference library.



DX,FMOFOS -19-03MAR93

TS195 -UN-02DEC88

John Deere Service Keeps You On The Job

JOHN DEERE IS AT YOUR SERVICE WHEN YOU NEED IT

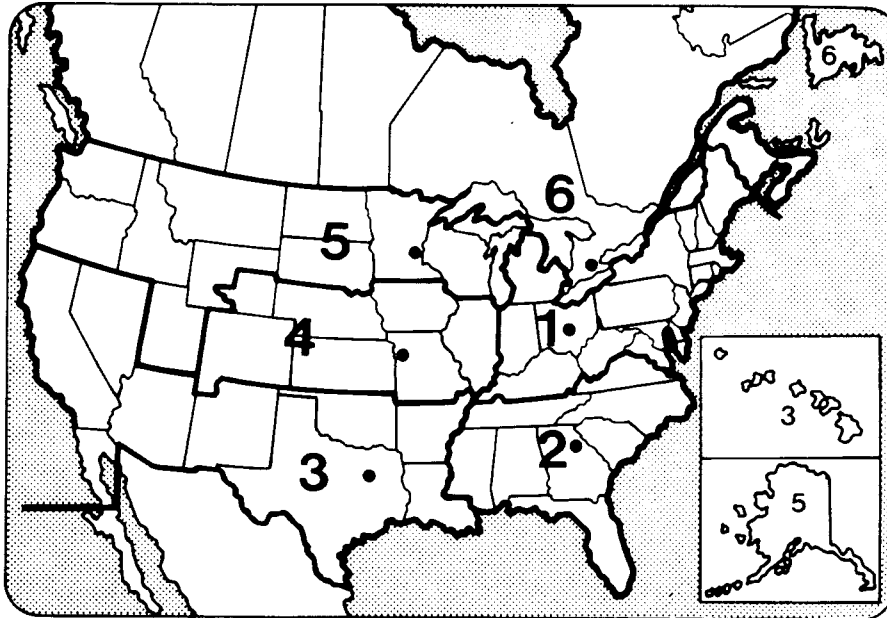

1. JOHN DEERE COMPANY
701 Georgesville Road
Columbus, OH 43228-2499
614-275-1500 (Fax. 614-275-1450)
612-887-6200 (Fax. 612-887-6385)

3. JOHN DEERE COMPANY
P.O. Box 540598
Dallas, TX 75354-0598
214-385-1701 (Fax. 214-663-2390)

5. JOHN DEERE COMPANY
2001 West 94th Street
Bloomington, MN 55431-3211

2. JOHN DEERE COMPANY
2001 Deere Dr.
Conyers, GA 30208
404-922-7040 (Fax. 404-388-2138)

4. JOHN DEERE COMPANY
3210 East 85th Street
Southeast Station
Kansas City, MO 64132-2586
816-361-4000 (Fax. 816-995-9381)

6. JOHN DEERE LIMITED
South Service Road at Hunter
Grimsby, Ontario, Canada L3M 4H5
905-945-9281 (Fax. 905-945-0341)

CUSTOMER SATISFACTION is important to John Deere. We take pride in providing superior service. We'll be around when you need us:

- We maintain a large and varied parts inventory to help minimize downtime.
- Precision tools and testing equipment enable technicians to locate and correct troubles.
- We hold regular training schools for service technicians so they know your equipment and how to maintain it.
- Our goal is to provide prompt, efficient service through competent dealerships.

COMPLAINT-RESOLUTION PROCEDURE

Your dealer is the best and fastest source to solving any problems you may experience with your product.

1. Be prepared with the following information:
 - Machine model and product identification number
 - Date of purchase
 - Nature of problem
2. Discuss problem with dealer service manager.
3. If unable to resolve, see the dealership manager. Explain the problem and request assistance.
4. If you have a persistent problem your dealership is unable to satisfy, ask your dealer to contact the John Deere territory aftermarket manager for resolution.
5. If a problem is not resolved to your satisfaction, contact the appropriate John Deere sales branch for your area and ask to speak with the division aftermarket manager. (See map.)

