



# **ROUND BALER F440E/F450E**

## **OPERATOR'S MANUAL**

**ROUND BALER F440E/F450E**  
**5FBD606 (Nov-16) English**

John Deere GmbH & Co. KG  
Portfolio Extension Region 2

DEERE & COMPANY  
Moline, Illinois  
All rights reserve





## Introduction

READ THIS MANUAL carefully, to learn proper operation of the machine and to correctly perform maintenance works. In this way, you can avoid injury or equipment damage.

This manual and safety signs on the machine are also available in other languages (contact your **John Deere** dealer to order).

THIS MANUAL SHOULD BE CONSIDERED a permanent part of the machine and must accompany it at the time of sale.

MEASUREMENTS in this manual are given in both the metric system and in the Imperial system.

Use only correct spare parts and fastening devices.

Fastening devices in metric and inch sizes may require the use of special wrenches (metric or inch size).

THE LEFT AND RIGHT SIDES are to be intended as looking in the direction of advancement of the equipment.

THE PRODUCT IDENTIFICATION NUMBERS (P.I.N.) are to be taken note of in the Technical Specifications or Identification Numbers section. Accurately record all numbers to facilitate recovery of the machine in case of theft. These numbers must be communicated to the dealer when ordering spare parts. Identification codes must be kept in a safe place away from the system.

BEFORE DELIVERING THE MACHINE, the dealer should have performed a pre-delivery inspection. After the first 100 hours of operation, schedule an after-sale inspection with the dealer to ensure the best performance.

THIS BALER HAS BEEN DESIGNED SOLELY for normal agricultural or similar purposes ("INTENDED USE"). Any other use shall be considered as an improper use. The manufacturer disclaims any liability for damage or injury resulting from improper use. These consequences will be borne solely by the user. Scrupulous compliance with operating modes and regular maintenance and repairs specified by the manufacturer are considered essential elements within the context of intended use.

THIS BALER MUST BE USED, serviced and repaired only by personnel aware of its particular specifications and relevant safety standards (accident prevention). Always act in compliance with accident prevention regulations, general safety and occupational health standards and road traffic regulations.

Any unauthorised modifications made to this baler free the manufacturer from any liability for damage or injury.

TO ANYONE WHO HAS PURCHASED A USED MACHINE, please contact an area **John Deere** dealer to communicate the serial number of the vehicle. This will allow **John Deere** to inform the new owner regarding product improvements or other information.

Original manual.

All information, illustrations and technical specifications contained in this manual are based on the latest information available at the time of publication. Subject to change without notice

---

## Pre-delivery inspection

Predelivery service is the service John Deere recommends that a dealer perform on a machine before delivering it to a customer. This includes assembly, adjustment and inspection. The service assures that the machine will be delivered to the customer in good condition and that the customer will be fully satisfied with its performance right from the start.

### Before machine delivery, the following inspections, adjustments and interventions were performed:

- 1. All grease fittings lubricated.
- 2. Gearbox oil level checked and topped up (as necessary).
- 3. Tire inflation checked and adjusted.
- 4. All wheel bolts and nuts tightened to specific torque.
- 5. Grease removed from the mesh cutter.
- 6. Monitor battery cable properly connected.
- 7. Testing cycle performed.
- 8. Hatch opened and closed freely.
- 9. Pre-cutting device properly operating.
- 10. Monitor properly operating.
- 11. Switches and sensors properly adjusted.
- 12. Hydraulic valve properly adjusted.
- 13. Absence of leaks from hydraulic hose or respective connections verified.
- 14. Proper main chain tension.
- 15. Proper chain tension and lubrication verified.
- 16. Paint and stickers smooth and clean.
  
- 17. Delivery and explain the operator's manual to the customer.
- 18. Delivery of other documentation (CE – road approval where required).
- 19. The operator is aware of the safety precautions to be followed with the machine.
- 20. The operator is aware of need to get the hydraulic valve adjusted by the dealer in case the tractor has different oil flow than 25 l/min.

**Date:**

**Signature of the dealer:**

---

## TABLE OF CONTENTS

Machine views .....	00-1	Preparing the baler .....	20-1
General safety standards .....	05-1	Bale chute .....	20-1
Recognise safety information .....	05-1	Binding .....	20-2
Know signal terminology .....	05-1	TWINE binder .....	20-2
Follow safety instructions .....	05-2	Twine selection .....	20-2
Safe baler use .....	05-3	Joining with a sheet bend knot (plastic twine) .....	20-2
Protecting persons and animals .....	05-4	Joining with a modified square knot (Sisal twine) .....	20-2
Preparing for emergencies .....	05-4	Loading the single twine binder .....	20-3
Wear safety clothing .....	05-4	Loading the dual twine binder .....	20-4
Getting used to working safely .....	05-5	NET binder .....	20-6
Safe machine maintenance .....	05-6	Selecting the net roll .....	20-6
Keep away from rotating parts of the transmission .....	05-6	Taking care of the net roll .....	20-6
Net binder safety catch .....	05-7	Taking care of the net binding device .....	20-6
Managing the binder blades .....	05-7	Loading the net binder .....	20-7
Dangers associated with high pressure fluids .....	05-8	Tyre inflation .....	20-11
Complying with maximum transport speed .....	05-8	Pick-up wheel inflation .....	20-11
Ballast, wheel distance and tyre inflation check .....	05-8	Connection and disconnection .....	25-1
Use lights and safety devices .....	05-9	CONNECTION .....	25-1
Electrical lines .....	05-9	Steering head adjustment .....	25-2
Keep heat sources away from pressurised fluid tubes .....	05-9	Adjusting the tow-bar / towing eye .....	25-3
In case of fire .....	05-10	Wheel hub adjustment .....	25-4
Removal of paint before welding or heating .....	05-10	Tractor connection .....	25-6
Hatch safety catch .....	05-11	Safety chain .....	25-7
Maximum hydraulic operating pressure .....	05-11	Connecting the telescopic shaft to the PTO shaft of the tractor ...	25-8
Covers .....	05-12	Cardan shaft decal .....	25-9
Cardan shaft safety .....	05-13	Connecting the tractor hydraulic system .....	25-10
Pick-up transmission safety .....	05-13	Connecting flexible hydraulic hoses for lifting the collector and hatch .....	25-10
Feeding transmission safety .....	05-13	Connecting the seven-contact outlet for towing .....	25-11
Cardan support .....	05-13	Installing and connecting baler wiring to the monitor .....	25-12
Cardan safety chain .....	05-13	DISCONNECTION .....	25-13
Rod holder support and guide .....	05-13	Disconnecting the telescopic shaft / cardan shaft from the PTO shaft of the tractor .....	25-13
Parking wedges .....	05-14	Repositioning the telescopic / cardan shaft .....	25-13
Support the machine properly .....	05-15	Arranging the flexible hydraulic hoses .....	25-13
Avoid applying high pressure on safety labels .....	05-15	Disconnecting from the tractor .....	25-13
Avoid applying high pressure on cylinders .....	05-15	Transport and parking .....	30-1
Dispose of waste properly / ecology and pollution .....	05-16	Towing the baler on public roads .....	30-1
Safety stickers .....	10-1	Round baler use .....	35-1
Safety symbols / pictograms .....	10-1	Safety start .....	<b>35-Errore. Il segnalibro non è definito.</b>
Operator's manual .....	10-1	Running in .....	35-2
Repairs and maintenance .....	10-1	Preparing the product .....	35-2
Lifted hatch .....	10-2	Swath size .....	35-2
Hatch safety lock .....	10-2	Preparing hay for baling .....	35-2
Opening the hatch .....	10-2	Preparing silage for pressing .....	35-2
Moving parts .....	10-3	Preparing straw for baling .....	35-2
Hydraulic system .....	10-4	Adjusting pick-up wheels .....	35-3
Danger of crushing / cutting .....	10-4	Rake .....	35-3
Safety catch (with net binder only) .....	10-4	Bale density .....	35-4
Steering head frame fastening screws .....	10-5	Product feeding .....	35-4
Connecting plate fastening screws .....	10-5	Swath width equal to collector width .....	35-4
Preparing the tractor .....	15-1	Tight swath .....	35-4
Adjusting the tow-bar .....	15-2	Medium sized swaths .....	35-4
High attachment adjustment .....	15-2	Short, dry, smooth product bales .....	35-5
Selecting the tractor PTO regime .....	15-3	Use of the baler on corn stalks .....	35-5
Control unit support (dovetail) installation .....	15-4	Use of the baler with silage and wet products .....	35-5
Electrical circuit and baler power requirements .....	15-4	Manual declogging / removal of product .....	35-6

## Table of contents

Twine binder adjustment .....	35-7	Transport roller chain tensioning (left side).....	55-5
Net binder adjustment .....	35-8	Transport roller tensioning (right side) .....	55-5
Hatch safety catch.....	35-10	Tensioning the packer chain (left side).....	55-5
Forming a bale .....	35-11	Tensioning the pick-up chain (left side).....	55-6
Binding and unloading bales .....	35-12	Tensioning the pick-up chain (right side).....	55-6
Bale ejector (optional kit).....	35-13	Catenary .....	55-7
Resetting the mechanical bale counter .....	35-13	Release.....	55-7
Use of the "Electric Control" control device.....	37-1	Replacing the pick-up safety screw .....	55-8
"Electric Control" control system .....	37-1	Replacing the safety screws on the feeding transmission .....	55-8
On/Off button.....	37-1	Replacing collecting teeth.....	55-9
Twine binder button.....	37-1	Adjusting pick-up cams.....	55-10
Net binder button.....	37-1	Sharpening the blade.....	55-11
Indicator light.....	37-1	Electric and electronic components .....	55-12
TWINE binder operation.....	37-2	After the first 30 working hours .....	55-12
NET binder operation .....	37-2	Daily checks.....	55-12
Attachments .....	40-1	Special maintenance .....	55-12
Accessories .....	40-1	Machine garaging / storage .....	60-1
Kits .....	40-1	Preparing the baler for garaging / Cleaning.....	60-2
Lubrication and maintenance .....	45-1	Preparing the baler for the start of a season / Before returning to the field .....	60-3
Safe machine lubrication and maintenance .....	45-1	Technical specifications.....	65-1
Compliance with maintenance intervals .....	45-1	Baler dimensions .....	65-1
Performing lubrication and maintenance.....	45-1	Weight.....	65-1
Grease.....	45-2	Pick-up.....	65-2
High-viscosity oil for gearboxes .....	45-2	Transport unit.....	65-2
Oil for Multiluber chains.....	45-3	Binding.....	65-2
Alternative and synthetic lubricants.....	45-3	Bale specifications .....	65-2
Lubrication storage.....	45-3	Cardan shafts .....	65-3
Alternative and synthetic lubricants.....	45-3	Tyres.....	65-3
Lubrication mixing .....	45-3	Tyre specifications .....	65-3
Automatic chain oiling regulation .....	45-4	"Electric Control" control system specifications .....	65-4
Tank .....	45-4	Noise level .....	65-4
Filter (annually).....	45-4	CE Declaration of conformity.....	65-5
Gear box oil level (30 working days).....	45-5	Serial / identification numbers.....	70-1
Draining and refilling the gear box (annually).....	45-6	Serial number plate description .....	70-1
Draining oil .....	45-6	Baler identification number .....	70-1
Topping up oil (annually).....	45-7	Security against burglary .....	70-2
Flexible hydraulic hoses (annually) .....	45-7		
Lubrication operations .....	45-8		
Greasing points (30 working hours) .....	45-8		
Greasing cams (10 working hours) .....	45-8		
Greasing the transmission shaft (30 working hours).....	45-9		
Manual chain oiling (10 working hours).....	45-9		
Wheels and tyres (30 working days) .....	45-10		
Removing / assembling wheels.....	45-11		
Troubleshooting.....	50-1		
Feeding .....	50-1		
Bale formation .....	50-2		
Binding .....	50-2		
Cardan shaft.....	50-3		
Hydraulic system .....	50-3		
Maintenance.....	55-1		
Original spare parts .....	55-1		
Welding (annually).....	55-2		
Replacing hydraulic components .....	55-2		
Tightening bolts (annually) .....	55-2		
Baler steering head .....	55-2		
Tightening torque table .....	55-3		
Tensioning chains (30 working days).....	55-4		
Adjusting automatic tensioners .....	55-4		
Adjusting manual tensioners .....	55-4		

**MACHINE VIEWS**



Baler model: **F450E**

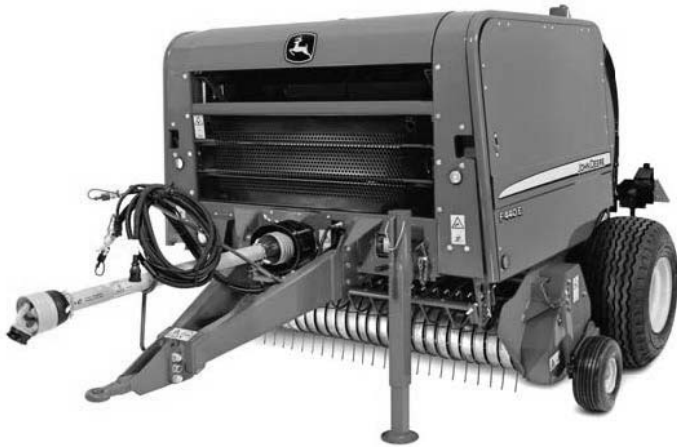

Baler model: **F440E**



## GENERAL SAFETY STANDARDS

In addition to the provisions contained in this operator's manual, observe all general safety regulations and accident prevention regulations in your country.

This machine has been designed and constructed for maximum safety at work. The user is required to maintain these safety conditions.

Therefore, read this manual very carefully; in particular, safety instructions, paying close attention to those operations which may prove particularly dangerous. Read before working!

**John Deere disclaims any and all liability for failure to comply with safety and prevention instructions contained in this manual.**

**In addition, the company disclaims any liability for damage caused by improper use of the baler or by modifications carried out without authorisation.**

### Recognise safety information

This is a safety warning symbol.

When present on the machine or in the manual, it alerts a potential for personal injury.

Comply with precautions and follow all recommended safety operations.



### Know signal terminology

Warning words are used with safety symbols: DANGER, WARNING or CAUTION.

The word DANGER indicates riskier situations.

DANGER or WARNING symbols are located near specific hazards.

General precautions are identified by CAUTION safety signs.

The word CAUTION in this manual also calls attention to safety messages.



## Follow safety instructions

### Before operating the machine:

- Learn how to properly use the machine and controls. Do not allow use by untrained persons.
- Periodically check the conditions of the machine as a whole, including all safety and protection devices.
- Carefully read all safety messages contained in the manual and on safety signs applied to the machine.

Keep safety signs in good condition. Replace any missing or damaged safety signs.

Make sure that new equipment components and spare parts for repairs are complete with current safety signs. Spare part safety signs are available from your **John Deere** dealer. (Spare parts and components sourced from other suppliers may contain additional safety information not shown in this operator's manual).

- All safety guards must be mounted and secured according to manufacturer instructions and must never be tampered with. Keep your machine in proper operating condition.

All safety guards must be mounted and secured according to manufacturer instructions. Any changes made without authorisation can compromise machine operation and/or safety to the user.

If you do not understand any part of this manual and need assistance, contact your **John Deere** dealer.

### **IMPORTANT:**

- **Do not use the commands, pipes or other protruding parts of the machine as handholds.**
- **Assemble, operate and disconnect the cardan shaft always according to information and safety standards supplied for shaft use, contained in the manual provided by the shaft manufacturer and delivered with the shaft itself.**
- **The transport of persons or animals on the machine or on the tractor is strictly prohibited.**



### **CAUTION!**

**Use of the baler by any person who has not read and understood the information contained in this manual is strictly prohibited.**

### Safe baler use

#### **CAUTION!**

- Never leave the machine unattended during operations.
- Never leave the tractor unattended with the engine running.
- Do not allow the use of the machine by children or unqualified persons, or anyone not in good health or not in possession of a valid driver's license.

Before use, always check road conditions and general safety conditions of the machine.

#### **CAUTION!**

Always perform the following operations before entering the working area of the machine:

- Disconnect the power take-off (PTO).
- Stop the tractor engine.
- Remove the main switch key.
- Relieve hydraulic pressure.
- Engage the locking unit.
- Engage the parking brake.
- Wait for all moving parts to come to a complete stop.
- Switch off the "Electric Control" system.

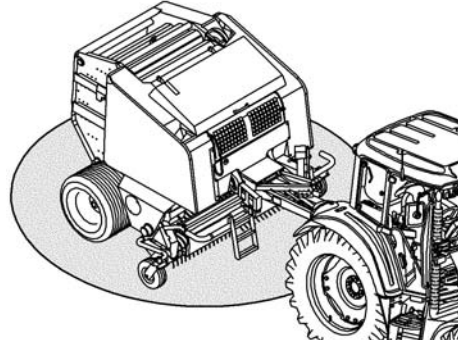

During machine operation, the presence of persons near moving parts is strictly prohibited, as is touching moving parts or standing between them. Keep your face, hands and feet away from moving parts. Keep at a safe distance.

#### **CAUTION!**

To avoid serious injury or death caused by remaining caught in the machine, **DO NOT** attempt to manually feed product, twine or net into the baler with hands or feet or with the aid of any other objects and do not unclog the feeding zone **WHILE THE BALER IS IN MOTION**.

The machine feeds product faster than it can discharge it.

#### In the event of product flooding in the feeding zone:

- Stop the tractor, remove the keys from the dashboard and wait for all moving parts of the machine to come to a complete stop.
- Switch off the "Electric Control" system.

### Protecting persons and animals

Do not allow the passage or stopping of any person close to a machine in operation.  
During operation, keep people, livestock and pets away from the working area of the machine.

### Preparing for emergencies

Be prepared in the event of a fire.  
Keep an extinguisher and first aid kit on hand.  
Keep emergency service numbers near the telephone:  
doctors, ambulance service, hospital, and fire.



### Wear safety clothing

Wear suitable clothing during operations.  
Wear close fitting clothing and safety equipment appropriate to the type of work being performed. Never wear loose clothing that could become hooked in the mechanisms and the moving parts of the machine.

Long hair must be pulled back.



During maintenance and repair operations, use of the following protections are required:

- safety gloves
- safety shoes
- visor and/or safety goggles

Safe operation requires the full attention of the operator. Do not wear headphones for the radio or music while operating the machine.

Prolonged exposure to noise can cause impairment or loss of hearing. To guard against or uncomfortable loud noises, wear a suitable hearing protective device such as headphones or earplugs.

In the event of work or maintenance operations which generate dust or substances harmful to your breathing, use suitable PPE.

**Getting used to working safely**

Learn maintenance procedures before starting work.  
Keep the area clean and dry.  
Keep hands, feet and clothing far away from moving parts.



**Never lubricate, service, or adjust the machine in motion.**

**Disengage all motion transmission components and operate controls to relieve pressure.**

- **Lower equipment to the ground.**
- **Stop the engine.**
- **Remove the ignition key.**
- **Let the machine cool down.**

Securely support any machine components that must be raised for maintenance. Keep all parts in good condition and properly installed.

Immediately repair any damage.

Replace any worn or broken parts.

Remove any build-up of grease, oil or debris.

**On self-propelled vehicles, before making adjustments on electrical systems or welding on the machine, disconnect the ground wire from the battery.**

**On towed equipment, before servicing electrical system components or welding on the machine, disconnect electrical wiring from the tractor.**

**Safe machine maintenance**

Tie back long hair. When operating the machine or moving parts, do not wear necktie, scarves, loose clothing, or necklaces. Severe injury can be caused if these items were to get caught in the machine.

Remove rings and other jewellery to prevent electrical shorts and entanglement in moving parts.



**Keep away from rotating parts of the transmission**

Entanglement in rotating shafts can cause serious injury or death.

Make sure that tractor and drive shaft guards are always mounted and that rotating guards can rotate freely.

Wear close fitting clothing. Stop the engine and make sure the PTO transmission shaft has come to a complete stop before performing adjustments and connections, and before cleaning PTO controlled equipment.



**Range of action of the machine**

The range of action of the machine is to be considered a hazardous area: before operating the machine, make sure that there are no people or animals within the borders of the work area. If any are present, stop the machine and remove them.

**The user of the baler is liable towards third parties for damage caused by the machine within this range.**

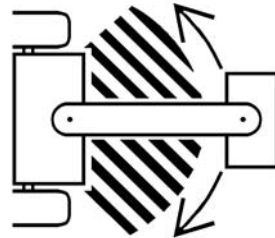

**Bale expulsion/discharge danger**

Do not stand behind the machine. The hatch may be open and the bale may eject.



Discharge bales on flat ground or in a suitable position, in the case of sloping ground.



### Net binder safety catch

**⚠ CAUTION!**

Before intervening on net binders or in the binder area, position a safety catch to avoid amputation or crushing of hands.

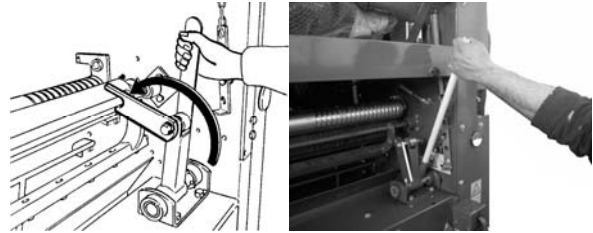

The lever used to operate (lock or unlock) the safety catch is on the left side of the machine (inside the side). Put the lever in the slot (located on the left side of the machine inside the side) when not in use.

**⚠ CAUTION!**

**NEVER WORK ON A NET BINDER WITH THE LEVER STUCK INTO THE TUBE OF THE SAFETY CATCH.**

After engaging the safety catch (locked or unlocked) always place the lever into the slot on the left side of the machine (in the side) when not in use.

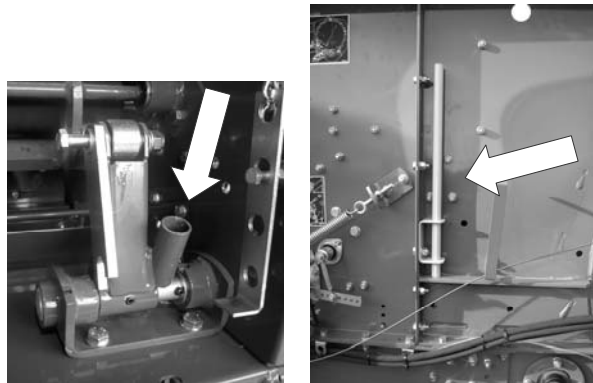

### Managing the binder blades

Prevent injuries.

Wear safety gloves when managing binder blades.



### Dangers associated with high pressure fluids

Splashes of liquid under pressure can penetrate the skin and cause serious injury.

To avoid personal injury, relieve pressure before disconnecting hydraulic hoses or other lines. Tighten all fittings before restoring pressure.

Use a piece of cardboard to identify leaks.

Protect hands and body from high pressure liquids. In case of injury, contact a doctor immediately.

Any fluid injected into the skin must be surgically removed within a few hours or gangrene may result. Medical personnel unfamiliar with this type of injury should consult appropriate medical documentation.



Hydraulic couplings must always be perfectly clean. Always cover them with the plastic protective caps supplied after each use to avoid getting them dirty or damaging them.

Check and, if necessary, replace any damaged pipes or fittings. All flexible hoses should be replaced after 5 years from the date stamped on the hose.

### Complying with maximum transport speed

**IMPORTANT:** Never circulate on public and/or private roads with a bale in the baler chamber.

Always empty the chamber before leaving the field and make sure that the hatch is closed and locked.

Before towing the machine, withdraw the locking unit in the transport position.

**IMPORTANT:** Maximum transport speed is determined by the local highway code and the capabilities of this equipment.

When driving on public roads, always comply with road rules.

When towing this equipment at transport speed, do not exceed its gross weight (GVW).

Some tractors are able to operate at higher speeds with respect to the maximum transport speed of this equipment. Regardless of the maximum speed that the tractor used to tow this equipment can reach, do not exceed the maximum equipment transport speed.

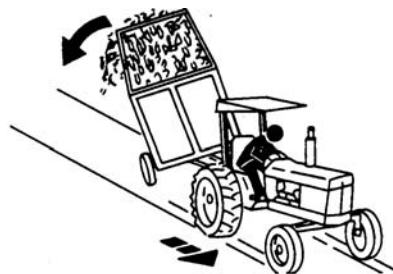

**IMPORTANT:** Exceeding the speed of transport of the equipment can result in:

- loss of control of the tractor/equipment unit
- reduction or total absence of braking
- damage to equipment tyres
- damage to structure or components
- of equipment

When towing loads on surfaces in poor condition, around corners or on slopes, proceed with caution and further reduce speed.

### Ballast, wheel distance and tyre inflation check

Make sure that the ballast, the distance of wheels and tyre inflation are suitable to the type of tractor and that they ensure proper machine stability in all conditions, especially for use on hilly terrain and in adverse conditions. Consult the tractor operator's manual.

### Use lights and safety devices

Prevent collisions with other road users, slow tractors with mounted or trailed equipment and self-propelled machinery. Frequently check vehicles arriving from behind, especially before turning corners, and use turn signals.

Use the headlights, turn signals and warning indicators both at night and during the day. Comply with road rules regarding lighting vehicles and various signalling. Maintain lights and different signalling means visible and in good condition.

Replace or repair lighting and damaged or lost signalling devices.

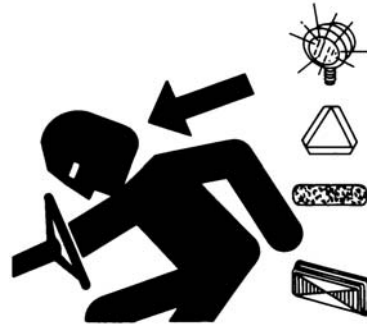

### Electrical lines

Be very careful to keep a minimum safe distance when operating near electric power lines. The machine is mainly constructed of metal; therefore, if it should come in contact with electrical lines or there is a discharge between the line and the machine, the operator risks fatal harm.

In the case of operation in the vicinity of electric power lines, contact the authority responsible for power distribution.

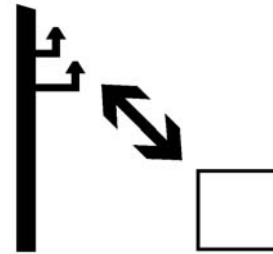

### Keep heat sources away from pressurised fluid tubes

The heating of tubes containing fluid under pressure can cause a spray of flammable vapour, causing severe burns to the person working and to people around.

During welding or brazing operations or when using open flames, do not heat the areas near the pressurised fluid tubes or other flammable materials. The heat in the area just beyond the tip of the flame can cause the accidental explosion of pressurised tubes.



**In case of fire****CAUTION! RISK OF FIRE**

Regularly remove the accumulated product to reduce the risk of fire and to prevent material from twisting around mechanical machine components.

If the bale catches fire:

1. Immediately eject bale.
2. Move the tractor and baler as far away as possible from flammable material, making sure the wind does not blow the fire in the direction of the machine.
3. Lift the hatch and insert the locking device.

**To extinguish the fire, use a pressurised water fire extinguisher or an alternative water supply.**

**Removal of paint before welding or heating**

Avoid potentially toxic fumes and dust.

The heating of paint during welding operations or when using a flame can generate hazardous fumes.

Before heating:

- Remove paint over an area of at least 100mm in diameter around the point that will be affected by heating. If you cannot remove the paint before heating or welding, wear an approved respirator.
- Do not breathe in dust when you sand or grind paint. Wear an approved respirator.
- If using a solvent or paint stripper, remove residues with soap and water before starting welding operations. Keep solvent or paint stripper containers away from other flammable material.  
Allow fumes to disperse for at least 15 minutes before welding or heating.

Do not use chlorinated solvents in welding areas.

Perform all work in a well-aerated area where toxic fumes and dust can be vented.

Properly dispose of paint and solvent.



### Hatch safety catch

Before working on the baler or around it with the hatch lifted, lock both jack rods (one on the right side and one on the left side) with suitable catches, inserting the safety pin.

Remember to remove both safety catches from the hatch before closing it to prevent causing serious damage to the machine structure!

To avoid accidents, keep at a safe distance from the hatch while it is being raised or lowered.

Before activating the hatch, make sure that no one is nearby.

Remove foreign objects from the machine.

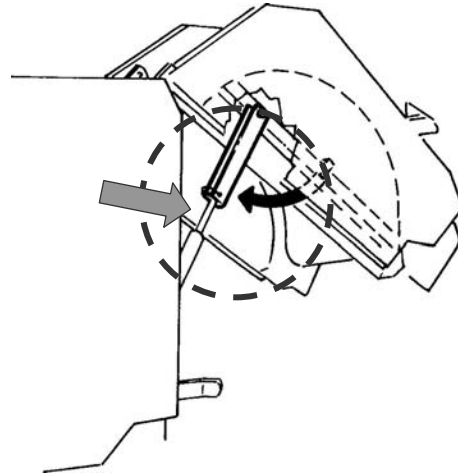

**IMPORTANT:** Make sure that the hatch is closed, visually checking the pressure gauge. It must be between the yellow and the green sector and, however, must indicate a pressure of between 80÷130bar (8,000÷13,000kPa)

If the working pressure exceeds the set value closing the tailgate and with a low PTO speed, you have to adjust it with the hydraulic valve.

**Please contact your Dealer to perform this operation.**

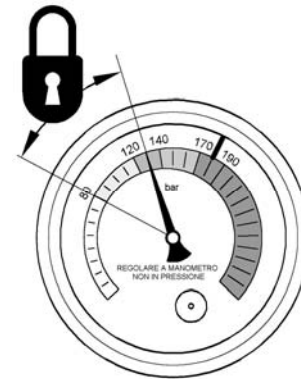

### Maximum hydraulic operating pressure

The baler has been designed for a maximum hydraulic operating pressure of 19,000 kPa (190 bar).

Prevent connecting the baler to a tractor that supplies a maximum hydraulic operating pressure higher than 190bar (19,000 kPa).

### The tractor must provide a oil flowrate of 25 lt/min

If the tractor provides a higher flowrate and during the working phase the set value for the pressure is exceeded, you have to correctly adjust the hydraulic valve.

**Please contact your Dealer to do this operation.**

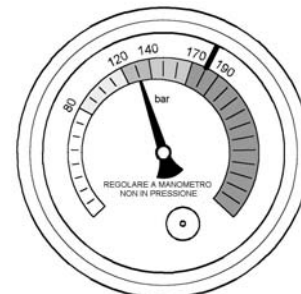

**max pressure = 190bar (19,000 kPa)**

## Covers

The machine is equipped with covers. These protect the operator from moving mechanical parts and shelter these same mechanical parts from any accidental intrusion of debris.

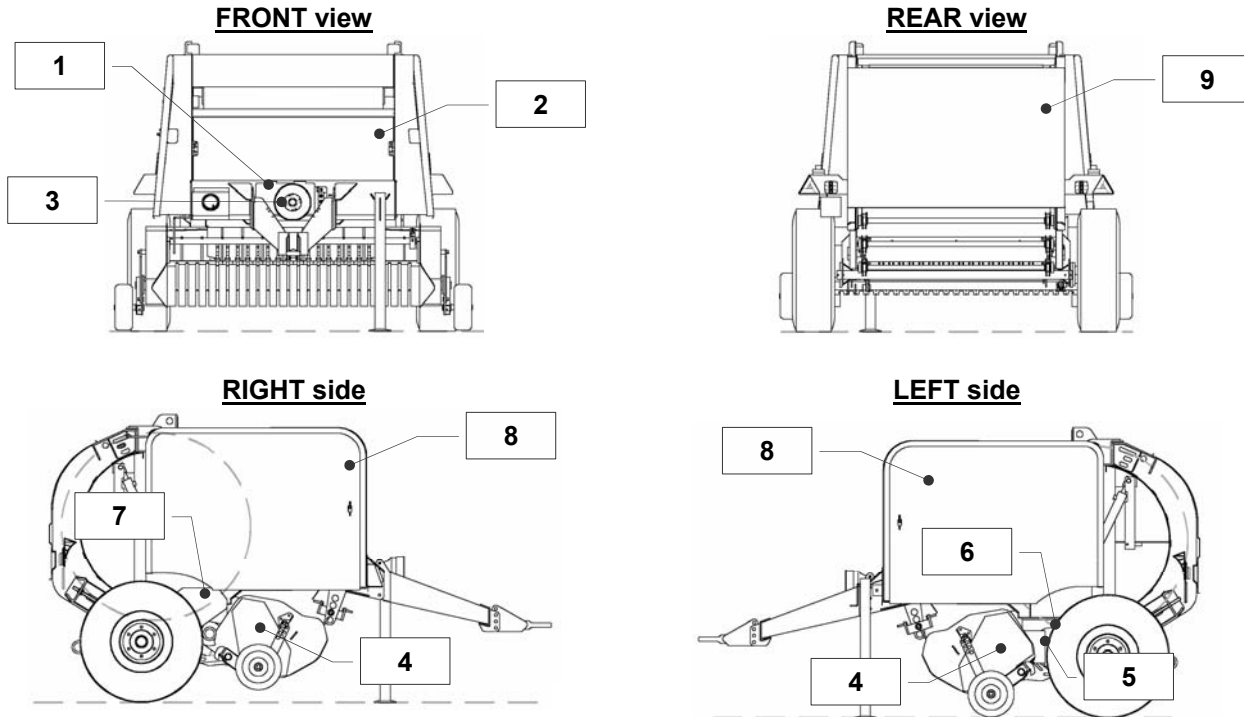

- 1) Junction box protective cover
- 2) Front cover
- 3) Cardan shaft/gearbox protective cap
- 4) Pick-up cover (right and left)
- 5) Collection unit cover (left side)
- 6) Large roller cover
- 7) Transmission/feeding cover
- 8) Side covers (right and left)
- 9) Rear hatch covers

A safety lock has been provided on the side covers to ensure perfect closing of the machine cover, thus avoiding any accidental opening of the cover itself during working operations or transport.

To open, use a 13mm wrench.

### CAUTION!

**Before removing any covers or protective shields:**

- **Stop the machine.**
- **Switch off the tractor and remove keys from the tractor dashboard.**

**Cardan shaft safety**

Each cardan shaft is equipped with a safety system to protect mechanical parts against high starting torque and maximum torque:

- FV = with torque limiter clutch
- SB = with shear bolt



**Pick-up transmission safety**

The pick-up transmission is equipped with a shear bolt safety device against overloading and foreign bodies.

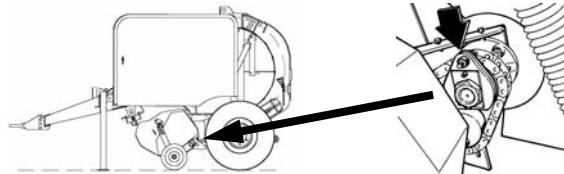

**Feeding transmission safety**

The feeding device motion transmission is equipped with a safety with two shear bolts against overloading and foreign bodies.

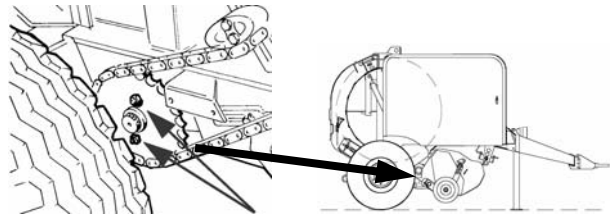

**Cardan support**

Supports the shaft when it is not connected to the tractor to prevent damage to it.

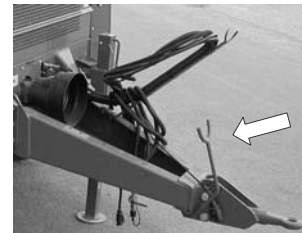

**Cardan safety chain**

Prevents cardan shaft guard rotation during work. Fasten to the steering head.

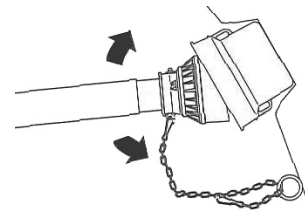

**Rod holder support and guide**

Hydraulic hose, electrical cable and wiring support.

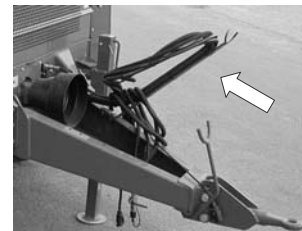

**Parking wedges**

Positioned under tyres to block the machine and prevent any accidental movement while parked and any time the machine needs to be blocked for repair, maintenance or cleaning operations.

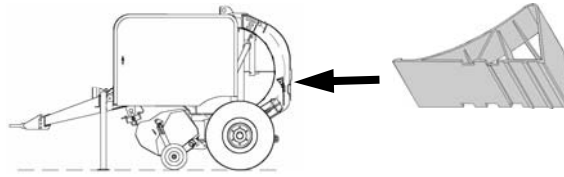

### Support the machine properly

Before performing any work on the machine, always lower the component or equipment to the ground. Provide adequate support if the servicing to be performed requires machine or equipment lifting. Hydraulically supported devices, if kept in the raised position, may settle or drop because of leakage. Do not use cinder blocks, bricks or other material that could give out under a continuous load to support the machine. Never work under a machine supported only by a jack. Always follow the instructions in this manual. When using equipment or accessories together with the machine, always follow the safety precautions listed in the accessory or equipment operator's manual.



### Avoid applying high pressure on safety labels

**Avoid applying high pressure on safety labels**  
Pressurised water can damage or remove safety labels. Avoid applying high pressure directly on safety labels. Immediately re-apply missing safety labels or replace damaged ones. Spare safety labels are available from your **John Deere** dealer.

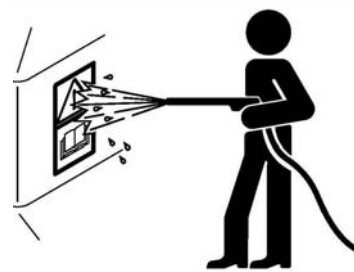

### Avoid applying high pressure on cylinders

Pressurised water can damage cylinders. Avoid applying high pressure directly on cylinders



**Dispose of waste properly / ecology and pollution**

**IMPORTANT: Respect the laws in your country concerning the use and disposal of products used for machine operations, maintenance and cleaning.**

Improper disposal of waste can threaten the environment and ecological system. The components used for **John Deere** equipment which are potentially hazardous waste include: oil, fuel, coolant, brake fluid, filters, and batteries.



**IMPORTANT: Use airtight containers for drained fluids. Do not use food or beverage containers that may mislead and cause accidental drinking.**

**Do not drain onto the ground, into sewage systems or in watercourses.**

Air conditioner coolants, which are dispersed outdoors, can alter the atmosphere. It is advisable to recover and recycle used air conditioning coolants at qualified centres, especially where established by regulations.

Dispose of any remaining machine packaging in suitable sorted waste containers.

**IMPORTANT: Consult the relevant authorities for disposal or recycling centres.**

## SAFETY STICKERS

### Safety symbols / pictograms

Adhesive signs containing important messages for personal safety are affixed on the machine. Their purpose is to call the operator's attention to safety and health guidelines, as well as to possibly dangerous work and maintenance situations.

These safety signs are black and red pictograms on a yellow background.

They should always be kept clean and legible and must be replaced immediately whenever they have been removed and/or damaged.

When putting on new ones or painting areas where they were present, safety signs must be replaced as they were found originally.

For this purpose, each adhesive contains a Spare Parts Service order code number. When requesting adhesive safety signs from our Spare Parts Service department, specify relative codes.

**IMPORTANT:** To receive the full range of safety signs stickers for the baler, request the following code from our Spare Parts Service department: "5FB7Z00077 = CE safety decal"

All safety signs decals on the baler are shown and described on the following pages.

Read and understand the meaning of the signs and disseminate this information to your staff and anyone else who may approach the machine during work or maintenance.

Read and understand the meaning of the signs and disseminate this information to your staff and anyone else who may approach the machine during work or maintenance.

### Operator's manual

code 5FB7500185

Before operating the machine, at the beginning of each season and before working on the machine, read and keep in mind the use and maintenance instructions in the operator's manual.

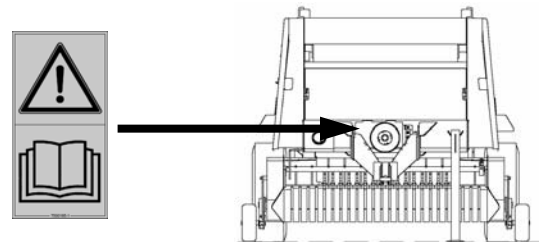

### Repairs and maintenance

code 5FB7500186

CAUTION! Before doing maintenance or repairs on the machine, switch off the tractor engine, remove the keys from the dashboard and read the operator's manual.

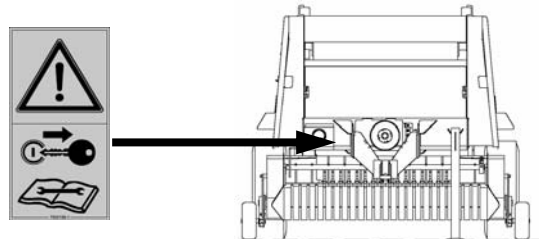

**Lifted hatch**

code 5FB7500198

CAUTION! Do not move or stand under the hatch when it is lifted unless the appropriate safety catches have been inserted, to avoid crushing.

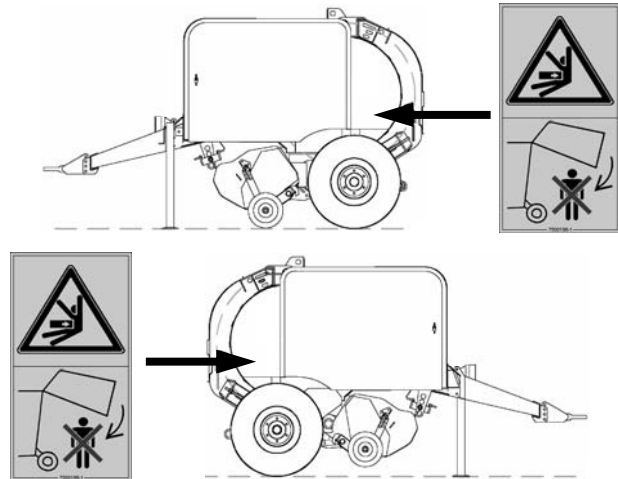
**Hatch safety lock**

code 5FB7500194

CAUTION! Before entering into the bale forming chamber for servicing or other, block hydraulic jacks with the appropriate safety catches to prevent crushing.

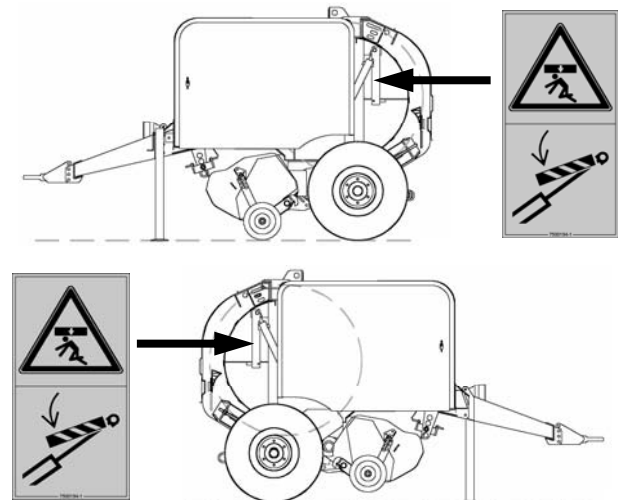
**Opening the hatch**

code 5FB7500197

CAUTION! Do not stand behind the machine to avoid being crushed by sudden manoeuvres.

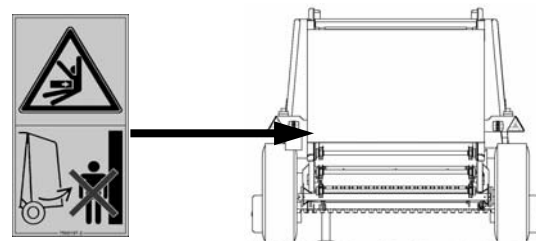

**Feeding**

code 5FB7500207

CAUTION! Never hand feed or remove material in front of the pick-up collector as long as parts are moving. This could cause entrapment of the upper limbs or more severe injury to persons.

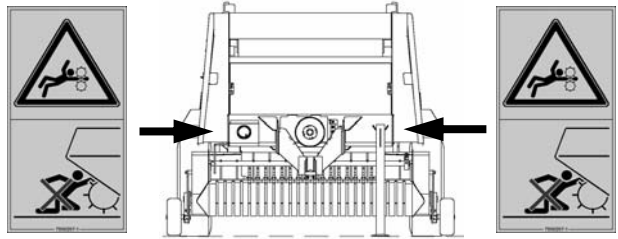

**Moving parts**

code 5FB7500203

CAUTION! Before performing any work, wait for all parts of the machine to come to a complete stop and prevent any unwanted movement using appropriate equipment.

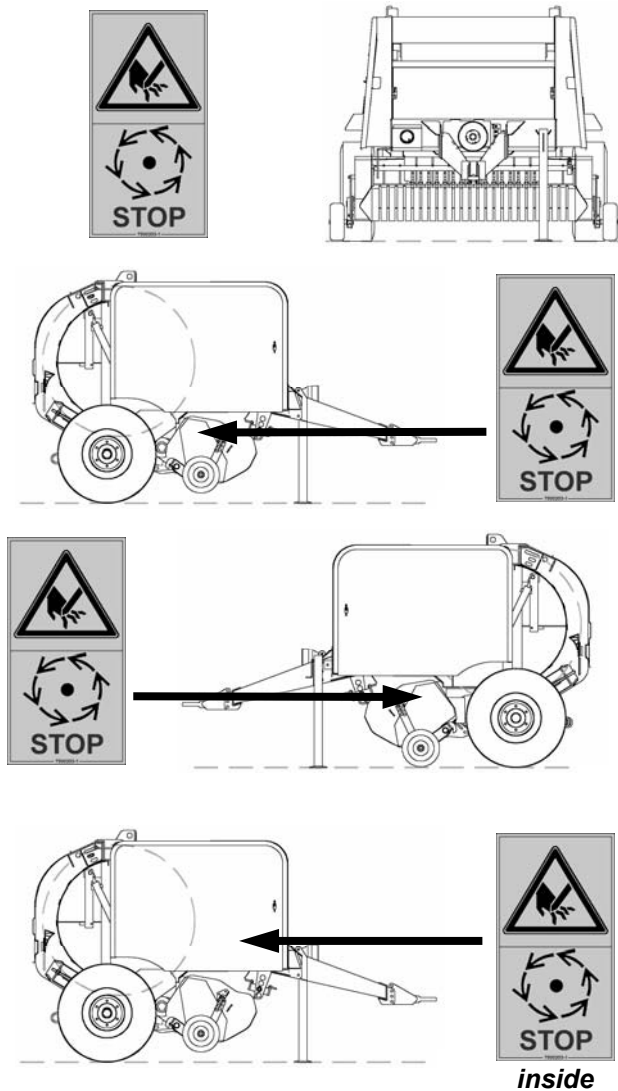

**PTO rpm**

code 5FB7500187

CAUTION! Machine suitable for tractors with PTO a 540rpm/1' and direction of rotation.

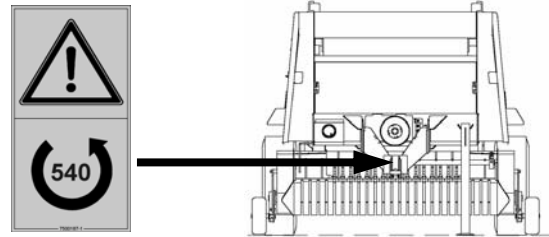
**Hydraulic system**

code 5FB7500208

CAUTION! Consult the operator's manual before working on the hydraulic system.

Pressurised oil can cause serious infections.

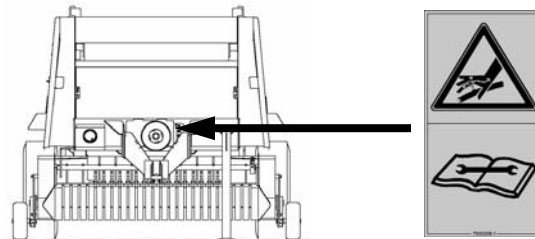
**Danger of crushing / cutting**

code 5FB7500221

CAUTION! Do not get too close to the machine, as this could cause crushing or cutting of the lower limbs, due to the weight or lowering of the machine.

Keep a safe distance.

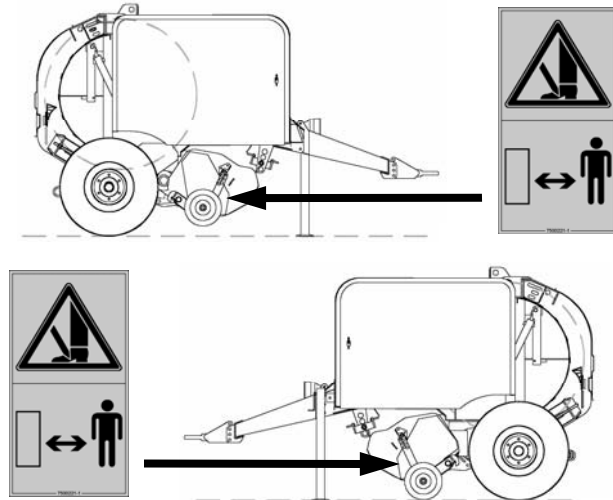
**Safety catch (with net binder only)**

code 5FB7500320

CAUTION! If you need to remove guards for servicing, place a safety catch in the mechanism to avoid crushing or amputation of the upper limbs, due to their own sudden and dynamic charge.

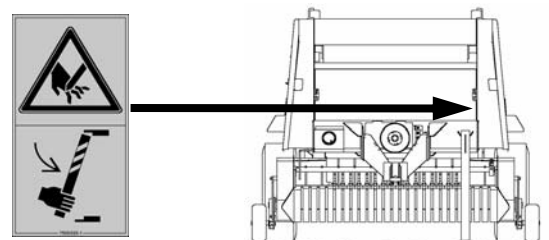

**Steering head frame fastening screws**

code 5FB75P0207

Retighten steering head frame fastening screws at specified intervals.

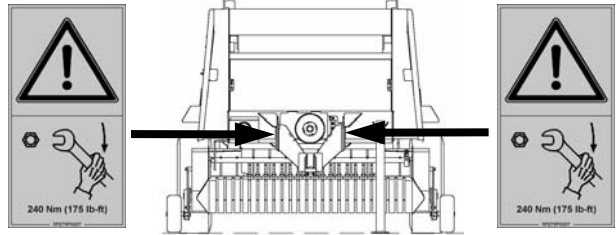

**Connecting plate fastening screws**

code 5FB75P0208

Retighten connecting plate fastening screws at specified intervals.

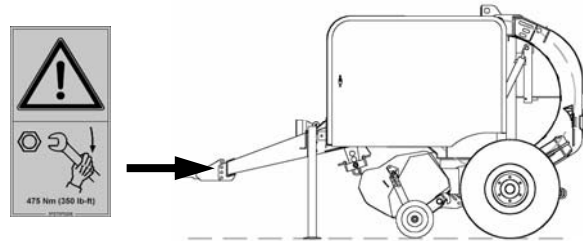



## PREPARING THE TRACTOR



### **CAUTION!**

**Take extra care as tractor connection operations can be dangerous.**

Use a tractor with the appropriate characteristics for towing the machine in use.

Make sure that there are no objects resting on the machine and that there are no persons and/or animals in the immediate vicinity.

The machine steering head is equipped with a pivoting towing eye.

**IMPORTANT!** Before adjusting the steering head, make sure that:

- **tyres are properly inflated**
- **the hatch is closed**

### Adjusting the tow-bar

**IMPORTANT: Adjust the tow-bar before attaching the baler. Reassemble all guards.**

Machines exit from the company with a "STANDARD" tractor connection.

If necessary, use of a "P" extension for standard attachment of your tractor is permitted within acceptable limits.

Adjust the tow-bar extension to the following specifications:

- between PTO shaft end and tow-bar attachment pin hole axis  
(A) = distance .....300 mm (12 in)
- between PTO shaft and upper tow-bar surface  
(B) = distance .....160÷290 mm (6÷11 in)
- between ground and upper tow-bar surface  
(C) = distance .....450 mm (18 in)

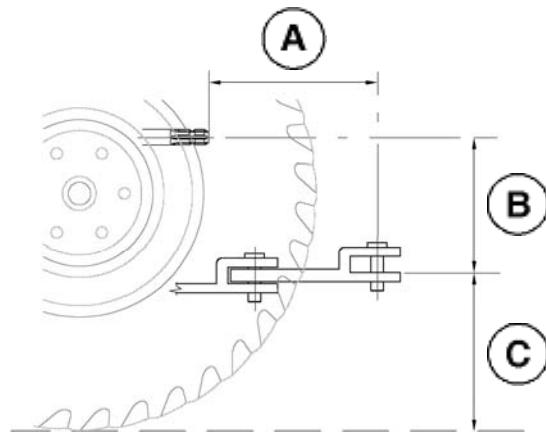

**A = 300 mm (12 in)**  
**B = 160÷290 mm (6÷11 in)**  
**C = 450 mm (18 in)**

### High attachment adjustment

It is possible to hook the baler also to tractors with a "HIGH" towing device, within acceptable limits, as shown in the figure.

To do so, you must adapt the baler steering head to attachment "A" of the tractor.

Adjust the high attachment to the following specifications:

- between PTO shaft end and tow-bar attachment pin hole axis  
(A) = maximum distance.....200 mm (8 in)
- between PTO shaft and upper tow-bar surface  
(B) = maximum distance.....200 mm (8 in)
- between ground and upper tow-bar surface  
(C) = distance .....800÷1050 mm (31÷41 in)

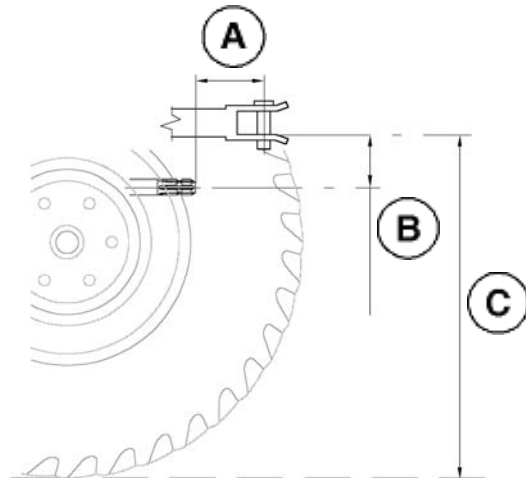

**A max = 200 mm (8 in)**  
**B min. = 200 mm (8 in)**  
**C = 800÷1050 mm (31÷41 in)**

**⚠ CAUTION!**

A high attachment can be used with a measurement of 800-1050mm (31÷41 in).

**⚠ CAUTION!**

**THE USE OF HIGH ATTACHMENTS WHEN DRIVING ON ROADS IS PROHIBITED IN ITALY!**

**When driving on roads, you need to restore the machine steering head with the standard attachment!**

### Selecting the tractor PTO regime

To select the tractor PTO regime, refer to the label on the front of the baler.  
The direction of rotation is that which is indicated by the adhesive safety sign.

#### **Baler with PTO regime at 540 rpm :**

The size of the tractor PTO shaft must be 3.5 cm (13/8 in.).

Consult the tractor operator's manual to install an appropriate PTO shaft and adjust PTO regime.

**IMPORTANT: Stop the PTO during reverse manoeuvres at the end of a swath and when steering at a very narrow angle.**



### Control unit support (dovetail) installation

Fasten the dovetail stably inside the tractor cab.

Position the dovetail in the tractor cab so that the control unit can be easily reached, visible and available to the operator.

The control unit will then be engaged on the dovetail during operations.



### Electrical circuit and baler power requirements

With the tractor switched off, disconnect the ground wire from the battery, then connect the "CT" tractor power cable to the 12V battery terminals, connecting the red wire (+) to the positive pole and the black wire (-) to the negative pole.

Now reconnect the ground wire.

#### **IMPORTANT! Be careful not to invert the poles:**

- RED wire "+" (positive)
- BLACK wire "-" (negative)

**Some power cables may be brown and blue. In these cases, the brown wire is positive (+) and the blue wire is negative (-).**

Fasten the "CT" tractor power cable along the tractor, bringing the COBO connector to the height of the towing eye or near the PTO.

**IMPORTANT: Make sure that the tractor power cable, once connected to the machine cable, does not hit against the PTO and does not interfere with working operations.**

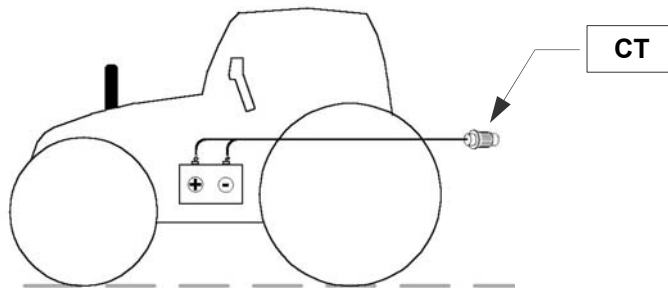

## PREPARING THE BALER

### **Bale chute**

Facilitates moving bales away from the hatch closing range once ejected.

**Not recommended on sloping ground.**

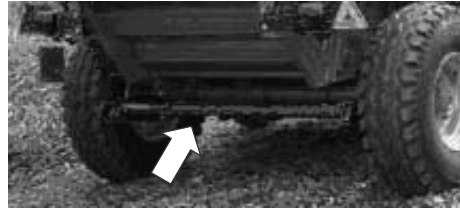

## Binding

The binder can be equipped with three types of binders:

- single TWINE binder
- dual TWINE binder
- NET binder

**The TWINE binder and the NET binder can both be assembled on the machine.**

## TWINE binder

### Twine selection

For best performance, we recommend use of "propylene" twine with a titre from 500 to 750, or else vegetable twine from 200 to 400 m/Kg.

Your baler's twine binder can however also operate with other types of twine.

**It is important to use a good quality twine for proper baling operations.**

For this purpose, twine with good tensile strength and of uniform size should be used. This also prevents its breakage during bale handling or transport.

### Joining with a sheet bend knot (plastic twine)

**IMPORTANT!** The knot must be small enough to pass into guides and the twine holder arm.

Join the twine reels with a sheet bend knot, as shown.

**A = Flow direction of twine**

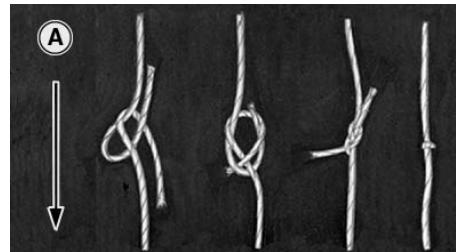

### Joining with a modified square knot (Sisal twine)

**IMPORTANT!** The knot must be small enough to pass into guides and the twine holder arm.

Join the reels with a square knot or a modified square knot, as shown.

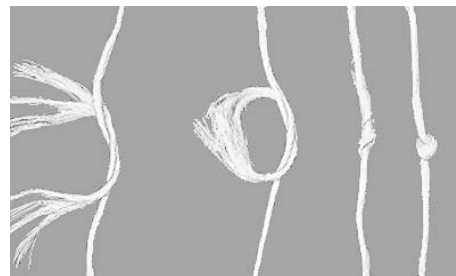

**Loading the single twine binder**

**⚠ CAUTION!**

Loading and threading the twine for binding must be carried out with the engine and control unit switched off.

**⚠ CAUTION!**

Before intervening on twin binders make sure that:

1. the blade arm of the net binder is in the discharge position;
2. the linkage group is off the hook.

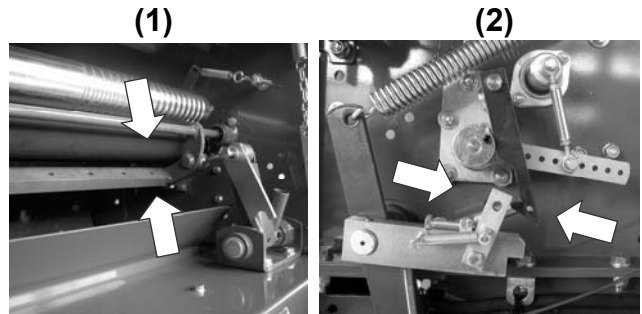

- Lift the cover and arrange the twine reels.
- Verify that the starting position of the twine-guide carriage is as indicated in the picture.
- If not, turn the pulley "P" by hand to a counter-clockwise position until you reach the proper position.

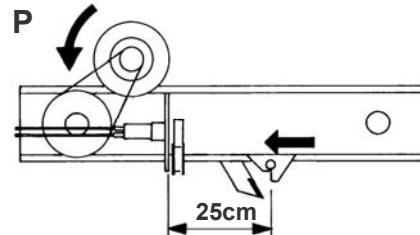

- Cross the twine stop, located on the left side under the reel-holder case, with the twine and wrap it one time and a half around the large pulley. Then insert it between the corrugated drive rollers and let it hang 15-20cm from the last twine-guide ring.
- Connect reels "A, B, C and D" to one another, knotting the inner head of the reel with the outer head of the adjacent one.
- Be careful that knots are properly tightened and that they are small enough not to interfere with the sliding of the twine.

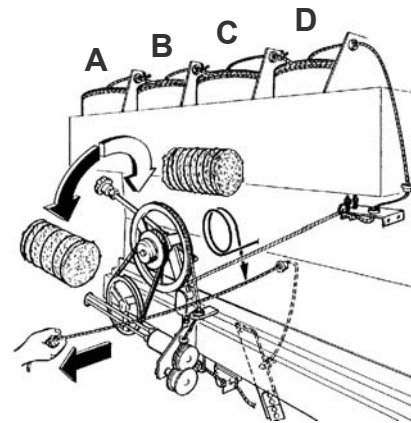

- Cross the twine stop, located on the left side under the reel-holder case, with the twine and wrap it one time and a half around the large pulley. Then insert it between the corrugated drive rollers and let it hang 15-20cm (6+8 in) from the last twine-guide ring.

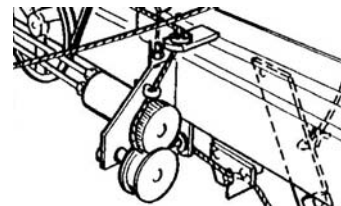

**⚠ CAUTION!**

Do not start work without guards in place.

### Loading the dual twine binder

**⚠ CAUTION!**

Loading and threading the twine for binding must be carried out with the engine and control unit switched off.

**⚠ CAUTION!**

Before intervening on twin binders make sure that:

1. the blade arm of the net binder is in the discharge position;
2. the linkage group is off the hook.

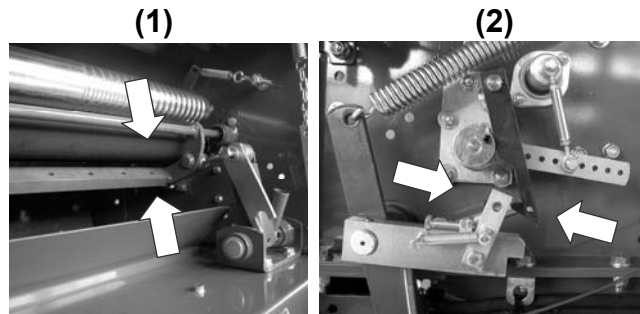

- Lift the cover and arrange the twine reels.
- Verify that the starting position of the twine-guide carriage is as indicated in the picture.
- If not, turn the pulley "P" by hand to a counter-clockwise position until you reach the proper position.

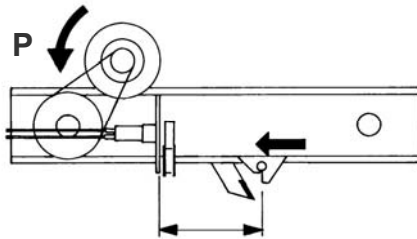

- Connect reels "A and B" to one another and reels "C and D" to one another, knotting the inner head of reel "A" with the external head of reel "B". Do the same for reels "C and D."
- Be careful that knots are properly tightened and that they are small enough not to interfere with the sliding of the twine.

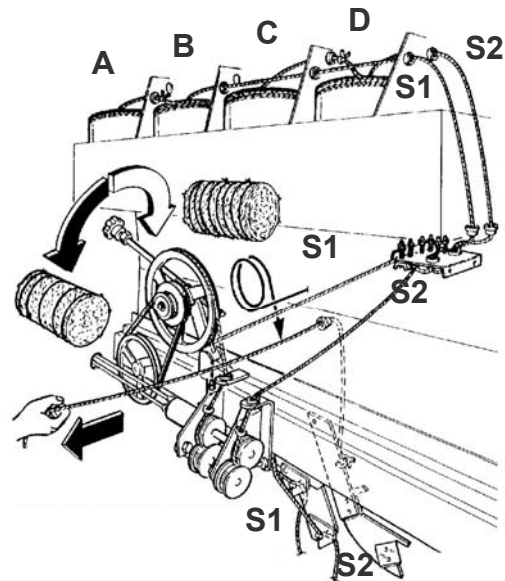

- Cross the twine stop, located on the left side under the reel-holder case.
- Take twine "S1" and wrap it one time and a half around the large pulley. Then insert it between the corrugated drive rollers and let it hang 15-20cm (0,6÷0,8 in) from the last twine-guide ring.
- Then take twine "S2", inset it between the corrugated driver rollers and let it hang 15-20cm (6÷8 in) from the last twine-guide ring.

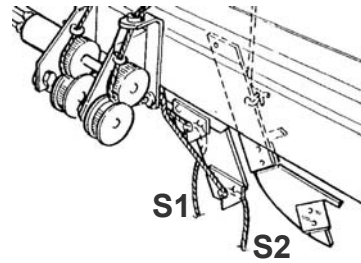

**CAUTION!**

**Do not start work without guards in place.**

Before intervening on net binders or in the binder area, position a safety catch to avoid amputation or crushing of hands.

## NET binder

### Selecting the net roll

The baler is equipped for use with standard type reels.  
For best performance, use 14÷16 g/m net rolls.

**IMPORTANT!** Higher density net rolls can be used.  
In this case, make sure that the net binding device  
is properly adjusted and the blade is sharp.

Net roll diameter must not exceed 30 cm (11.8 in).

A = Area without net

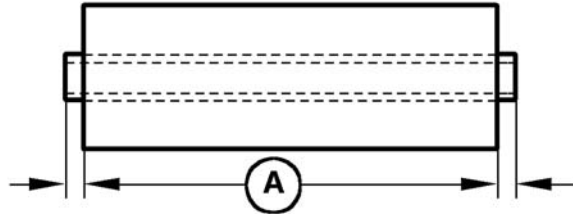

### Taking care of the net roll

**IMPORTANT!** Protect the net roll from humidity and impact. Do not remove the protective cover before use. Protrusions can cause erratic performance and affect bale weather resistance. Do not use tape directly on the net.

Store the roll in a cool, dry place away from direct sunlight.

### Taking care of the net binding device

Before using the press, proceed as follows: thoroughly clean the feeding rollers and check if any part of them is sticky. NEVER use aggressive detergents such as petrol, gasoline, turpentine or similar solvents on the rubber feeding rollers.

**IMPORTANT!** Never spread talcum powder on rubber rollers.

We recommend using:

- water
- soap and water

### Loading the net binder

**⚠ CAUTION!**

Before installing the net binder, disconnect the PTO, engage the parking brake, stop the tractor engine and remove the key. Wait for all moving parts to come to a complete stop.

**⚠ CAUTION!**

Pay attention to the blade of the binder during any operation nearby.

Before intervening on net binders or in the binder area, position a safety catch to avoid amputation or crushing of hands.

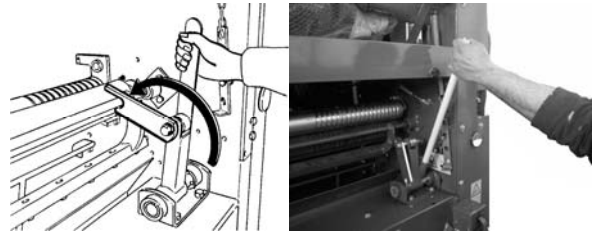

**⚠ CAUTION!**

**NEVER WORK ON A NET BINDER WITH THE LEVER STUCK INTO THE TUBE OF THE SAFETY CATCH.**

After engaging the safety catch (locked or unlocked) always place the lever into the slot on the left side of the machine (in the side) when not in use.

- Open the left side cover and removed the handle.

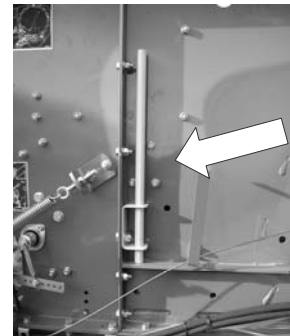

- Insert the handle into the safety catch.

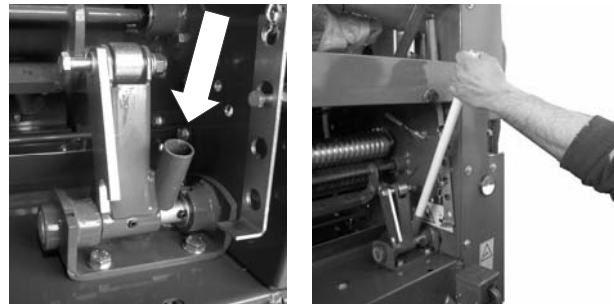

- Engaged the safety catch and lock the arm blade of the net binder.

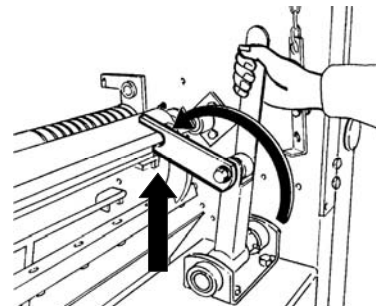

- Remove the handle from the safety catch and place it in the housing the left of the machine.

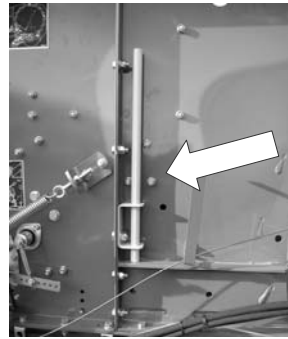

- Completely lift the cover of the roller holder compartment and secure it open with the appropriate safety device.



- Unhook the net stop springs "F" and lift.

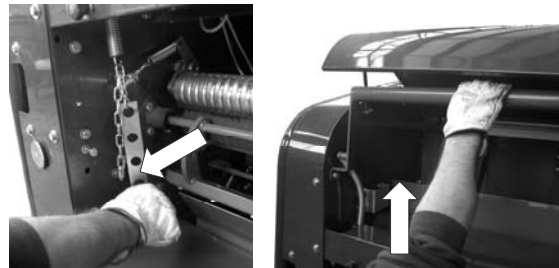

**IMPORTANT!** Before installing the net roll, remove all packaging material from roll (staples, tape, etc.).

- Arrange the net roll inside the appropriate compartment, taking care that the net is pulled from the lower part of the roll.



## PREPARING THE BALER

- Braid twist the end of the net roll and insert it between the rubber roller "RG" and the two smooth rollers "R1" and "R2" (as indicated on the decals applied on the machine).
- Then pass it between blade "C1" and counter-blade "C2" and stretch it along the whole width, letting it hang against the counter-blade "C2" about 20cm (8in).

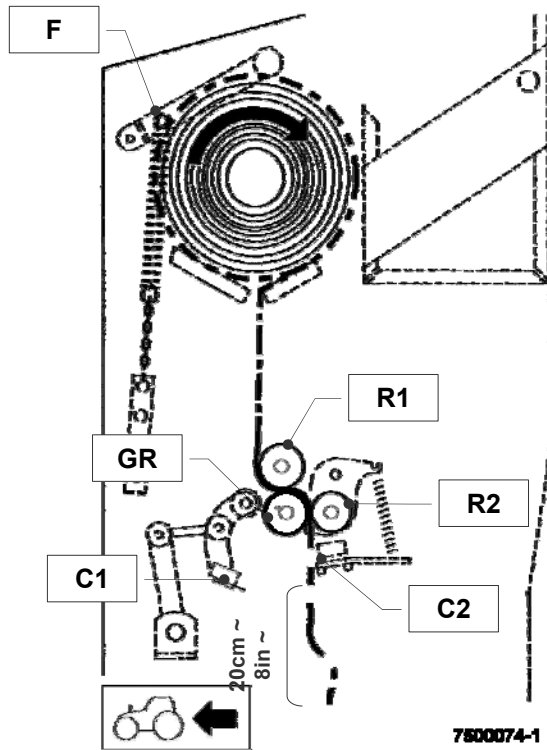

- Rest the net stop on the roll.

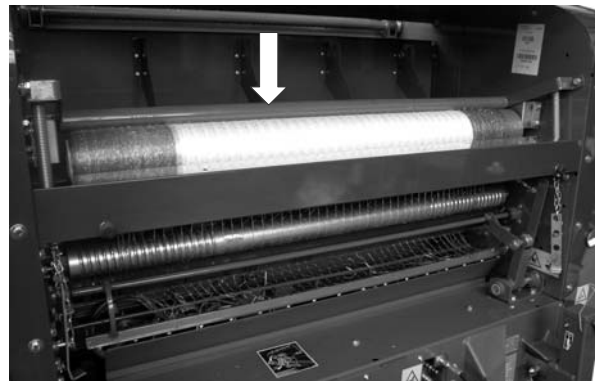

- Hook both springs to the net stop.



- Disconnect the roll holder compartment opening safety device and close.



- Removed the handle on the left side of the machine.
- Insert the handle into the safety catch.

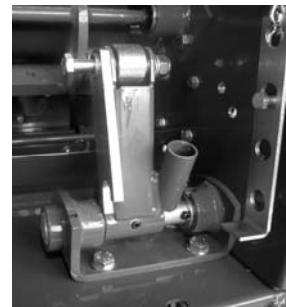

- Deactivate the safety catch and unlock the blade arm of the net binder.



- Remove the handle from the safety catch and place it in the housing the left of the machine.



**⚠ CAUTION!**

Do not start work without guards in place.

**IMPORTANT!:** It is advisable to always remove the net from the feed rollers at the end of the day. This will prevent the roller rubber from forming incrustations of material that the net consists of and prevents starting problems. remove the net from under the rubber roller when the press is used for twine binding.

### Tyre inflation

#### With maximum transport speed of 40km/h (25mph):

- standard tyre: 11.5/80-15. = 3.5bar (350kpa)
- optional tyre: 400/60-15.5 = 3.5bar (350kpa)

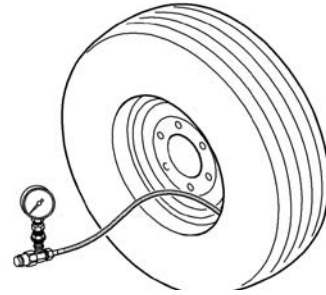

### Pick-up wheel inflation

- = 2.5bar (250kpa)

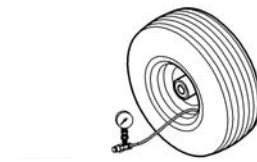



## CONNECTION AND DISCONNECTION

### CONNECTION



#### **CAUTION!**

Take extra care as tractor connection operations can be dangerous.

**Take heed of all basic safety regulations, as contained in chapter "General safety standards".**

Use a tractor with the appropriate characteristics for towing the machine in use.

Make sure that there are no objects resting on the machine and that there are no persons and/or animals in the immediate vicinity.

The machine steering head is equipped with a pivoting towing eye.

The baler steering head can be adapted to the tractor towing device, which can be "STANDARD" or "HIGH".

**In any case, the towing eye must always be parallel to the ground.**

### Steering head adjustment

The machine steering head can be adapted to the tractor only vertically.  
Overturned, it can be used with the "HIGH" towing device of the tractor.

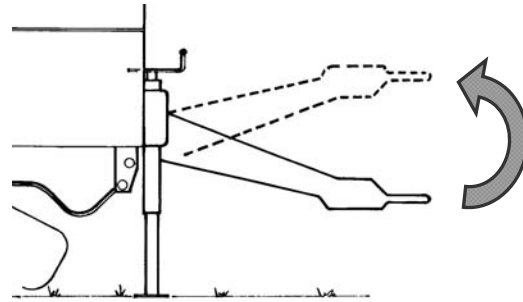

### **CAUTION!**

**Take extra care as steering head adjustment operations can be dangerous.**

To avoid injury from unexpected movement, support the machine firmly on flat, horizontal ground.

Take heed of all basic safety regulations, as contained in chapter "General safety standards".

Screw in six screws (three per side) to fasten the steering head to the machine frame.

Adapt the position of the steering head to the tractor attachment, moving it into the various holes and/or overturning it.



**IMPORTANT!**: insert six screws (three per side) in the holes on the side of the steering head, making sure that they are in the same positions.

**Retighten the six screws (three per side) fastening the frame to the steering head to: 240Nm (175 lb-ft)**

### Adjusting the tow-bar / towing eye

The towing eye can be adapted to the tractor attachment and the cardan shaft position, adjusting it to the height or else overturning it.

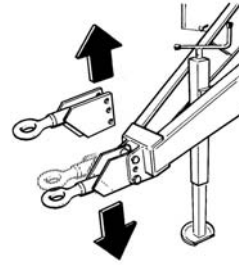

### CAUTION!

**Take extra care as towing bar / towing eye adjustment operations can be dangerous.**

To avoid injury from unexpected movement, support the machine firmly on flat, horizontal ground.

Take heed of all basic safety regulations, as contained in chapter “General safety standards”.

Unscrew the three screws fastening the towing bar / towing eye to the machine steering head.

Adapt the position of the towing bar / towing eye to the tractor attachment, moving it into the various holes and/or overturning it.



**IMPORTANT!** The towing bar / towing eye must always be parallel to the ground.

**Retighten the three screws fastening the towing bar / towing eye to: 475Nm (350 lb-ft)**

### Wheel hub adjustment

When necessary, it is possible to adjust the height of the machine from the ground, turning the wheel hug 180°.

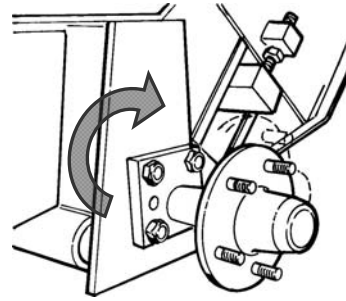

### CAUTION!

**Take extra care as wheel hub adjustment operations can be dangerous.**

To avoid injury from unexpected movement, support the machine firmly on flat, horizontal ground.

Take heed of all basic safety regulations, as contained in chapter “General safety standards”.

**IMPORTANT! To adjust the wheel hub height, use an adequate capacity jack to lift the machine.**

**The machine load on the 1st axis is:**

- F440E = 1780 kg (3924 lb)
- F450E = 2030 kg (4475 lb)

Tyres must also be removed from the machine.

Then position parking wedges under the tyres, alternating them depending on which wheel needs to be removed.



Position the appropriate jack and lift the machine from one side.



Remove the screws fastening the wheel and remove.



Remove the screws fastening the wheel hub.

Adapt the wheel hub position to your needs.

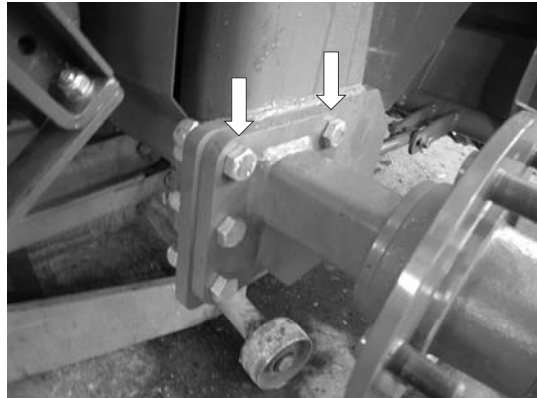

Replace the screws fastening the wheel hub to: 240NM (175 lb-ft)

Reassemble the wheel and replace the six fastening screws to: 230Nm (168 lb-ft)

**IMPORTANT!** Perform the same operations on the opposite side of the machine.  
Then adjust the wheel hub position in the same way on both sides of the machine.

**Tractor connection**

- Hook the baler to the rear hook of the tractor, making sure that the machine is in a stable and horizontal position and that the towing eye is at the same height as the tractor towing device.
- Turn crank "M" of the servo steering head "P" to lower or raise the towing eye to obtain correct alignment with the tractor towing device.
- Insert cotter "S" in the towing eye and secure it with a safety pin. Then lift the servo steering head "P" with the crank "M".

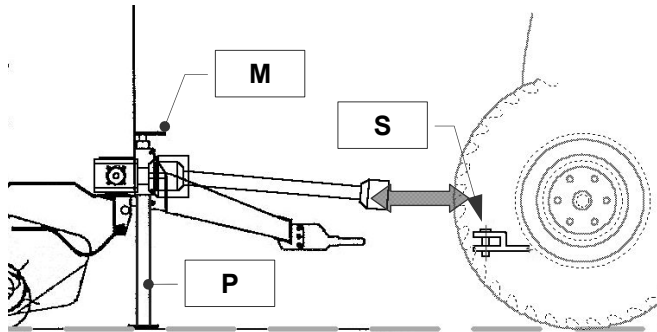

**IMPORTANT!** Make sure that the hatch is closed, visually checking the pressure gauge. It must be between the yellow and the green sector and, however, must indicate a pressure of between 80÷130 bar (8,000÷13,000 kPa).

If the working pressure exceeds the set value closing the tailgate and with a low PTO speed, you have to adjust the value with the hydraulic valve.

**Please contact your Dealer to perform this operation.**

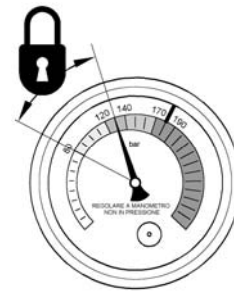

- Then remove any wedges from under the wheels.
- Insert the road transport light system power plug of the baler into the tractor outlet and verify proper functioning of all turn signal, parking and brake lights.
- Make sure that all covers are properly closed and hooked.
- Make sure that the pick-up is in the raised position.

**IMPORTANT!** When driving on public roads, always comply with local road rules.

Remember that you must have the vehicle registration document, and must have applied a duplicate license plate in the space provided on the baler.

**Safety chain (required in France)**

If the machine is equipped with a safety chain, hook and fasten the chain to the tractor. Allow only enough slack for turns.

**The chain must stop the steering head from hitting the ground in the event that the baler accidentally becomes removed from the tractor.**

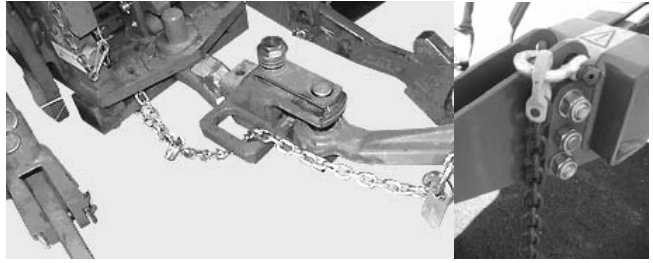

Connecting the telescopic shaft to the PTO shaft of the tractor

**CAUTION!**

The cardan shaft is a transmission component (machine), equipped with a "CE" certificate. Each cardan shaft is equipped with a use and maintenance manual. Always carefully follow information and safety standards supplied for shaft use as contained in the manual.

- Never connect the telescopic shaft when the tractor is moving.
- Never use an iron hammer to connect or disconnect the telescopic shaft from the PTO.

**IMPORTANT!** The ribbed profiles of the telescopic shaft and of the PTO must always be free of any paint, dirt, chaff or burrs.

Be very careful when connecting the shaft. Check that it is properly locked on the PTO.

The cardan shaft attachment, on the tractor side, is highlighted by a decal on the cardan itself.

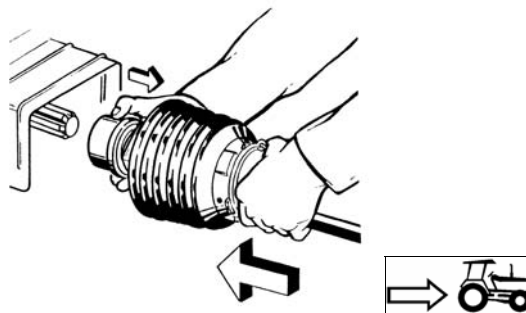

Check that the length never exceeds the minimum distance between the machine and the tractor (risk of jamming).

**Minimum clearance must be 4cm (1,6in).**

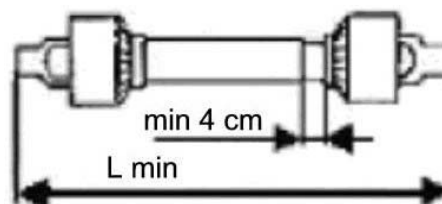

When the cardan shaft is fully extended, the telescopic shafts must overlap by at least 1/3 of their length in all working conditions.

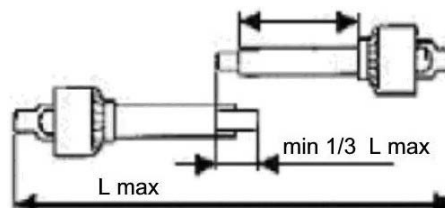

Before starting operations:

- Verify that the safety buttons and screws are properly engaged in the PTO grooves and make sure that the protection turns freely, otherwise it will need to be greased.
- Verify that the appropriate safety chains are present on guards to prevent guards from rotating with the cardan shaft.
- Verify protective caps often and, if they are not completely in good condition, replace them immediately with new protections.

**CAUTION!**

After all maintenance operations performed on the cardan shaft, always reset protective caps on the shaft itself.

During baler operations, replace the cardan shaft support along the steering head side.

John Deere declines any responsible for any consequences of failure to heed warnings.

### Cardan shaft decal

There is a sticker on the cardan shaft which requests the operator complies with safety standards for shaft use.



John Deere **declines any responsible for any consequences of failure to heed warnings.**

**Connecting the tractor hydraulic system**



The maximum working pressure in baler flexible hydraulic hoses is approximately 20,000 kPa (200 bar; 2900 psi). To prevent accidents due to the splashing of fluids under pressure, before connecting or disconnecting hydraulic hoses or other fluid hoses, stop the engine and discharge pressure from the hydraulic system. Tighten all joints before restoring pressure.

**IMPORTANT!:** All hydraulic attachments must be free of dirt, dust or sand. Protect openings with plugs until connected. Debris can damage the hydraulic system.

**NOTE:** The baler is equipped with ISO hydraulic attachments.

If these are not suitable for tractor attachment joints, contact your **John Deere** dealer for proper attachment joints.

- (A) = diameter ..... 23.66 - 23.74 mm (0.931 - 0.934 in.)
- (B) = length ..... 24 mm (0.945 in.)

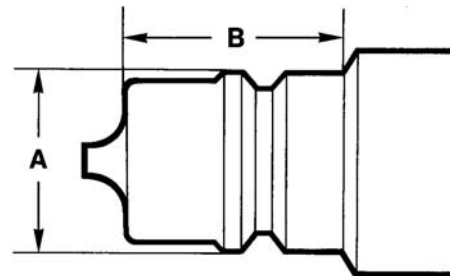

**A = diameter**  
**B = length**

**Connecting flexible hydraulic hoses for lifting the collector and hatch**

Using force, insert the ends of the hoses in the tractor attachments.

To permit the hatch to function, connect the flexible hydraulic hoses (A) of the hatch to a double acting hydraulic distributor. When the tractor hydraulic distributor lever is moved backward, the hatch should open.

Connect the flexible hydraulic hose (B) for lifting the collector to a single acting hydraulic distributor. When the tractor hydraulic distributor lever is moved backward, the collector should raise.

**NOTE:** To connect the flexible hydraulic hose to the connector to the recommended outlet, refer to the tractor Operator's Manual.

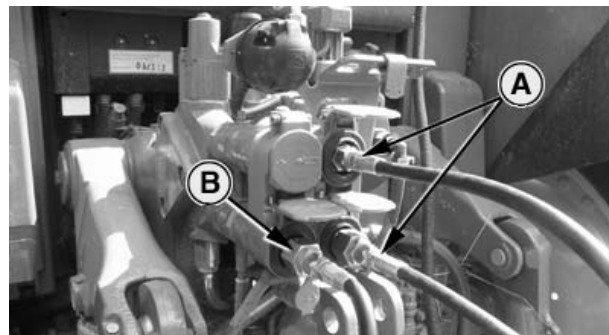

**A = hatch flexible hydraulic hoses**  
**B = collector flexible hydraulic hoses**

**Before lifting the pick-up:**

- Position the stop valve lever to the "OPEN" position and then left it (transport position).
- Then turn the valve lever to the "CLOSED" position to lock it.

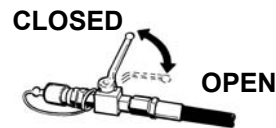

**Connecting the seven-contact outlet for towing**

Connect the road driving light outlet to the seven-contact outlet of the tractor.

The electrical cable of the road driving lights of this machine meets the requirements of ISO 1724.

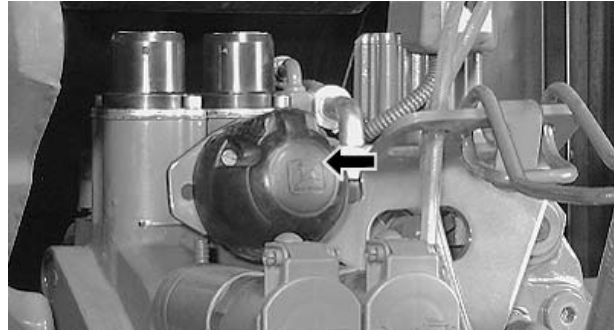

Contact	Function	Reference
1	Left turn signal	L (left)
2	-	54G
3	mass	31
4	Right turn signal	R (right)
5	Rear lights and right marker lights	58R (right)
6	Brake lights	54
7	Rear lights and left marker lights	58L (left)

**Seven-contact tractor outlet**

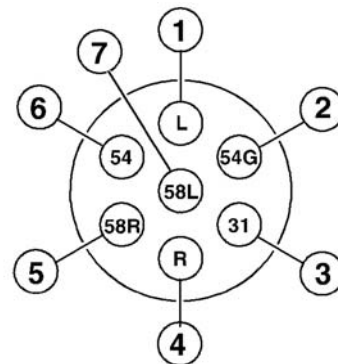

### Installing and connecting baler wiring to the monitor

Check that you have the following material contained in the box supplied with the machine:

- 1) Power cable
- 2) Control terminal
- 3) Dovetail

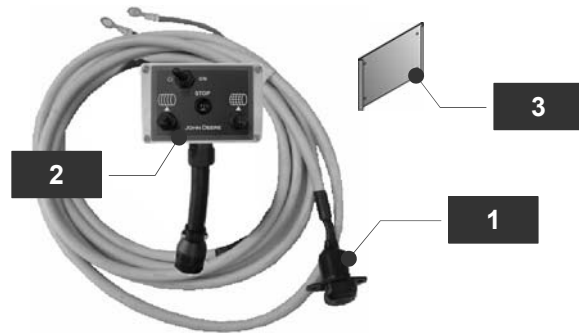

**IMPORTANT:** Make sure that no cables are a hindrance to driving manoeuvres and are not near moving parts.

Make sure that the tractor power cable, once connected to the machine cable, does not hit against the PTO and does not interfere with working operations.

- Connect the signal cable "CS" (equipped with 24-pole rectangular connector) to the control unit plug and tighten the ring nut. Then insert the control unit in the dovetail that was previously installed in the cab.
- Connect the machine power cable "CM" with the tractor power cable "CT." Make sure that the tab of the COBO female connector cover of the machine power cable is engaged in the COBO connector slot of the male COBO connector of the tractor power cable. This will prevent accidental disconnections of the two cables which would result in a system black-out.
- Now verify that the control unit switches on by pressing the relative button. If cables have been properly connected, the system will switch on.

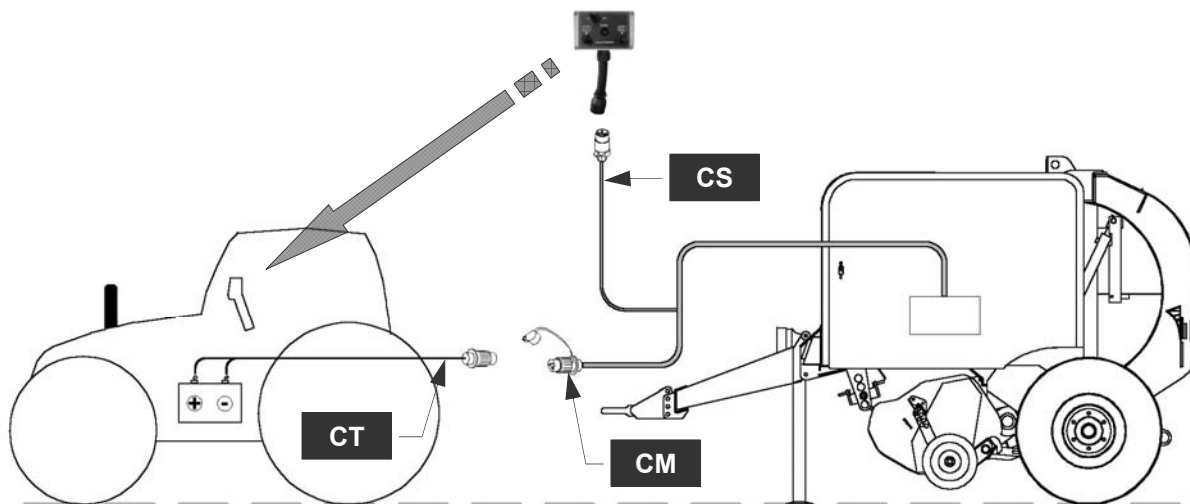

## DISCONNECTION

### Disconnecting the telescopic shaft / cardan shaft from the PTO shaft of the tractor

Disengage the PTO, engage the parking brake, stop the engine and remove the ignition key.

To disconnect the telescopic shaft properly from the PTO shaft, refer to the telescopic shaft operator's manual.

**Replace all protections, if removed.**

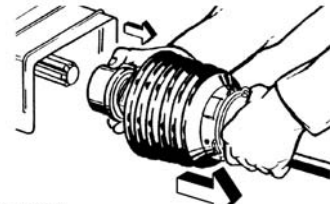

### Repositioning the telescopic / cardan shaft

When adjusting the baler steering head for use with the tractor towing hook, position the support as shown in the figure, so as to rest the telescopic shaft on itself.

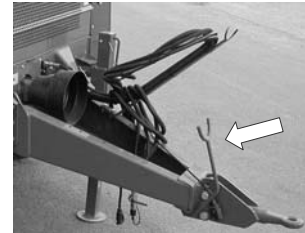

### Arranging the flexible hydraulic hoses



**Splashes of liquid under pressure can penetrate the skin and cause serious injury. To avoid personal injury, relieve pressure before disconnecting hydraulic hoses or other lines.**

Disconnect the flexible hydraulic hoses and install caps on the attachment joints.

Arrange the flexible hydraulic hoses in their relative support to keep them clean, preventing them from coming into contact with the ground.

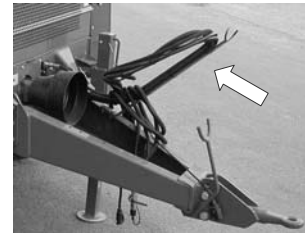

### Disconnecting from the tractor

Before disconnecting the baler from the tractor:

- Move crank "M" to lower the servo steering head to the ground.
- Remove cotter "S" from the towing eye and move the tractor away from the machine.

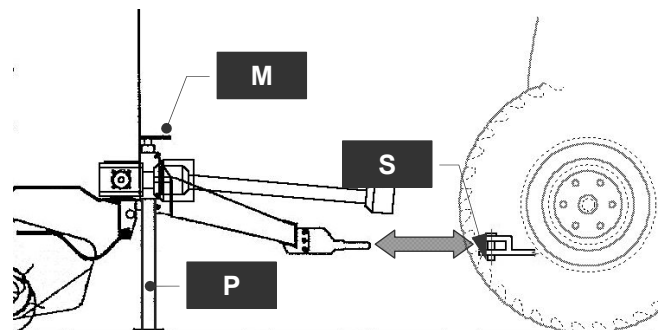



## TRANSPORT AND PARKING

Towing the baler on public roads



When towing this machine on public roads, it is advisable to use signalling lights and turn signals.

- Never use the machine as a means of transport for goods and/or people.
- It is strictly forbidden to drive the baler with bales on board.
- Do not operate the baler during towing.



Use caution when moving the towed baler. Reduce speed if the weight of the baler exceeds the weight of the tractor. The baler must be empty during road transport.

**IMPORTANT:** Avoid tight turns when towing the baler. Considerable damage can be caused if the steering head should hit into tractor tyres.

**IMPORTANT:** The maximum driving speed is determined by local road rules and by tyre size. Consult the "Tyre inflation" paragraph in the "Preparing the baler" section to determine the maximum permitted speed for each tyre and for the baler.

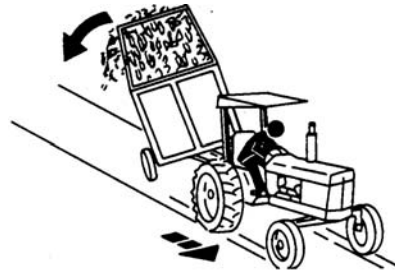



## BALER USE

### Safety start

#### **IMPORTANT:**

**Before you perform these verifications, make sure that no one is in the vicinity**

**All operations should be performed by a single operator who must have read and understood all parts of this manual, particularly the section regarding safety.**

Before starting work, verify that the machine is all in order, that lubricating oils are at the right level and that all parts subject to wear and tear are fully efficient.

**IMPORTANT: Operate for the first time with caution, verifying correct operation of all mechanical and transmission components.**



#### **CAUTION!**

**Unless otherwise specified in this operator's manual, adjustment and preparation for work must only be carried out with:**

- **The tractor switched off and keys removed from the dashboard.**
- **The machine switched off and blocked stably on the ground.**

After making the connections described in the section "Connection and disconnection":

- Switch on the tractor without engaging PTO.
- Verify functioning of the hydraulic system: the opening and closing of the hatch, raising and lowering of the pick-up (remember to bring the stop valve lever to the "OPEN" position to raise the pick-up).
- Verify functioning of electrical connections to the terminal: switch on the "Electric Control" system button.
- Verify functioning of the lighting devices.
- Open the hatch and verify that catenary movement stops.
- Close the hatch, verify that the catenary starts moving again inside the chamber.
- Engage PTO.

Once you have checked the above steps without any abnormality detected, it is possible to begin operations in the field.

## Running in

Consider the first fifty bales as a break-in period (that is, until the paint of the bale chamber becomes smooth).

Before use, heavily lubricate the telescopic components of the connection to the PTO.

**IMPORTANT: If slippage occurs during operation, disengage PTO and re-start it at low speed until the joint engages, then continue working with the PTO at rated speed.**

## Preparing the product

### Swath size

Well-formed, uniform bales are obtained by feeding swath widths that are the same size as the collector, or else half or less of the width of the collector.

Avoid swaths of medium width. When the operator moves to the side on a swath of this size to direct the product at the ends of the collector, the product is continuously fed towards the centre. As a result, more material will be fed toward the centre of the bale than toward the end. The result of this is barrel-shaped bales with a low density at the ends and a high density at the centre.

## Preparing hay for baling

The product to be baled can be prepared in different ways, depending on preference and the equipment available. The best bales are formed with product that is cut, conditioned and raked in appropriate sized swaths. This allows the operator to follow the swath and direct the material into the press in an appropriate manner to produce compact and uniform bales.

The bale forming technique allows a product moisture content up to 18%.

If humidity is too high, the product will deteriorate.

If humidity is too low, an excessive crushing and loss of leaves will occur.

Cut the product as long as possible. In many products, greater length facilitates baling and makes the bales more smooth and weatherproof.

Do not excessively condition the product, especially legumes such as alfalfa and clover.

Excessive conditioning causes leaves to dry too fast and detachment where they were damaged (losses). If bales must be stored outside, excessive crushing of their stems will promote the absorption of moisture. Insufficient conditioning can also cause deterioration, especially when dealing with products from trees or other robust stems.

NOTE: Products that are too dry and slippery, sometimes encountered in corn stalks, some herbs and a variety of wheat straw, can be baled in a satisfactory manner if the product is long enough to hold the bale together.

## Preparing silage for pressing

The product can be cut and prepared with the usual equipment such as a rotary mower or lawn mower and a tedder rake.

Produce uniform swaths. Flat, complete swaths are preferable. The best store results are obtained when the pressed product contains 40-50% dried product.

## Preparing straw for baling

If possible, make sure that straw is not chopped excessively by combine harvester threshing at the time of wheat harvest. If straw is already very dry and short, do not

remove the first baling swath. A full, correct size swath produced by a large combine harvester gives better results than a small one.

### Adjusting pick-up wheels

**IMPORTANT:** The pick-up collector teeth must never touch the ground. Therefore, adjust the working height of the pick-up in such a way that collector teeth remain raised a minimum of 2-3cm (1in) from the ground.

The working position of the pick-up should be adjusted by means of the side supporting wheels in one of the foreseen positions and the same on both sides.

#### Adjusting pick-up working height:

Raise or lower the pick-up working height by changing the position of the cotters "S" on the wheel arm, inserting them into one of the holes located on the support structure, according to your working needs.



To lower or raise the pick-up, use the tractor selector lever, opening the stop valve located near the quick coupling (position: "OPEN").

**OPEN**



**IMPORTANT:** Insert the pin "S" in the same position on both the right and left sides of the pick-up.

### Rake

Verify the height of the front baffle rake with respect to the pick-up bands.

- Position the rake in the lower hole, "min", for damp collection and small swaths.
- Position the rake in the upper hole, "max", for dry collection and large swaths.

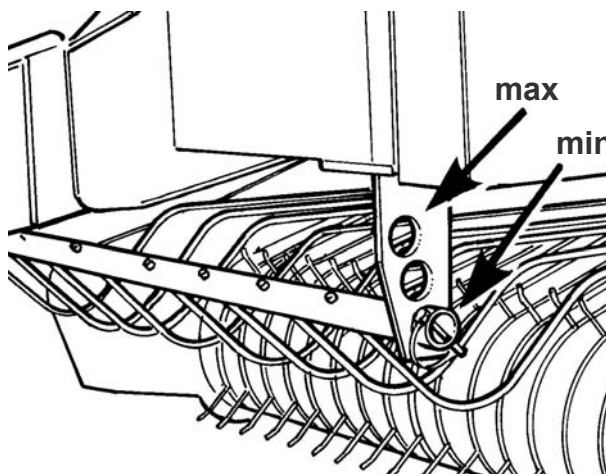

### Bale density

Pressure can be increased for dry products and decreased for moist products depending on the characteristics of the product to be collected.

To do this, turn knob "P" on the gauge **ONLY IF THE PRESSURE GAUGE IS NOT PRESSURISED** and set the desired pressure, which will be indicated by reference "R".

During the working phase, if the machine doesn't reach the set value for the working pressure (shown as "R" in the picture), you have to correctly adjust the value with hydraulic valve.

**Please contact your Dealer to perform this operation.**

**IMPORTANT: NEVER EXCEED A PRESSURE OF 190bar (19,000 kPa)**

**Exceeding maximum pressing pressure damages the machine!**

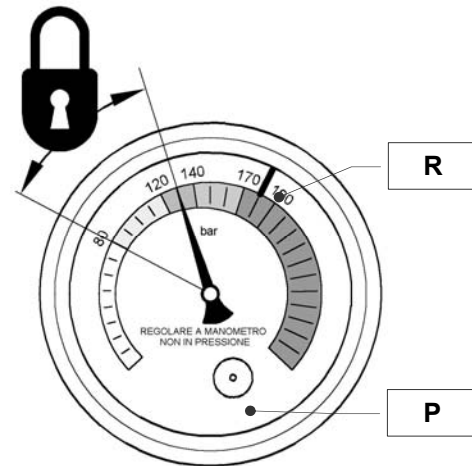

max pressure 190bar (19,000 kPa)

### Product feeding

#### Swath width equal to collector width

This is an ideal width swath.

The swath must be uniform, with little or no ridge. Excessive ridge leads to the production of barrel-shaped bales.

Swaths that have a width equal to that of the collector are the best as they do not require a serpentine or crossed passage.

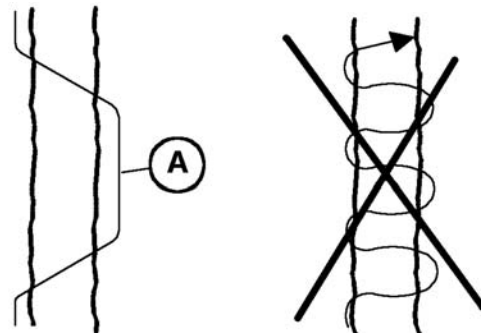

A = period of advancement in line

#### Tight swath

Feed product on one side of the collector for 6÷8 seconds. Then, steer over the swath and feed the product on the opposite side for the same interval. Reduce the period of advancement in line (A) for heavy swaths and increase for light swaths.

Bales formed in this way will be more uniform than those formed with a continuous serpentine movement of the tractor, as shown. Continuous shifting causes an excessive accumulation of material at the centre of the bale.

#### Medium sized swaths

If possible, avoid medium sized swaths.

When the operator drives in a zigzag over a swath of this type to direct the product at the ends of the collector, the product is continuously fed towards the centre. As a result, the material may be more concentrated at the centre of the bale than at the ends. The result is the formation of barrel-shaped bales.

### **Short, dry, smooth product bales**

In case of obstruction, attempt one of the following:

- Lift the collector to maximum.
- Reduce tractor PTO regime.
- Reduce the density of bales when necessary.
- Make wider swaths (add as needed).
- Replace broken collector teeth.

### **Use of the baler on corn stalks**

To prolong the life of collector teeth, cut stalks before pressing.

To increase feeding opening, lower the collector (teeth must not touch the ground).

Do not join more than six rows at a time as not to cause blockages in the collector area. Increased productivity can be obtained by baling smaller swaths at a faster advancement speed.

Make sure that rated PTO regime is maintained.

### **Use of the baler with silage and wet products**

Always start the bale with the collector centred on the swath.

Before entering onto a swath, reduce engine speed of the tractor to a minimum low. Choose a gear which allows for advancement speed of 6 to 10 km/h (46 mph) with the PTO at rated regime.

To ensure regular feeding, make sure that the towing bar does not touch the swath.

**Manual declogging / removal of product**



**DO NOT RISK.** Never use any kind of tool or key on the shaft while the tractor engine is running.  
Never attempt to remove forage from the machine while it is moving.

**Before any declogging operations:**

- Stop the tractor, remove the keys from the dashboard and wait for all moving parts of the machine to come to a complete stop.
- Switch off the " Electric Control" system.
- Always remove the equipment from the shaft as soon as you are finished using it.

- 1) Remove the pins "S" fastening the rake in order to remove forage obstructing the front part.

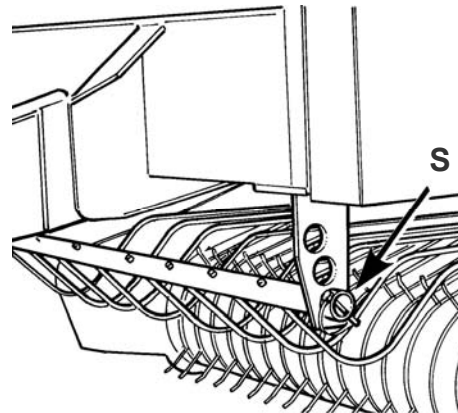

- 2) Then lift the hatch.
- 3) Block both jack rods with appropriate catches, inserting safety pins as well.

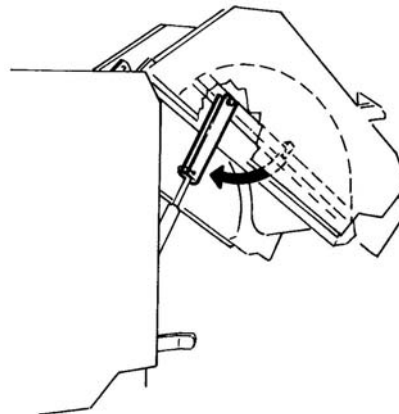

- 4) Then remove the product from inside the bale forming chamber.



**Never attempt to remove forage from the machine while it is moving.**

### Twine binder adjustment

The binding distance from the edge of the bale is regulated by two stops located at the outer ends of the binder.

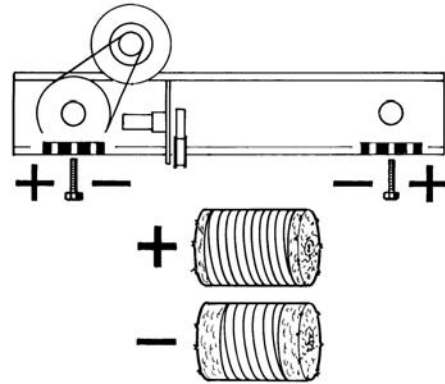

Bale binding can be more or less dense and is regulated by a variable diameter pulley:

- To obtain a dense binding, turn knob "M" counter-clockwise. In this case, the belt will position on the smallest diameter.
- To obtain thinner binding, turn knob "M" clockwise. In this case, the belt will position on the largest diameter.

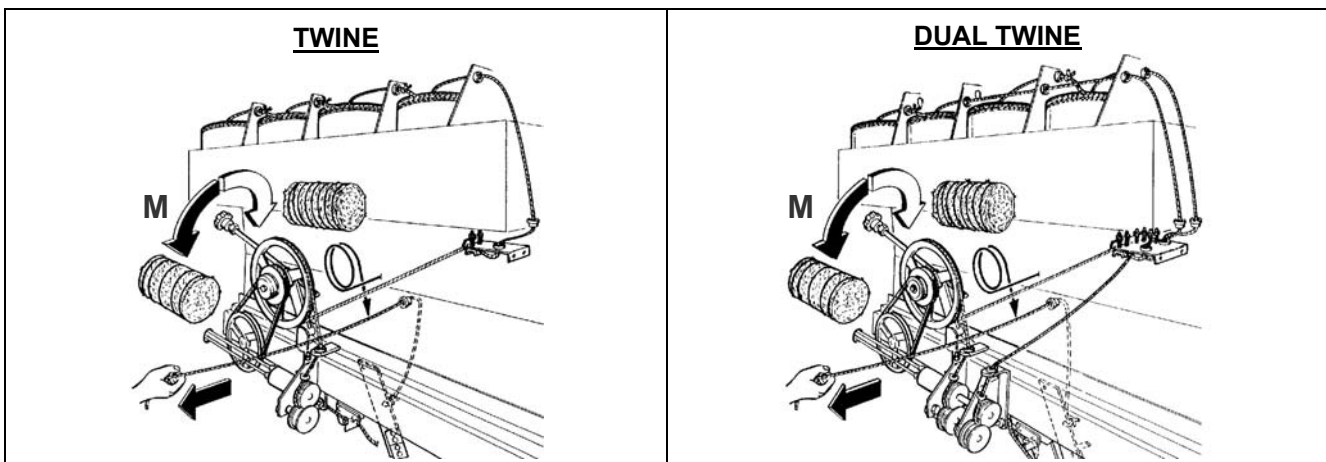

It is, however, possible to use all intermediate positions as needed.



### **CAUTION!**

Do not start work without guards in place.

### Net binder adjustment

Net rolls can be stopped appropriately by hooking the spring tensioners "T" of the side springs in the provided holes.

**If the reel is too firmly stopped, the driver rollers will not be able to unwind the net.**

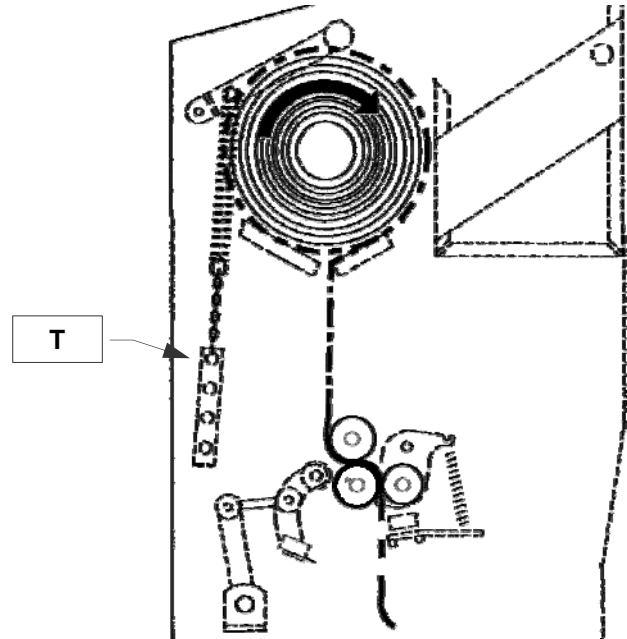

To adjust the number of net binds with which you want to wrap the bale, open the side left cover and select the hole corresponding to the number of binds to be used.

The contact pressure of the net feeding rollers can also be adjusted using the spring tensioners "M" on the side:

- If there is excessive pressure between the rollers, the net will tend to shrink towards the centre and the bale will not be wound for the entire width.
- If the opposite happens, if pressure is insufficient, rollers will not be able to unwind the net.

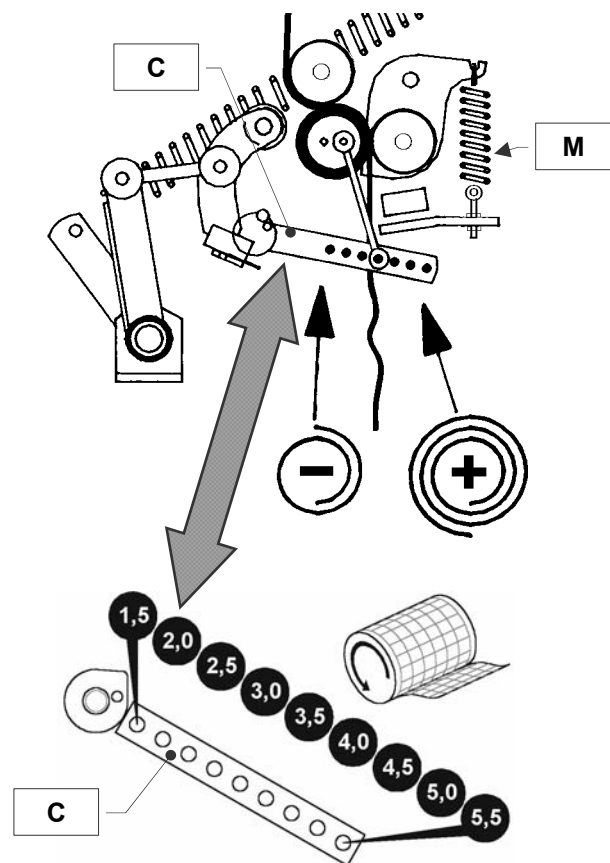

If during the binder, the net does not stretch completely and remains too inside the bale, you can remove (1) or position (2) the two catches of tying wire at the ends of the binder, to avoid having to cut or break the network.

Replace or reposition the two stoppers for reuse tying thread.

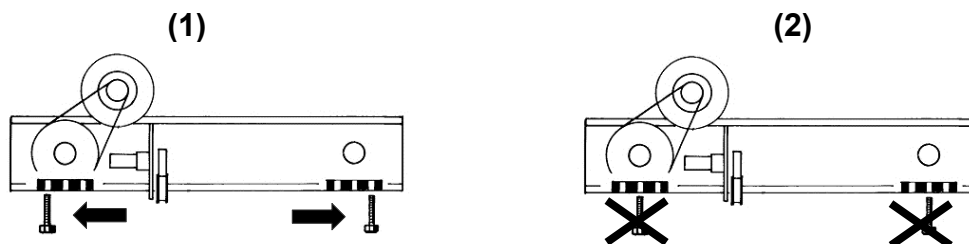

If during the binder, the net does not stretch completely and remains too inside the bale, you can position the stretch-net into the lower holes as shown in the pictures.

Place the stretch-net in the same holes on both left and right sides of the machine.

Left side

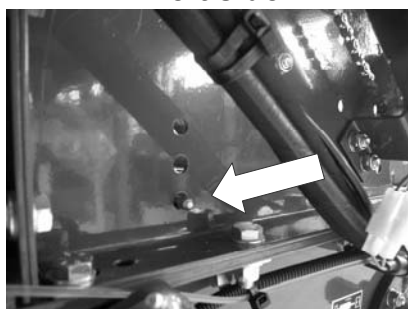

Right side

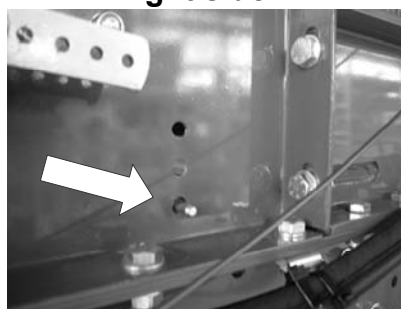

 **CAUTION!**

Do not start work without guards in place.

### Hatch safety catch

 **CAUTION!**

Before working on inside or around the baler with the hatch open, lock both jack rods (one on the right side and one on the left side) with suitable catches, inserting the safety pin.

Always comply with safety regulations when the hatch is open.

Close the hatch when you move away from the machine.

**IMPORTANT:** Remember to remove both safety catches from the hatch (one on the right side and one on the left side) before closing it to prevent causing serious damage to the machine structure!

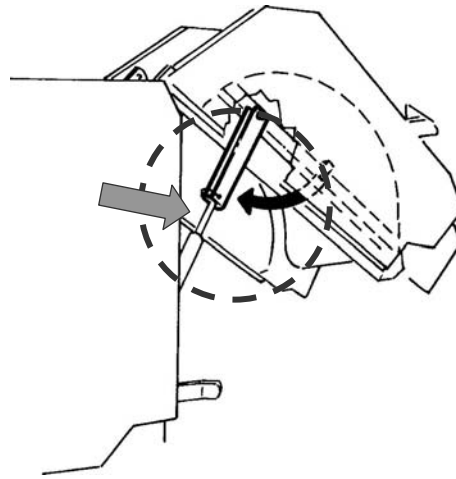

### Forming a bale



**DO NOT RISK.** To avoid being dragged into the machine, resulting in serious injury or death:

- Do not attempt to hand feed product or twine into the baler or to unclog the feeding area while the baler is in movement. The machine feeds product faster than it can discharge it.
- Disengage the PTO and stop the machine.

Before starting work, verify that the binder arms (twine or net) are in the resting position and that their respective cutting devices are unloaded.

Position yourself on the swath, open the pick-up stop valve ("OPEN" position) and lower.

**IMPORTANT:** Make sure that the hatch is closed, visually checking the pressure gauge. It must be between the yellow and the green sector and, however, must indicate a pressure of between 80÷130 bar (8000÷13000 kPa).

Check the height of the front baffle rake compared to the bands of the pick-up, depending on your work needs.

Set the pressure value depending on your work needs.

**IMPORTANT:** NEVER EXCEED a pressure of 190bar (19,000 kPa). Exceeding maximum pressing pressure damages the machine!

Engage PTO, operate the tractor at rated PTO regime and then start to feed the baler as described in "Product feeding" in the "Baler use" section".

### Binding and unloading bales

When the bale is complete, the red light on the system control terminal will light up and an acoustic warning will be heard, because the black pointer on the gauge will arrive at the red mark "R" (value pre-set using adjustment knob "P") and you will need to start binding manually.

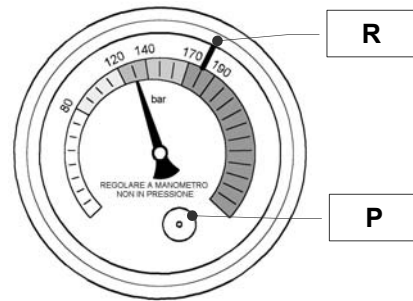

At this point, while the machine continues to go over the swath and loading the product, activate the binding button on the "Electric Control" terminal according to the type of binder in use, as described in paragraphs:

- TWINE binder operation
- NET binder operation

For very short products, a second binding with twine or dual twine may be useful:

- Pull the rope "F", avoiding cutting the twine at the first binding round of the twine-guide carriage "C" by the blade "L" and allow the carriage to perform a second binding.
- After the carriage first binding round by the blade "L", release the rope "F" to allow the twine to be cut at the end of the second binding cycle.

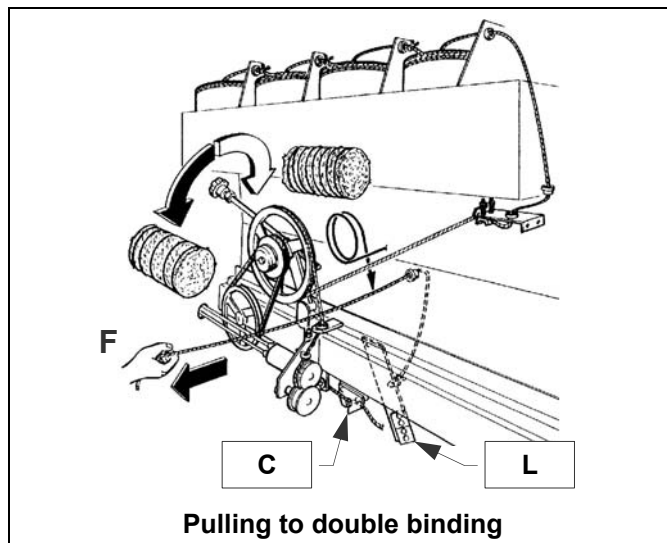

**IMPORTANT!:** The twine stop must put up a resistance to twine sliding, by about 1kg, achieved by tightening or loosening the screws compressing the springs.

After binding has been completed, open the hatch to eject the bale onto flat ground and not near people, then re-close the hatch.

When opening the hatch, a releasing gear is operated automatically, separating the catenary transmission.

**It is recommended to decrease the PTO shaft speed during the opening and closing phases of the hatch.**

**IMPORTANT:** Make sure that the hatch is closed, visually checking the pressure gauge. It must be between the yellow and the green sector and, however, must indicate a pressure of between 80÷130 bar (8000÷13000 kPa).

If the working pressure exceeds the set value closing the tailgate and with a low PTO speed, you have to adjust the value with the hydraulic valve.

**Please contact your Dealer to perform this operation.**

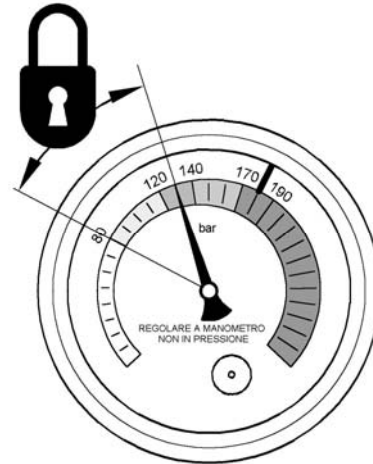

#### Bale ejector (optional kit)

Two bale ejectors (code 5FBZJDP0019) can be assembled on the hatch in position "E" on both sides.

These ejectors facilitate the ejection of bales when the product is wet or for silage.

**In other cases, ejectors are not useful and therefore should not be assembled.**

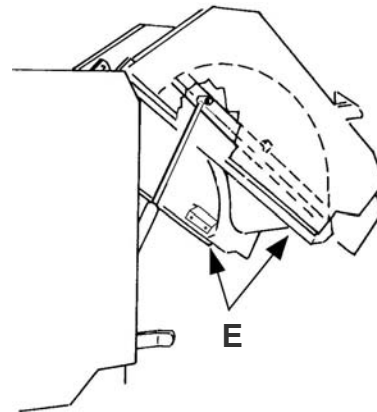

#### Resetting the mechanical bale counter

Reset the bale counter using the knob (A). When resetting the counter, perfectly align the number "0" (B), otherwise the bale counter will not operate properly.

**A = Knob**

**B = Numbers**

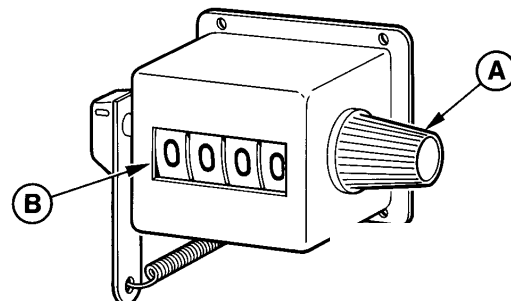



## USE OF THE "ELECTRIC CONTROL" CONTROL DEVICE

### "Electric Control" control system

The "Electric Control" control unit, installed inside the tractor cab and on hand for the operator, allows access to different control and bale binding functions.

The control unit is equipped with:

- An indicator light for warnings, buttons for activating various devices,
- an acoustic signal,
- an outlet for connecting to the machine cable.



### On/Off button

The On/Off button switches the terminal on and off.



### Twine binder button

The TWINE binder button activates the electric motor that activates the twine-holder pulleys.



### Net binder button

The NET binder button activates the electric motor that activates the net driver rollers.



### Indicator light

The indicator light switches on to call attention together with an acoustic signal.



### TWINE binder operation

- 1) When the gauge reaches the setting (bale formed), the “**STOP**” indicator light will go on together with an acoustic signal.
- 2) At this point, press the **TWINE binding** button and hold until the twine is pulled from bale rotation into the forming chamber.

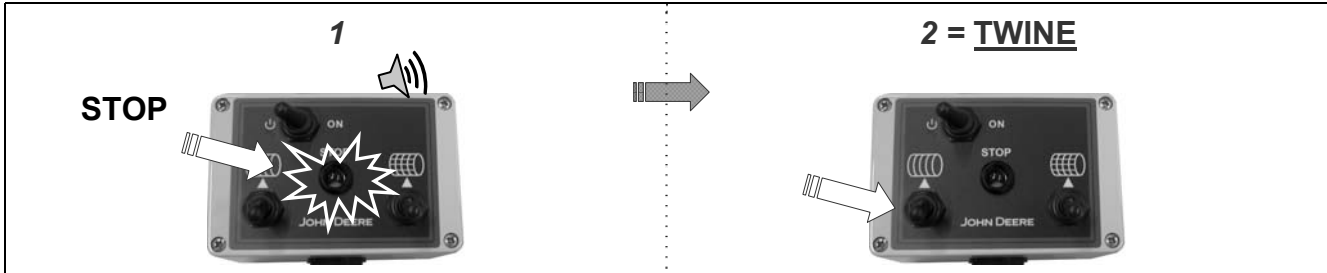

Wait for the carriage to fully complete its action before cutting twine.

### NET binder operation

- 1) When the gauge reaches the setting (bale formed), the “**STOP**” indicator light will go on together with an acoustic signal.
- 2) At this point, press the **NET binding** button and hold until the twine is pulled from bale rotation into the forming chamber.

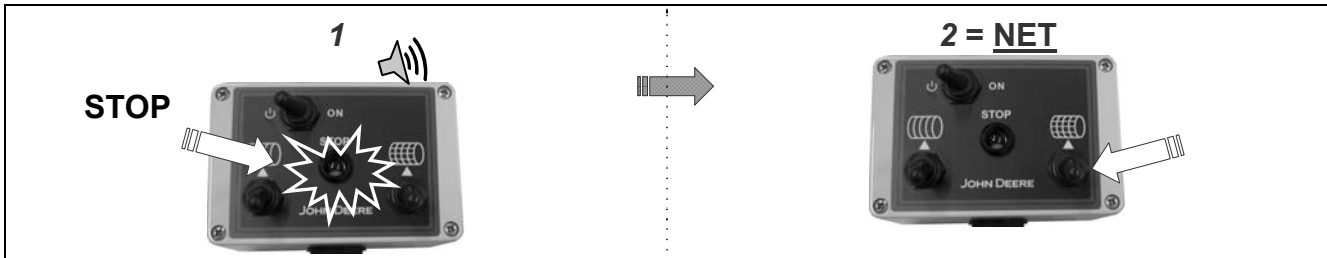

The binder will automatically complete the binding cycle until the net is cut and will remain in stand-by ready for next binding.

## **ATTACHMENTS**

A series of accessories and kits, to be applied to the machine upon request, can be used to improve binder performance and operations.

Consult your Dealer or our Spare Parts Service department to verify which accessories and/or kits are most suitable for the baler model you have purchased.

### **Accessories**

Includes all optional devices which, if requested upon purchase of the baler, are assembled on the machine by the Manufacturer:

- Net binder.
- Tyres.

### **Kits**

Includes all those optional devices that can be purchased and assembled later by the operator. Said kits come with the necessary instructions for assembling and disassembling them from the machine any time necessary, based on your working needs:

- Bale chute.  
Facilitates moving bales away from the hatch closing range once ejected (not recommended on sloping ground).
- Cardan shafts.



## LUBRICATION AND MAINTENANCE

### Safe machine lubrication and maintenance

**IMPORTANT:** Regular and careful maintenance extends the life of your machine and ensures your safety.

#### CAUTION!

Before performing any maintenance operations on the machine, take heed of all basic safety regulations, as contained in chapter "General safety standards".

To avoid injury from unexpected movement, perform maintenance on machines supported firmly on flat, horizontal ground.

Do not lubricate or perform maintenance while the machine is in movement. Carry out all maintenance operations with the machine switched off and after all moving parts have come to a complete stop:

If the machine is connected to the tractor, engage the tractor parking brake, stop the engine and remove the key. Always switch off the "Electric Control" system.

If the machine is disconnected from the tractor, block the wheels to prevent movement.

Never lift the machine from the ground.

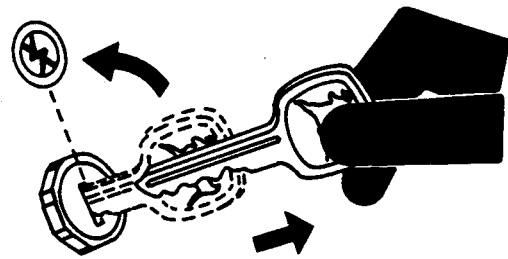

#### CAUTION!

If you should need to perform maintenance with the machine hatch open or inside the bale forming chamber, block the hatch using the hatch locking safety device.

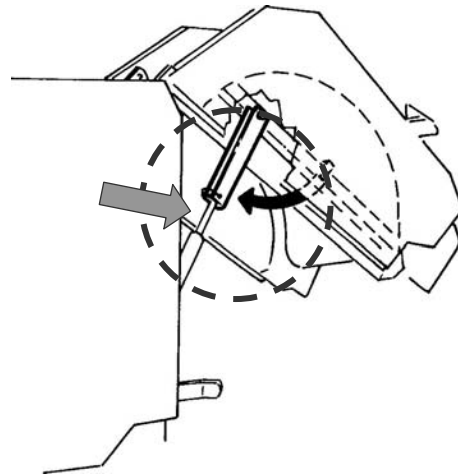

### Compliance with maintenance intervals

Using the tractor hour counter as a guide, perform maintenance at the intervals indicated on the following pages.

**IMPORTANT:** Recommended maintenance intervals refer to normal operating conditions. Perform maintenance **MORE FREQUENTLY** if the baler operates in adverse conditions.

### Performing lubrication and maintenance

Clean grease fittings before using the grease gun. Immediately replace any broken or missing fittings. If a new fitting is not able to receive grease, remove and check connected parts.

## Grease

Depending on the environmental temperature expected during the period of use, use a grease with a suitable NLGI (consistence) number.

**Preferably, use John Deere SD POLYUREA GREASE.**

The following greases are also recommended:

- John Deere HD LITHIUM COMPLEX GREASE
- John Deere HD WATER RESISTANT GREASE
- John Deere GREASE-GARD™

You can use other greases which conform to the following standards: NLGI Performance GC-LB Classification

**IMPORTANT:** Some types of grease thickeners are not compatible with others. Before mixing other types of greases, consult with your supplier.

*GREASE-GARD is a trademark of Deere & Company.*

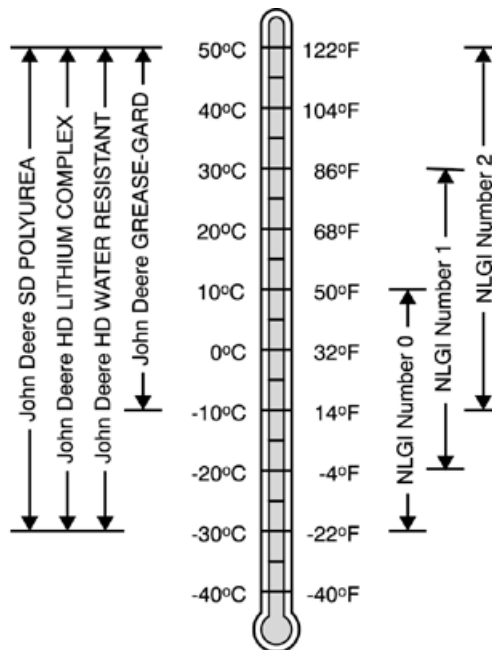

## High-viscosity oil for gearboxes

Use a high-viscosity oil suitable for the temperatures expected between one oil change and another.

We recommend using John Deere HY-GARD™ (high-viscosity).

Other oils can also be used as long as they meet John Deere JDM J20C standards.

We do not recommend the use of low viscosity oils such as John Deere HY-GARD™ and BIO-HY-GARD™.

*HY-GARD is a trademark of Deere & Company*

*BIO-HY-GARD is a trademark of Deere & Company*

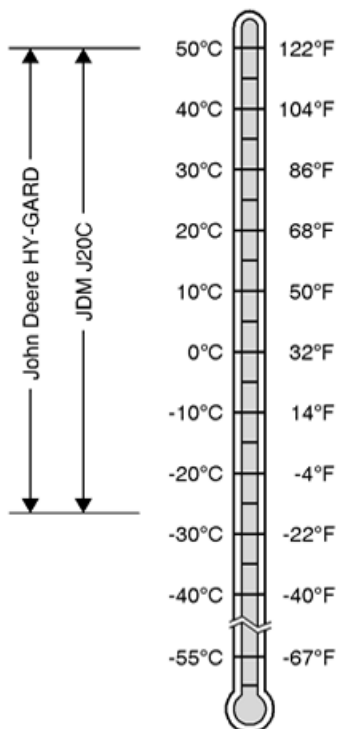

### Oil for Multiluber chains

Use the following oil for Multiluber chain lubrication systems: John Deere BIO-MULTILUBER-OIL<sup>1</sup>

Other equivalent biodegradable oils can also be used.

**IMPORTANT: Never use mineral oils for this use.**

**NOTE:** John Deere BIO-MULTILUBER-OIL oil is available at John Deere resellers.

- DC43300: BIO-MULTILUBER-OIL 5 litres
- DC44063: BIO-MULTILUBER-OIL 25 litres

<sup>1</sup> John Deere BIO-MULTILUBER-OIL meets or exceeds the requirements of biodegradability of 80% in 21 days, according to test method CEC-L-33-T-82. BIO-MULTILUBER-OIL must not be mixed with mineral oil.

### Alternative and synthetic lubricants

Conditions in certain geographical areas may require lubricants other than those specified in this manual.

Some types of coolants or lubricants may not be available in your area.

For advice or information, please consult your **John Deere** dealer.

Synthetic lubricants can be used as long as they meet performance requirements.

Re-refined products can be used if the lubricant meets performance requirements.

### Lubrication storage

Your equipment can operate at top efficiency only if clean lubricants are used.

Use clean containers when transferring lubricants. Store lubricants and their containers if possible in an area free from dust, humidity and other contaminants. Store containers on their side to avoid accumulating water and dirt on caps.

Ensure that all containers are properly labelled to identify their contents.

Properly dispose of all old containers and any residual lubricant.

### Alternative and synthetic lubricants

**IMPORTANT: Observe laws in your country concerning the use and disposal of oil and/or lubricants.**

Your equipment can operate at top efficiency only if clean lubricants are used.

Use clean containers when transferring lubricants. Store lubricants and their containers if possible in an area free from dust, humidity and other contaminants. Store containers on their side to avoid accumulating water and dirt on caps.

Ensure that all containers are properly labelled to identify their contents.

Properly dispose of all old containers and any residual lubricant.

### Lubrication mixing

In general, avoid mixing different brands or types of oil. Oil manufacturers blend additives in their oils to meet certain specifications and performance.

The mixing of oils can interfere with the behaviour of these additives and degrade the characteristics of the lubricant.

For advice or information, please consult your **John Deere** dealer.

### Automatic chain oiling regulation

The baler is equipped with an automatic oiling system for chains.

This system works every time the hatch is closed by means of pump movement.

The flow of oil can be regulated by directly adjusting the stroke of the piston "P" located on the pump.

If the quantity of oil output is low or too high, adjust the distance "D" as to increase or decrease the stroke of the piston on the pump.

- Open the left side cover and position yourself so you are able to reach the automatic oiling pump, located directly under the hinge of the cover itself.
- Loosen the Allen screws "V" and slide the pump along the slots to increase or decrease the stroke of the piston "P".

**The LOWER the stroke of the piston "P" is, the higher the oil pumped and circulated by the automatic chain lubrication system.**

**The HIGHER the stroke of the piston "P" is, the lower the oil pumped and circulated by the automatic chain lubrication system.**

**THE MINIMUM PERMITTED STROKE IS 10mm.**

- After regulating, retighten the two Allen screws and close the left side cover.

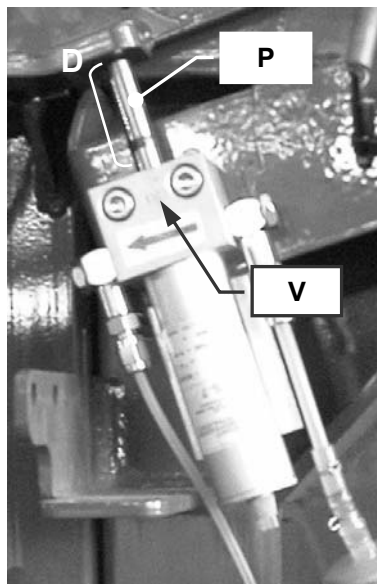

### Tank

Periodically check and top up oil in the automatic chain oiling tank:

- Open the left side cover.
- Unscrew plug "T", fill the tank with oil and replace plug "T."

**OIL TANK CAPACITY IS 1.5 LITRES.**

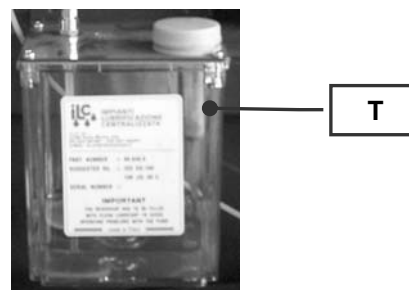

### Filter (annually)

Periodically check the conditions of the automatic chain oiling system filter.

If it needs replacement:

- Open the left side cover.
- Loosen clamps "F" and replace with new of the same.
- Retighten the 2 clamps "F".

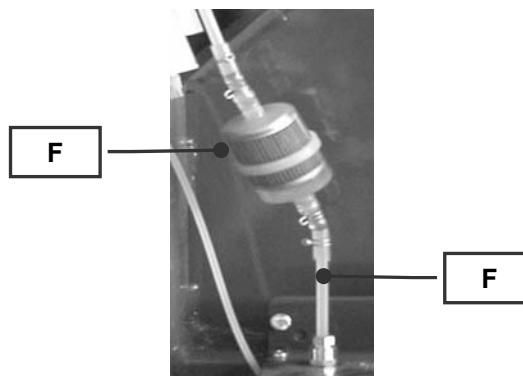

**Gear box oil level (30 working days)**

**IMPORTANT:** Periodically check the oil level in the gear box at the beginning of each season.

**Do not overfill the gearbox so not to cause overheating or loss of oil.**

**Use oils recommended by John Deere.**

Depending on the type of box mounted on your machine, periodically check the oil level in the gear box by means of the plug located on the back of the box and visible from the rear hole of the front cross member of the machine.

If oil leaks from the box, or if it is located at the same level of the plug hole, this means that the oil level is correct.

**COMER type box**

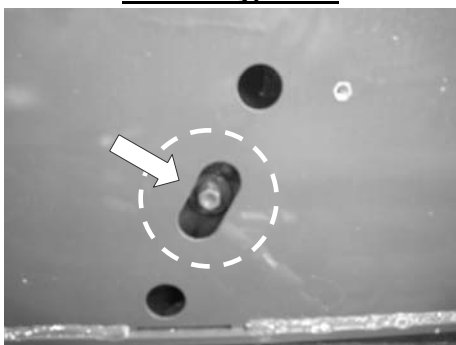

**BYPY type box**

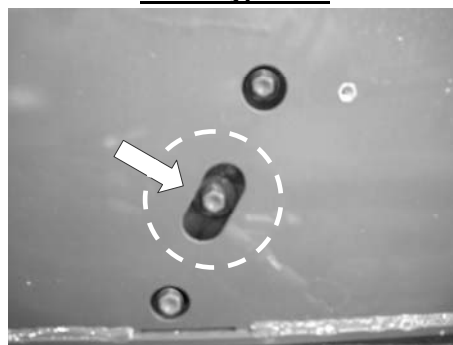

After having checked the oil level inside the gear box, close the plug.

### Draining and refilling the gear box (annually)

**IMPORTANT:** Change gear box oil after the first 50 working hours and then at the beginning of every season.

Do not overfill the gearbox so not to cause overheating or loss of oil.

Drain oil while it is still hot (for example, after machine use).

### Draining oil

#### 1st way (with a COMER box):

- Obtain a container to collect the oil to be drained.
- Position it under the machine and unscrew and remove the plug located on the front of the box.
- Empty oil from the box, collecting it in the container that you set prior.
- After having emptied oil from the gear box, close its drain hole with the plug.

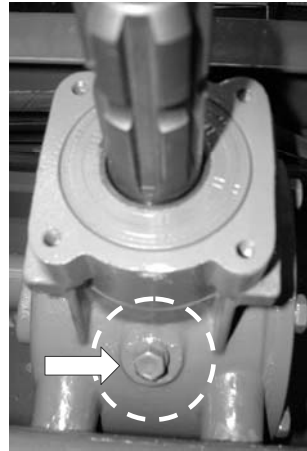

#### 2nd way (with a BYPY box):

- Obtain a container to collect the oil to be drained.
- Unscrew and remove the plug located on the lower part of the box and visible from the rear hole of the front cross member of the machine.
- Empty oil from the box, collecting it in the container that you set prior.
- After having emptied oil from the gear box, close its drain hole with the plug.

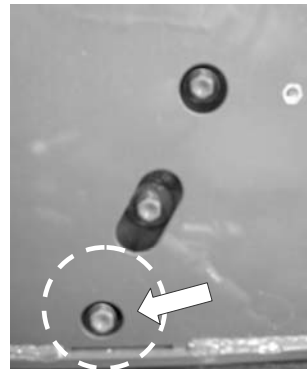

### Topping up oil (annually)

**IMPORTANT:** Top up oil at the beginning of each season.

If the quantity of oil contained in the gear box is insufficient, you will have to top it up.

**THE QUANTITY OF OIL NECESSARY IS 1.1 kg.**

Based on the type of gear box assembled on your machine, top up as follows:

#### 1st way (with a COMER box):

- Unscrew the screws and remove the protective cover on the gear box.
- Unscrew and remove the plug located on the upper part of the box and top up with oil in the box itself.
- After having topped up oil in the gear box, clean the plug and close.
- Replace the cover and retighten with the same screws.

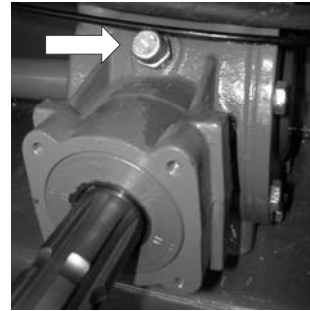

#### 2nd way (with a BYPY box):

- Unscrew and remove the plug located on the upper part of the box and visible from the rear hole of the front cross member of the machine. Top up oil.
- After having topped up oil in the gear box, clean the plug and close.

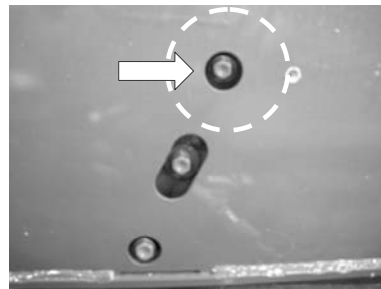

### Flexible hydraulic hoses (annually)

**IMPORTANT:** Check conditions of hydraulic hoses at the beginning of each season.

If conditions are not optimum, check more frequently.

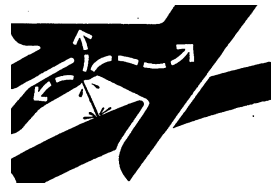

**IMPORTANT:** Due to the ageing of rubber, it is advisable to replace the hydraulic hoses every 5 years.

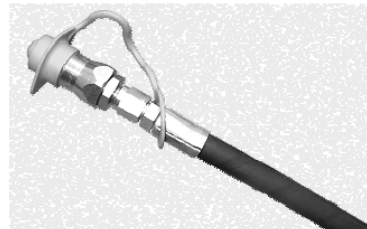

**Lubrication operations**

**IMPORTANT:** All operations described below must be performed at the beginning and end of each season.

Perform lubrication operations following all safety regulations as described in the chapter “Maintenance and adjustments”.

**Greasing points (30 working hours)**

Lubricate and grease all points indicated by the relative stickers: “7500214”, on the machine

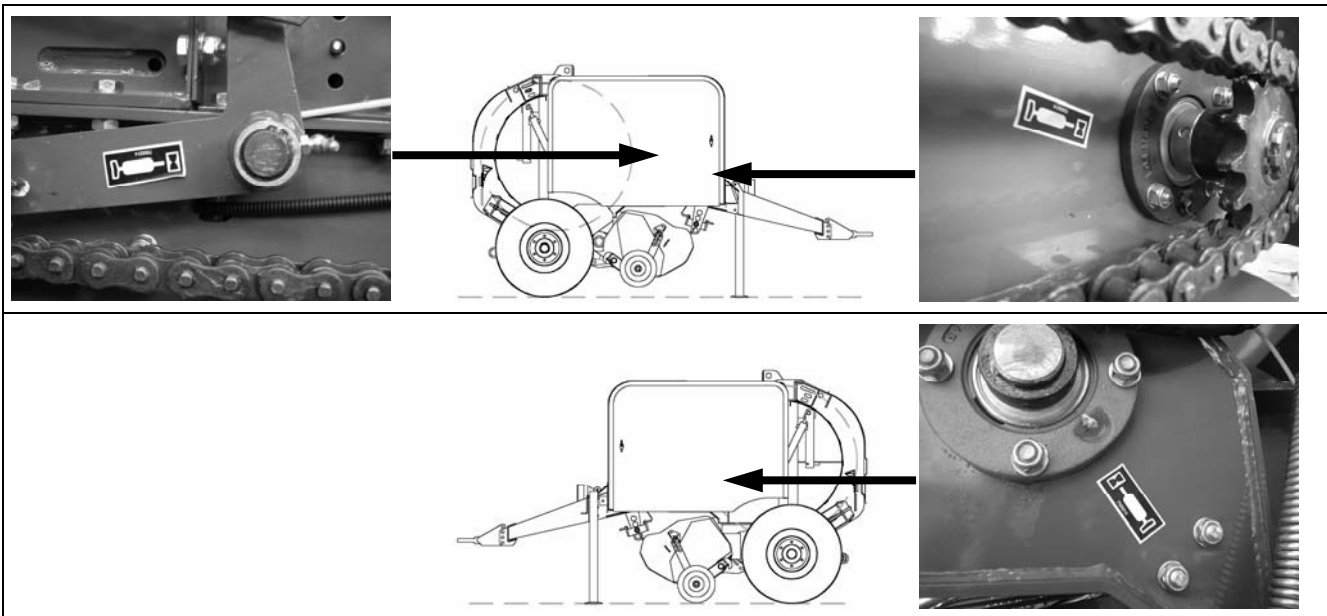
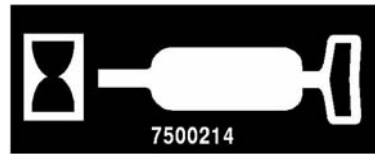

**Greasing cams (10 working hours)**

- Loosen the screws and remove the safety cover on the right side of the pick-up
- Insert the grease in the right hole to lubricate the pick up cam.

At the end of the operation, reassembly the safety guard and lock it again.

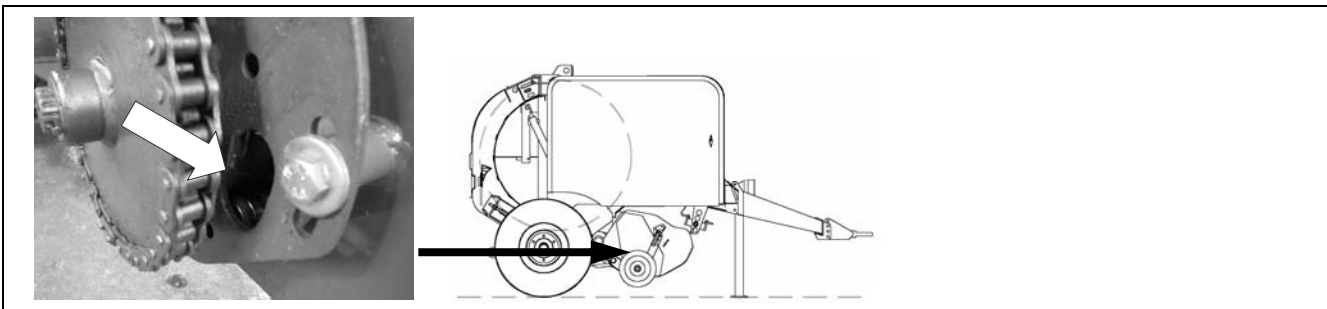

**Greasing the transmission shaft (30 working hours)**

Lubricate and grease the cardan shaft according to instructions contained in the use and maintenance manual supplied with the shaft itself.

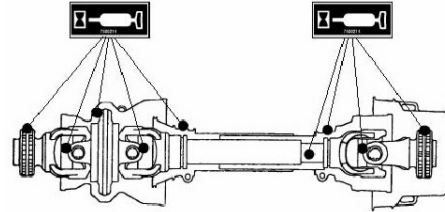

**Manual chain oiling (10 working hours)**

All the chains which are not oiled by the automatic oiling system must be manually lubricated using a solution composed of oil and grease.

Periodically verify and lubricate these chains, paying special attention to pick-up transmission chains.

**IMPORTANT:** In order to perform the pick up transmission chain manual oiling it's necessary to remove their guard protection.

At the oiling operation end, reassembly the safety guard and lock it again.

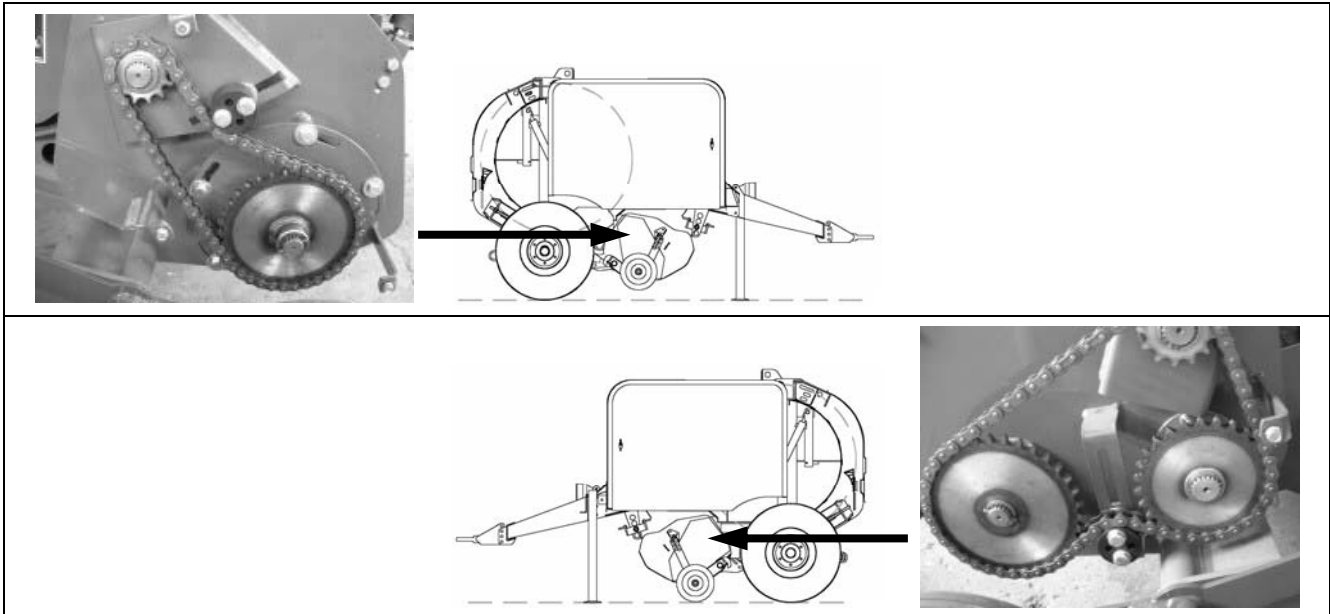

Open the lateral right guard and lubricate the net wrapping unit transmission chain.

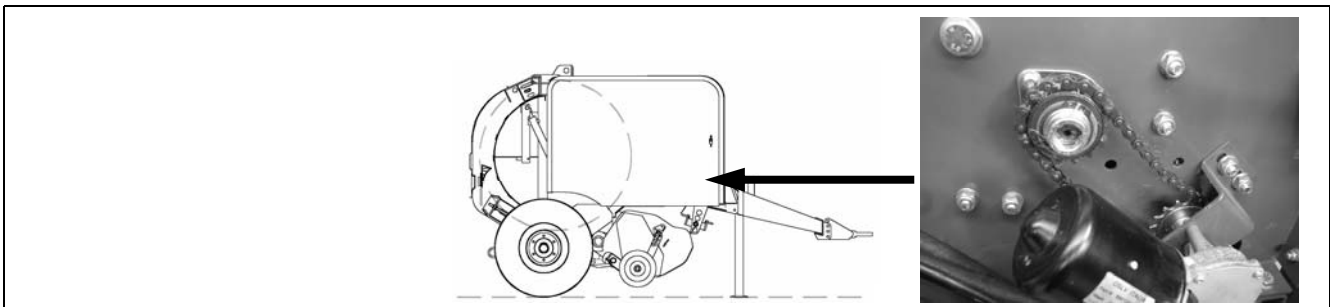

### Wheels and tyres (30 working days)

**IMPORTANT:** Repairs to wheels and tyres must be performed by qualified personnel who are equipped with proper tools.

Periodically check inflation pressure and verify it based on the type of tyre mounted on your machine.

**IMPORTANT:** Periodically check the tightening value of nuts on the wheel hub columns, which must be 230Nm (168 lb-ft)

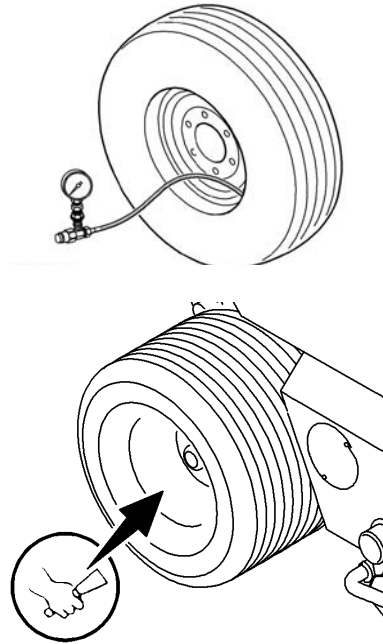

- Remove the wheels and clean bearings.
- Lubricate with John Deere GREASE-GARD.
- Replace and adjust bearings.
- Tighten nuts to the following value: 230Nm (168 lb-ft)

### Removing / assembling wheels



**Take extra care as wheel removal / assembly operations can be dangerous.**

To avoid injury from unexpected movement, support the machine firmly on flat, horizontal ground.

Take heed of all basic safety regulations, as contained in chapter "General safety standards".

**IMPORTANT!** To remove / assemble a wheel, use an adequate capacity jack to lift the machine.

**The machine load on the 1st axis is:**

- F440E = 1780kg (3924 lb)
- F450E = 2030kg (4475 lb)

Therefore, based on the wheel to be dismantled, position parking wedges under the tyres.



Position the appropriate jack and lift the machine from one side.



Remove the six screws fastening the wheel and remove.



Assemble the wheel and replace the six fastening screws to:230Nm (168 lb-ft)



## TROUBLESHOOTING

These tables summarise the most likely and recurring problems you may encounter while working. However, if the proposed solutions do not solve the problem, please contact your Dealer or our Customer Service directly, as they can provide technical advice necessary for the solution of the problem.

### Feeding

PROBLEM	POSSIBLE CAUSE	REMEDY
The collection assembly rotates but not the catenary.	The hatch is not closed.	Activate the hydraulic system and close the hatch.
	Release register to be adjusted.	Register the screw under the jack to the right of the hatch.
The pick-up will not raise or lower.	Pick-up pivot hinge not lubricated.	Lubricate the pivot hinge.
Product flooding in the feeding mouth.	Swaths too wide and irregular or advancement speed too fast.	Recreate swaths to correct proportions and advance slower.
	Swath collection too much to the side.	Collect regularly moving from one side to the other.
	rpm too low.	Work at 540 rpm
Collector teeth shooting forage.	Collector speed too high with respect to working speed.	Increase working speed.
		Reduce tractor PTO rpm.
Collector teeth surpassing arriving forage.	Collector speed too low with respect to working speed.	Reduce working speed.
		Increase tractor PTO rpm.
The collector not collecting the entire swath.	Swath too wide.	Recreate swath, making it tighter.
The collector not collecting on flat swaths.	Collector too high.	Lower collector using the tractor selector.
		Adjust collector supporting wheel position on the ground.
Collector slips and stops.	The safety bolt is broken.	Reduce the volume of the swath by dividing it.
		Lift the collector, adjusting the position of supporting wheels.
		Remove the obstacle and replace the safety bolt.
Insufficient product collection.	Collector teeth worn or missing.	Replace teeth.

**Bale formation**

PROBLEM	POSSIBLE CAUSE	REMEDY
Excessive transmission noise.	Chains loose or dry.	Lubricate chains.
The bale is not properly formed or in a cone shape.	Feeding mostly one-sided.	Collect regularly moving from one side to the other.
Chains coming off gear teeth.	Tensioners are loose.	Tighten chains by adjusting tensioners.
	Gears and chains are worn.	Replace gears or chains.

**Binding**

PROBLEM	POSSIBLE CAUSE	REMEDY
The twine comes off the bale.	Side twine limiters too far outside.	Position limiters inside.
Twine not being taken by bales.	Binding started without product on the pick-up collector.	Always collect with product on the pick-up.
	Twine stop too tight.	Loosen the twine stop clamps as needed.
The twine being pulled by the bale but the twine-guide carriage not moving.	The transmission belt sliding.	Oil the moving parts of the variable pulley.
Twine not being cut.	Cutting blade worn.	Turn or replace the cutting device blade.
	Twine not going past the cutting device blade.	Register the blade-holder arm stop screw.
The net is not properly distributed over the bale.	Net mesh too wide.	Use a standard net.
	Improper net movement.	Verify that you properly inserted the net.
	Improper reel stop.	Turn side spring tensioners.
	Excessive or insufficient pressure between rollers.	Turn side spring tensioners.
The net is torn or is wound on the starter roll.	Make sure there are no burrs or dirt on the rollers.	Deburr rollers.
	Make sure there is no residual material or sticky areas on the rollers.	Clean rollers with soap and water.
	the net does not stretch completely and remains too inside the bale.	Place the stretch-ne in the lower holes (both sides).
		Remove or adjust the stoppers of tying wire at the ends of the binder.

**Cardan shaft**

PROBLEM	POSSIBLE CAUSE	REMEDY
Clutch slipping.	The bale is too heavy or the diameter is too large.	Reduce bale weight or diameter.
	Clutch discs worn.	Replace discs (Follow operations described in the cardan shaft manual).
The safety bolt is broken.	The bale is too heavy or the diameter is too large.	Reduce bale weight or diameter.

**Hydraulic system**

PROBLEM	POSSIBLE CAUSE	REMEDY
The hatch will not close.	Visually check the gauge pointer.	It must be between the yellow and the green sector and, however, must indicate a pressure of between 80÷130 bar (8,000÷13,000 kPa).
	Forage has remained in the closing area of the hatch.	Remove forage.
	The hydraulic system return has been disengaged from the tractor.	Verify and properly insert the quick coupling of the hydraulic system return.
The hydraulic system is not working.	Hydraulic outputs have not been activated.	Activate the auxiliary hydraulic outputs from the tractor.
	Hydraulic tubes are not properly inserted in the auxiliary outlets of the tractor.	Verify and properly engage the quick couplings of the auxiliary outlets of the tractor.
	Insufficient flow of hydraulic oil.	Verify and, if necessary, top up hydraulic oil in the tractor tank.
	Pump worn or damaged (low pressure).	Repair or replace the tractor's hydraulic pump.
	Dirt has built up in the hydraulic circuit.	Drain or, if necessary, clean hydraulic oil filters.
	The gauge is broken.	Replace the gauge or its capillary tube.
	Jacks losing oil.	Replace jack seals.
	Oil leaking in the hydraulic system.	Check tubes and, if necessary, tighten fittings.
Pressure.	During the working phase, the baler doesn't reach the set pressure value	Adjust the pressure value with the hydraulic valve. Contact your Dealer to perform this operation.
	During the working phase, the set pressure value is exceeded	Adjust the pressure value with the hydraulic valve. Contact your Dealer to perform this operation.



## MAINTENANCE

**IMPORTANT:** All operations described below must be performed at the beginning and end of each season.

 **CAUTION!**

Before performing any maintenance operations on the machine, take heed of all basic safety regulations, as contained in chapter "General safety standards".

To avoid injury from unexpected movement, perform maintenance on machines supported firmly on flat, horizontal ground.

Do not perform maintenance while the machine is in movement. Carry out all maintenance operations with the machine switched off and after all moving parts have come to a complete stop:

If the machine is connected to the tractor, engage the tractor parking brake, stop the engine and remove the key. Always switch off the "Electric Control" system.

If the machine is disconnected from the tractor, block the wheels to prevent movement.

Never lift the machine from the ground.

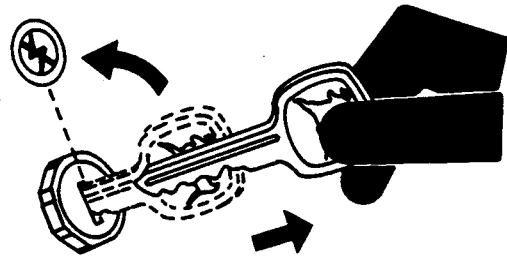

 **CAUTION!**

If you should need to perform maintenance with the machine hatch open or inside the bale forming chamber, block the hatch using the hatch locking safety device.

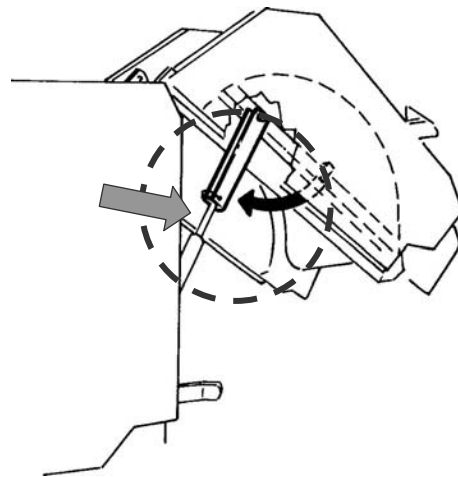

### Original spare parts

**IMPORTANT: USE ORIGINAL SPARE PARTS ONLY.**

Original John Deere spare parts are made taking into account the specific needs of John Deere equipment.

Spare parts made by other manufacturers are neither controlled nor approved by John Deere. The use of said components on John Deere machines may affect operations and compromise safety.

To prevent this risk, only use original John Deere spare parts.

**Welding (annually)**



**CAUTION!**

**RISK OF FIRE!** Never perform welding work on your baler with a bale in the chamber.

**Before performing any welding operations on your baler:**

- Stop the tractor, remove the keys from the dashboard and wait for all moving parts of the machine to come to a complete stop.
- Disconnect all electric and electronic functions.
- Switch off the control system.

**Replacing hydraulic components**



**CAUTION!**

Splashes of liquid under pressure can penetrate the skin and cause serious injury.

Relieve pressure before disconnecting hydraulic hoses or other lines. Tighten all joints before restoring pressure.

Use a piece of cardboard to identify leaks.

Protect hands and body from high pressure liquids.

Always remove hydraulic pressure before intervening on hydraulic components.

**IMPORTANT:** When removing or connecting hoses, use two wrenches to avoid twisting the hydraulic tubes.

Contact a doctor immediately if you are hit by a jet of fluid. Any fluid injected into the skin must be surgically removed within a few hours or gangrene may result. Medical personnel not familiar with this type of injury should consult a specialist.

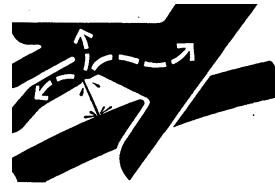

**Tightening bolts (annually)**

**IMPORTANT:** All assemblies with screws must be tightened according to the values contained in the table “Tightening torque table,” unless otherwise specified.

**IMPORTANT:** Verify bolt tightening after the first 3 hours of work or after the first 10 bales that the machine wraps.

**FOR THIS MACHINE, THE VALUE “8.8” REPRESENTS THE STANDARD AND THE MINIMUM QUALITY USED.**

**Diameter and tightening torques for material qualities according to DIN ISO 898.**

**Baler steering head**

Annually retighten the screws holding the frame of the steering head to 240Nm (175 lb-ft).

Annually retighten the screws holding the towing eye to 475Nm (350 lb-ft).

**Tightening torque table**

Bolt Ø	Class 4.8				Class 8.8 or 9.8				Class 10.9				Class 12.9			
	Lubricated <sup>a</sup>		Dry <sup>b</sup>		Lubricated <sup>a</sup>		Dry <sup>b</sup>		Lubricated <sup>a</sup>		Dry <sup>b</sup>		Lubricated <sup>a</sup>		Dry <sup>b</sup>	
Dimensions	N m	lb-in	N m	lb-in	N m	lb-in	N m	lb-in	N m	lb-in	N m	lb-in	N m	lb-in	N m	lb-in
M6	4.7	42	6	53	8.9	79	11.3	100	13	115	16.5	146	15.5	137	19.5	172
M8	11.5	102	14.5	128	22	194	27.5	243	32	23.5	40	29.5	37	27.5	47	35
M10	23	204	29	21	43	32	55	40	63	46	80	59	75	55	95	70
M12	40	29.5	50	37	75	55	95	70	110	80	140	105	130	95	165	120
M14	63	46	80	59	120	88	150	110	175	130	220	165	205	150	260	190
M16	100	74	125	92	190	140	240	175	275	200	350	255	320	235	400	300
M18	135	100	170	125	265	195	330	245	375	275	475	350	440	325	560	410
M20	190	140	245	180	375	275	475	350	530	390	675	500	625	460	790	580
M22	265	195	330	245	510	375	650	480	725	535	920	680	850	625	1080	800
M24	330	245	425	315	650	480	820	600	920	680	1150	850	1080	800	1350	1000
M27	490	360	625	460	950	700	1200	885	1350	1000	1700	1250	1580	1160	2000	1475
M30	660	490	850	625	1290	950	1630	1200	1850	1350	2300	1700	2140	1580	2700	2000
M33	900	665	1150	850	1750	1300	2200	1625	2500	1850	3150	2325	2900	2150	3700	2730
M36	1150	850	1450	1075	2250	1650	2850	2100	3200	2350	4050	3000	3750	2770	4750	3500

The values given above are for general use only and are based on the strength of the screw or bolt. DO NOT use these values if a different torque value is prescribed or for a different tightening procedure for a specific application. For stainless steel screws or nuts on U-brackets, see tightening instructions for specific applications. Tighten the plastic insert or crimped steel lock nuts and tighten the nut to the dry torque shown in the table, unless different instructions have been given for a specific application.

Safety catches are designed to break when subject to certain loads. Always replace them with identical class safety screws. Replace screws with others of the same class or higher. If using a higher class of screw, it must be tightened to the torque of the original screws. Make sure that bolt threading is clean and that bolts are perfectly inserted. If possible, lubricate bare or galvanised bolts (with the exception of locking nuts, bolts or wheel nuts), unless different instructions have been given for a specific application.

<sup>a</sup> "Lubricated" means coated with a lubricant such as motor oil, fasteners with phosphate or oil coating, or M20 or higher fasteners with galvanising.

<sup>b</sup> "Dry" means regular or zinc plated without any lubrication, or M6 to M18 galvanised fasteners.

**Tensioning chains (30 working days)**

**IMPORTANT:** Regularly check transmission chain tension and, where present, the functioning of the automatic tensioners.

The value "F" of chains tensioning must be equal to 5-10 mm (2÷4 in).

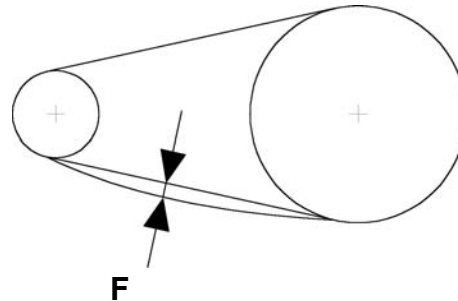

**Adjusting automatic tensioners**

The machine roller chains are tensioned automatically by spring tensioners. Periodically check proper chain tensioning and restore when necessary.

Check automatic tensioner functioning.

In order to verify and adjust chain tension:

- Open the right side cover.
- Use the nut to adjust chain tension.
- Close the right side cover.

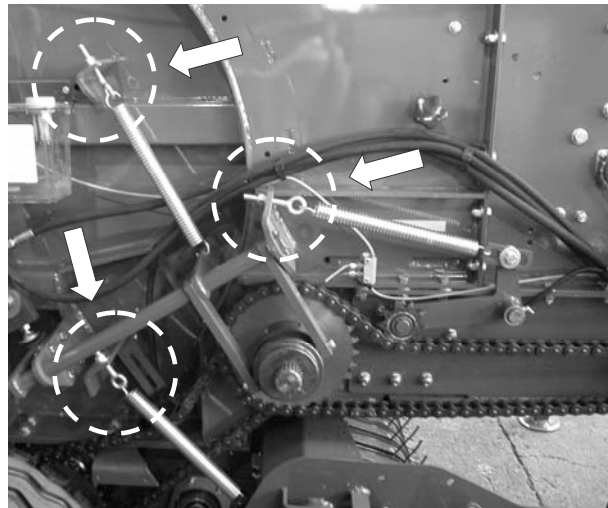

**Adjusting manual tensioners**

Some machine roller chains are tensioned manually by tensioners. Periodically check proper chain tensioning and restore when necessary.

To check and adjust chain tensioning, open the right and left side covers (close the covers once the adjustment(s) made is complete).

**Transport roller chain tensioning (left side)**

- Loosen screws and remove the safety cover on the left side.
- Loosen the three screws "V" and, with the help of a hammer, adjust chain tension, moving the tensioner upward with small strokes.
- Once adjusted, re-tighten the three screws "V".
- Replace the safety cover and re-tighten.

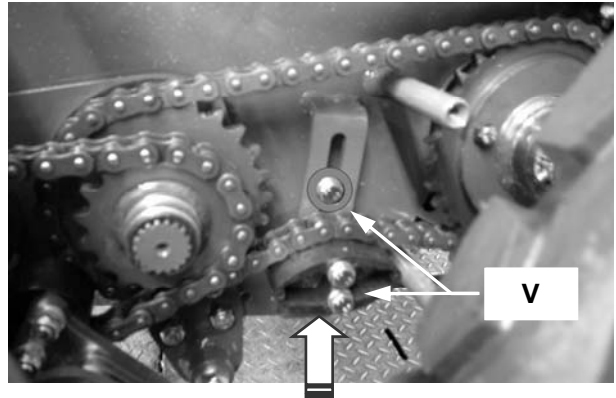

**Transport roller tensioning (right side)**

- Loosen the three screws "V" and, with the help of a hammer, adjust chain tension, moving the tensioner downward with small strokes.
- Once adjusted, re-tighten the three screws "V".

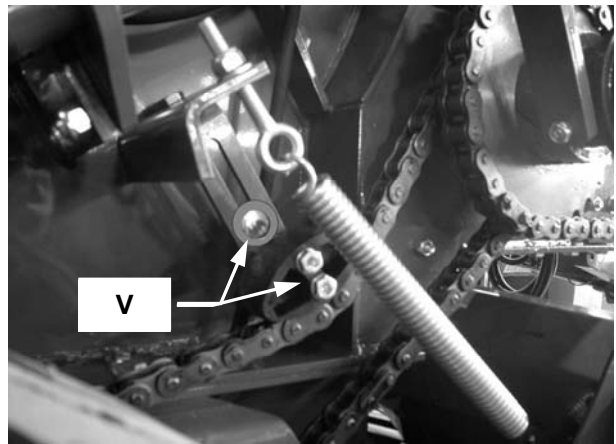

**Tensioning the packer chain (left side)**

1. Loosen screws and remove the safety cover on the left side.
2. Loosen the two screws "V".
3. With the help of a hammer, adjust chain tension, moving the tensioner downward with small strokes.

1



2

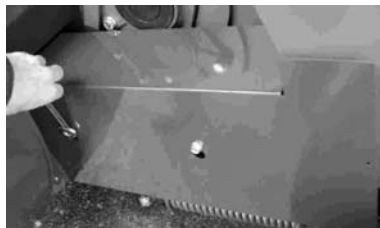

3

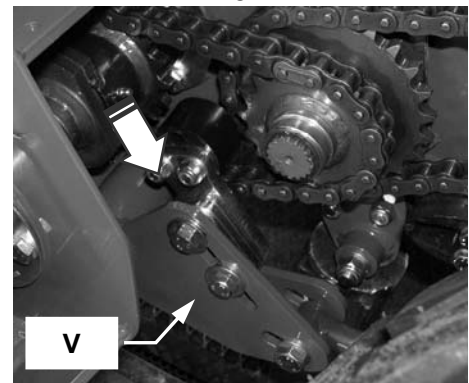

- Once adjusted, re-tighten the two screws "V".
- Replace the safety covers and re-tighten.

**Tensioning the pick-up chain (left side)**

- Loosen screws and remove the safety cover on the left side of the pick-up.
- Loosen the two screws "V" and, with the help of a hammer, adjust chain tension, moving the tensioner upward with small strokes.
- Once adjusted, re-tighten the two screws "V".
- Replace the safety cover and re-tighten.

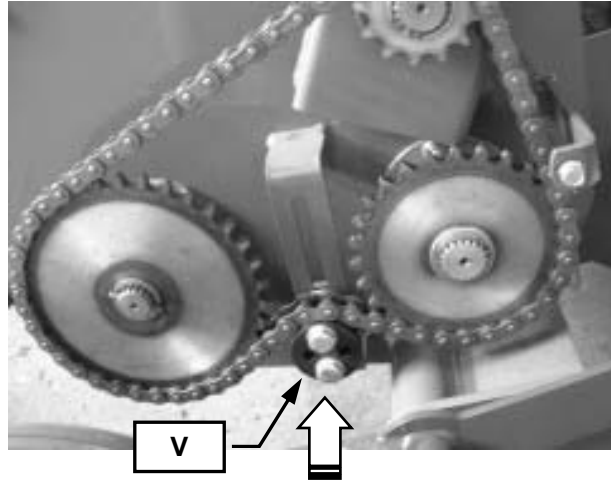

**Tensioning the pick-up chain (right side)**

- Loosen screws and remove the safety cover on the right side of the pick-up.
- Loosen the two screws "V" and, with the help of a hammer, adjust chain tension, moving the tensioner with small strokes.
- Once adjusted, re-tighten the two screws "V".
- Replace the safety cover and re-tighten.

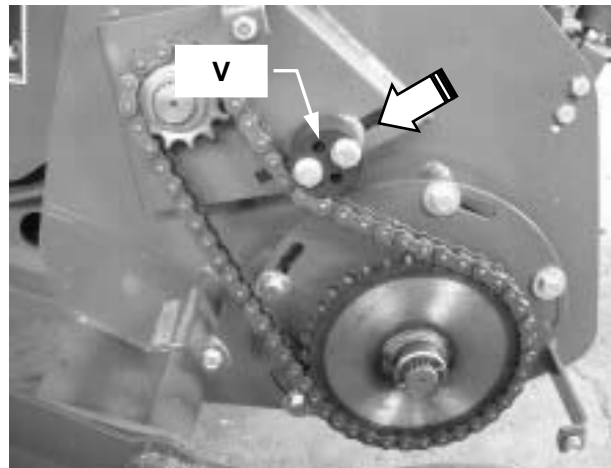

**Catenary**

**IMPORTANT:** Before you perform the regulation, turn on the machine for some minutes. Then, switch off the machine and wait until the stop of all the moving parts.

**IMPORTANT:** With the machine in empty state, adjust the springs that set the tension of the main conveyor chain. The regulation must be the same on both springs (left and right sides of the round baler).

- Screw in the "d" nut.
  - Verify that the distance between the spring guide bushes "A" and "B" is **225 mm**

**IMPORTANT:** Compression must be the same on both left and right springs!

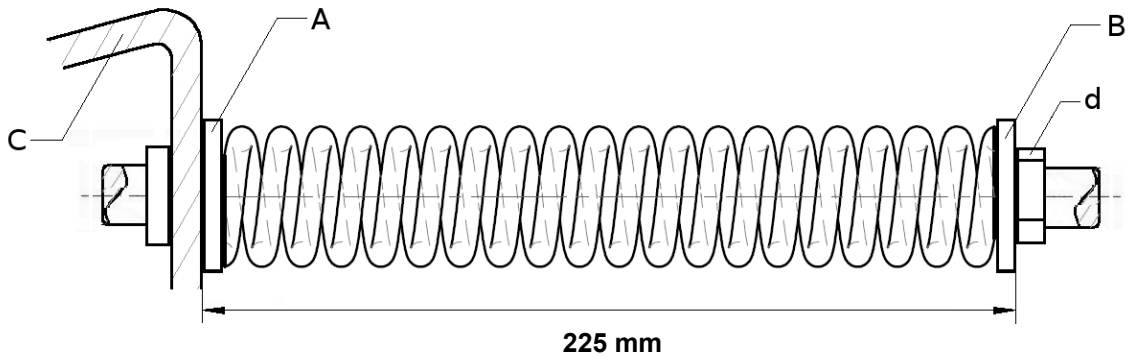
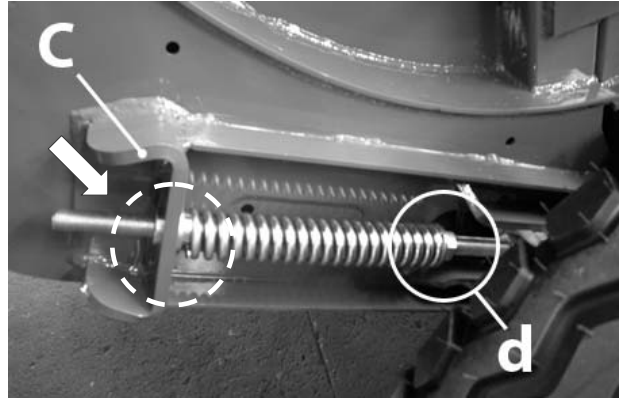

**Release**

Register the catenary release with the hatch open, taking care to leave a span of 5mm (0,2 in) between the connection teeth.

To do this, intervene on the screw "V" placed under the right opening jack of the hatch.

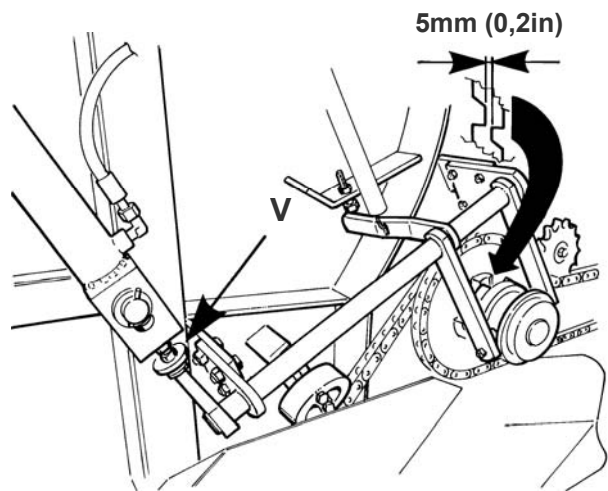

### Replacing the pick-up safety screw

In the event that the bolt on the pick-up safety breaks, replace it with one of the same quality: **bolt "B" TE M8X 45-10.9 UNI5738 – DIN 960** (not galvanised, partially threaded).

- Loosen screws and remove the safety cover on the left side.
- Remove and check if there are any parts of the bolt sheared between transmission components.
- Realign the safety holes, manually turning the auger. Re-insert the bolt and tighten.

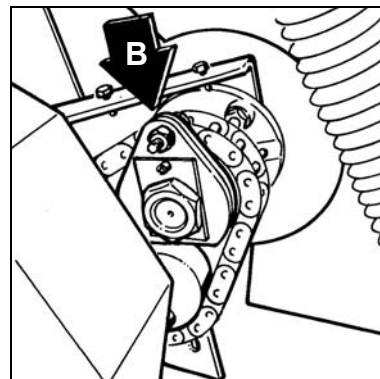
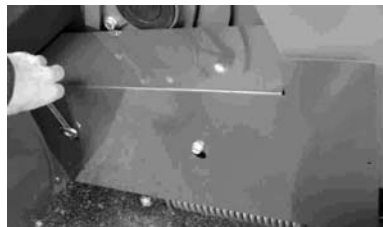

- • Replace the safety covers and re-tighten.

### Replacing the safety screws on the feeding transmission

In the event that the bolts on the feeding transmission safety break, replace them with bolts of the same quality: **bolts "B" TE M8X 40-8.8 UNI5737**.

- Open the right side cover.
- Loosen screws and remove the safety cover on the left side.
- Remove and check if there are any parts of the bolt sheared between transmission components.
- Realign the safety holes, manually turning the gear. Re-insert the bolts and tighten.
- Replace the safety covers and re-tighten.
- Close the right side cover.

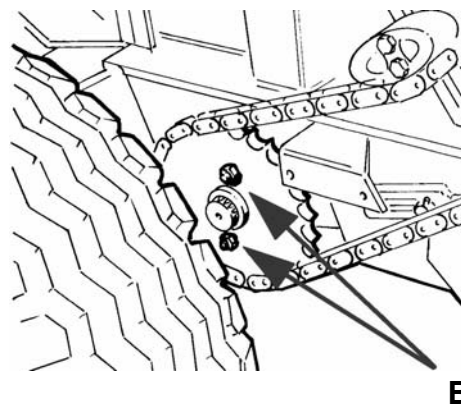

### Replacing collecting teeth

- Loosen the 4 screws "V" (2 on top and 2 below) fastening band "F" near the tooth to be replaced. Then remove the band, passing the head of the screw "V" through the slot hole on the band itself.

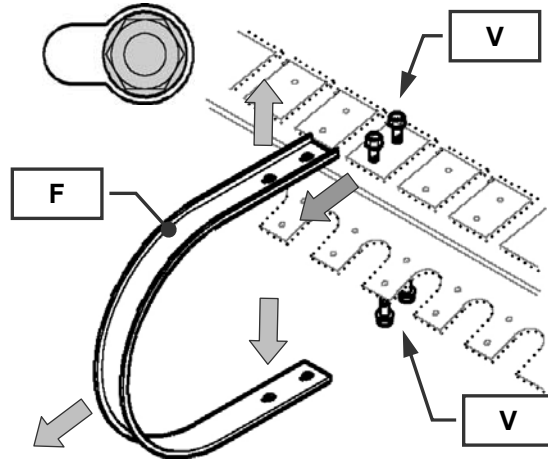

- Unscrew the bolt "B", remove the tooth "D" and its dowel "T".
- Replace the collector tooth "D" with a new one that is the same.
- Retighten with dowel "T" and bolt "B".

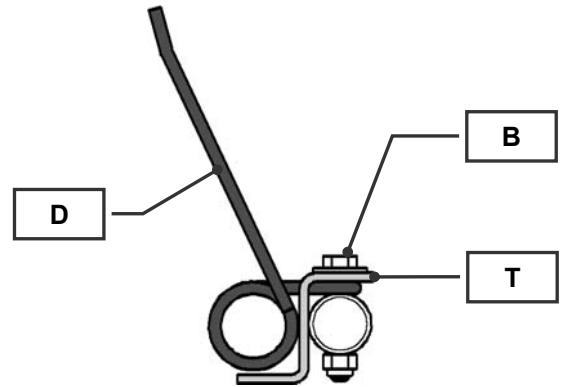

- Replace the band "F", inserting it on screws "V" and push the piece against the screw itself.
- Finally, tighten the 4 screws "V", complying with tightening value 15Nm.

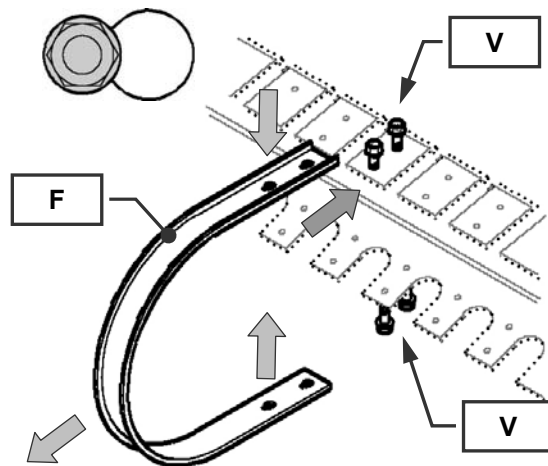

### Adjusting pick-up cams

Adjust the product release position of the collector tooth by intervening on cams located on the right side of the pick-up.

- Loosen screws and remove the safety cover on the right side of the pick-up.
- Loosen the four screws "V" securing the cams.



Adjust cam position, turning it so as to move the collector teeth closer to or away from the transport unit.

#### Turning the cam toward position:

**A = to move tooth closer to the collector unit.**

**B = to move tooth away from the collector unit.**

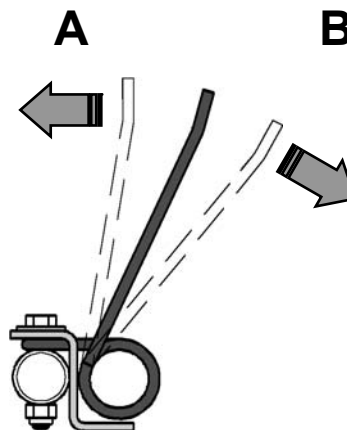
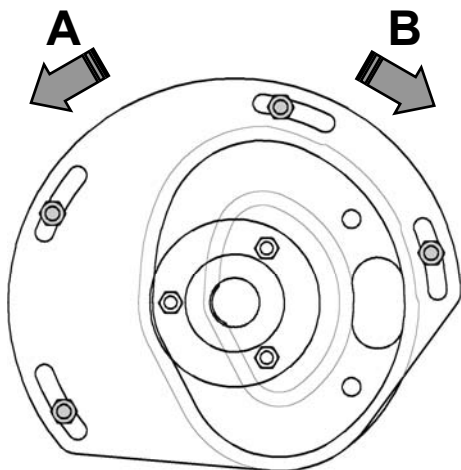

- Once adjusted, re-tighten the two screws "V".
- Replace the safety cover and re-tighten.

**Sharpening the blade**

If twine is not being cut, sharpen the knife blade, only on the cutting edge, as indicated in the figure.

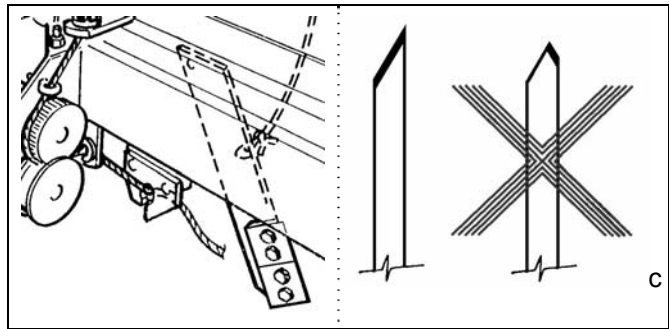

**IMPORTANT: Pay close attention to the binder blade.**

### **Electric and electronic components**

- Check that electrical wires and the control unit are not crushed or damaged.
- Check all outlets, plugs and wiring are clean from any accumulation of earth or product.
- Check and, if necessary, replace bulbs not working in the lighting system.

**IMPORTANT: After the first 200 product bales, check the machine as per the steps described above.**

### **After the first 30 working hours**

**IMPORTANT: Every new machine should be checked after the first 30 hours of operation, taking care to check:**

- **Proper tightening of all nuts and bolts.**
- **Tensioning of all transmission chains.**
- **The absence of oil leaks from any hydraulic system components.**
- **Tyre inflation pressure.**
- **Proper lubrication of transmission components.**
- Comply with recommended lubricants.
- Spare parts must conform to requirements specified by **John Deere**.

### **Daily checks**

**IMPORTANT: Before a new use of the machine, make sure that there are no oil slicks on the ground. In such a case, DO NOT ACTIVATE the machine.**

**Check where there are oil leaks, and only after ascertaining the extent of damage, please contact the authorised service centre.**

- Check the general state of the machine daily: the conditions of wear of crown wheels, supports, bearings, chains, pins, shafts and of all moving and rotating machine parts.

### **Special maintenance**

**IMPORTANT: Contact your Dealer or John Deere Customer Service regarding any failure or malfunction.**

## MACHINE GARAGING / STORAGE

### CAUTION!

Before performing any cleaning operations on the machine, take heed of all basic safety regulations, as contained in chapter "General safety standards".

To avoid injury from unexpected movement, perform maintenance on machines supported firmly on flat, horizontal ground.

Do not perform maintenance while the machine is in movement. Carry out all maintenance operations with the machine switched off and after all moving parts have come to a complete stop:

If the machine is connected to the tractor, engage the tractor parking brake, stop the engine and remove the key. Always switch off the "Electric Control" system.

If the machine is disconnected from the tractor, block the wheels to prevent movement.

Never lift the machine from the ground.

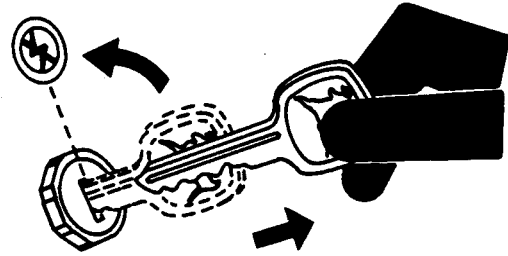

### CAUTION!

If you should need to perform maintenance with the machine hatch open or inside the bale forming chamber, block the hatch using the hatch locking safety device.

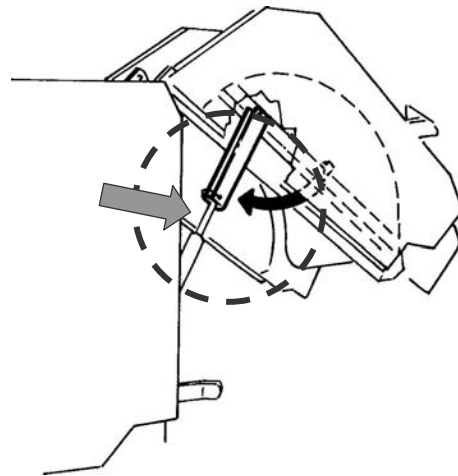

**IMPORTANT:** Equipment will retain its optimal qualities and work can easily be re-started if these operations are performed carefully.

In the event of machine dismantling, abide by the laws regarding pollution and the disposal of lubricants in force in your country.

### Preparing the baler for garaging / Cleaning

Follow the instructions below at the end of a working season, or in the event of a necessary long period of storage:

- Make sure that the machine is completely discharged.
- Discharge pressure from the hydraulic circuit.
- Store the machine in a closed and/or guarded place to prevent access by unauthorised personnel.
- Store the machine in a dry place, protected from the weather and on a suitable and flat surface (to avoid sudden, undesired machine movement, place wedges at wheels).
- Make sure that all guards on the machine are in their correct positions.
- Protect baler with a plastic tarp.
- Remove the net roll and twine reels. Keep them in their boxes in a cool, dry place. Keep them in a box protected from rodents.

**IMPORTANT: Handle twine coils and net rolls with care and without damaging them.**

- Thoroughly clean the outside and inside of the machine.  
Keep the engine transmission clean of any twine, nets or product, in order to avoid damage to bearings and seals.  
Straw and dirt attract moisture, promoting rust.

**IMPORTANT: If you need to use a pressurised jet for cleaning, do not direct pressurised water toward bearings and electrical components.**

**Do not use abrasive products, solvents or alcohol.**

- Never allow the cylinders to come in contact with corrosive chemicals to avoid altering the surface of the piston.  
Grease all exposed parts of cylinder rods and electric actuators to prevent rust.
- Apply some drops of oil on all hinge and joint parts.
- Properly lubricate at all required points. Spread rust protection or oil or grease on all unpainted or unfinished metal parts to protect from rust.  
Grease binder blades.  
Lightly grease threading of all adjustment screws.
- Paint or apply oil on components exhibiting paint wear.
- All gears and chains must be kept clean. Clean chains by washing them with diesel fuel. Dry them thoroughly and lubricate with high viscosity oil.
- Check all outlets, plugs and wiring are clean from any accumulation of earth or product.  
Protect electrical connectors from rust using a suitable fluid.
- Clean the terminal with a damp cloth and using a mild detergent to avoid erasing writing on the panel.  
Remove the control terminal.  
Store them in a place sheltered and protected from the weather, dust, moisture, insects and rodents.
- Remove the cardan shaft from the machine and store in a dry, protected place.  
For further information, read the use and maintenance manual supplied with the shaft itself.
- Perform a thorough check and replace any damaged or worn parts.

**Preparing the baler for the start of a season / Before returning to the field**

Before re-starting field operations, thoroughly verify your machine's conditions and carry out all necessary maintenance operations described in this manual.

- Read this operator's manual again.
- Always follow safety instructions contained in this manual.
- Check and, if necessary, top up the gear box up to the plug level. See section "Lubrication and maintenance."
- Remove oil from chains.
- Fully lubricate the machine to force the exit of moisture from bearings. See section "Lubrication and maintenance."
- Check tyre pressure. See section "Preparing the baler."
- Tighten all screws, nuts and retaining screws. See section "Maintenance."
- Check baler adjustments as described in section "Maintenance".
- Check that the system control monitor is functioning properly.
- Check the areas that will be in contact with the net roll. These areas must be clean and smooth.



## TECHNICAL SPECIFICATIONS

The technical data contained in the tables below is for information purposes, and as such we may update without notice.

The symbol “±” indicates a value ranging from a minimum to a maximum.

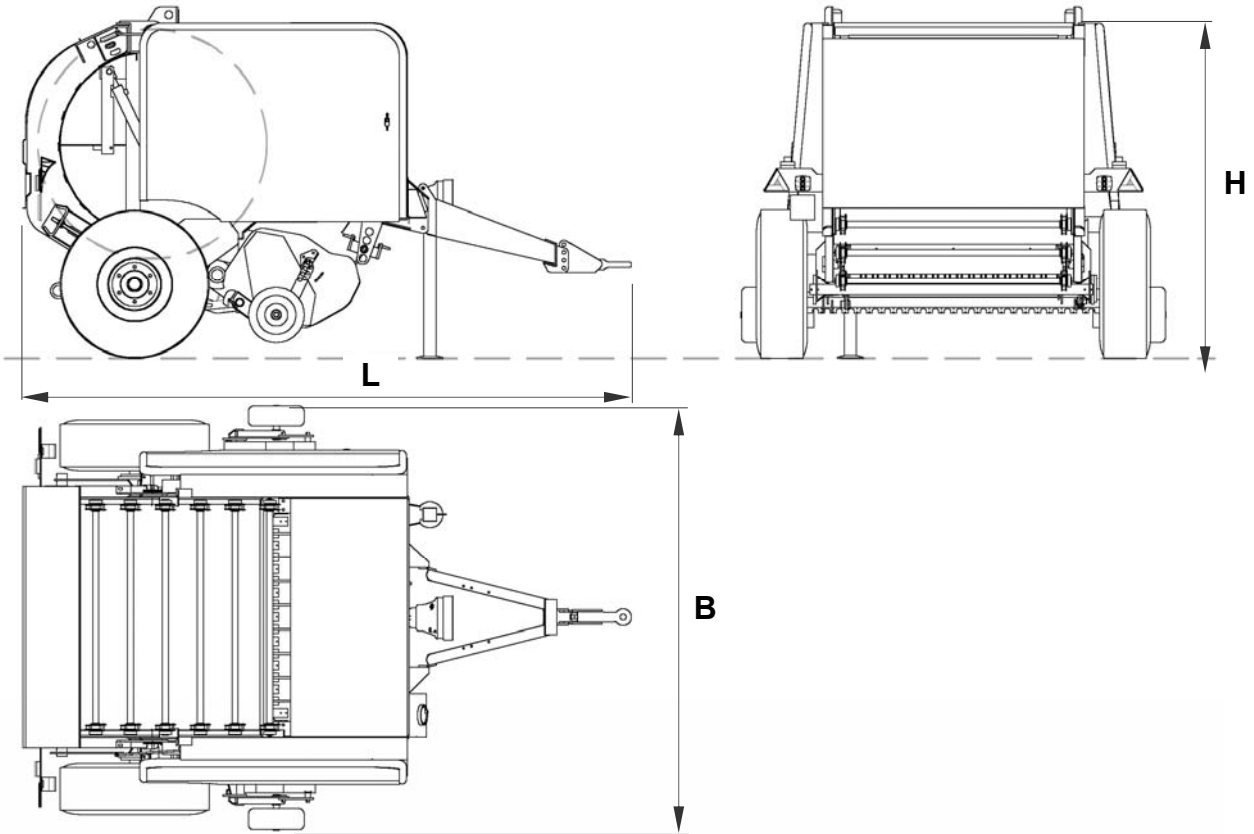

### Baler dimensions

	F440E	F450E
<b>L</b> = Length	3560mm (11ft 8,2in)	3760mm (12ft 4in)
<b>B</b> = Width	2510mm (8ft 2,8in)	2510mm (8ft 2,8in)
<b>H *</b> = Height (with standard tyres)	2020÷2070 mm (6ft 7,5in ÷ 6ft 9,5in)	2320÷2370 mm (7ft 7,3in ÷ 7ft 9,3in)

(\*) The change in height is derived from inverted assembly of the drive shaft.

### Weight

	F440E	F450E
With pick-up	2140kg (4718lb)	2450kg (5401lb)
Load on towing eye (max value)	360kg (794lb)	420kg (926lb)
With bale ejector (optional kit)	2164kg (4771lb)	2474kg (5454lb)

TECHNICAL SPECIFICATIONS

**Pick-up**

Maximum collecting width		1725mm (5ft 7,9in)
Width between teeth		1593mm (5ft 2,7in)
Space between teeth		69 mm (2,7in)
Reel diameter		250 mm (9,8in)
N°. bars per reel		4 mm (0,2in)
N°. teeth per bar		24 mm (0,9in)
N°. total teeth		96 mm (3,8in)
Support wheels		fixed
Wheel size/# canvases		16,650/10
Working height adjustment		mechanical 13 positions

**Transport unit**

N°. teeth	16	16
Space between teeth	69	69 mm (2,7in)

**Binding**

N°. hanks	4	4
Titre of synthetic/vegetable twine (m/kg)	500÷700/200÷400	500÷700/200÷400
Net	standard	standard
Titre of net (g/m)	14÷16	14÷16
Electric remote control	yes	yes

**Bale specifications**

	<b>F440E</b>	<b>F450E</b>
Diameter	1200mm (3ft 11,2in)	1500mm (4ft 11,1in)
Width	1200mm (3ft 11,2in)	1200mm (3ft 11,2in)
Hay bale weight	150÷270 kg (330,7÷595,2 lb)	240÷420 kg (529,1÷925,9 lb)
Straw bale weight	100÷170 kg (220,5÷374,8 lb)	150÷260 kg (330,7÷573,2 lb)
Green bale weight	300÷570 kg (661,4÷1256,6 lb)	480÷900 kg (1058,2÷1984,2 lb)
Hourly production	20÷35	15÷30
Chamber type	fixed	fixed
Bale density	variable	variable
Bale chute/ejector	optional upon request	optional upon request
N°. bars	33	41

TECHNICAL SPECIFICATIONS

**Tractor requirements**

	<b>F440E</b>	<b>F450E</b>
Minimum power kw/cv	30/40	37/50
PTO speed	540 rpm	540 rpm
Hydraulic system	1st double acting outlet + 1st single acting outlet	1st double acting outlet + 1st single acting outlet
Electrical system	7-pole 12V= outlet	7-pole 12V= outlet
Transport speed on road max	40km/h	40km/h
Oil flowrate	25 lt./min	25 lt./min

**Cardan shafts**

	<b>F440E</b>	<b>F450E</b>
Series	5FEF08013080	
Optional	5FEB03600077	

**Tyres**

	<b>F440E</b>	<b>F450E</b>
Series	11.5/80-15.3	11.5/80-15.3
Optional	400/60-15.5	400/60-15.5

**Tyre specifications**

	<b>11.5/80-15.3</b>	<b>400/60-15.5</b>
Canvas quality	12-14 P.R.	10-14 P.R.
Range index (mm)	410	380
Speed (km/h)	40	40
Wheel capacity (kg)	1930÷2187	2240÷2745
Pressure (bar)	3,5	3.5
External diameter (mm)	845	875

**"Electric Control" control system specifications**

Power	10÷30 V Dc
Controls	3x electro-mechanical
Warning light	High efficiency LED
Brightness	~ 46 cd/m <sup>2</sup>
Microprocessor	8 bit
Internal memory	Flash
Acoustic signal	buzzer
Degree of protection	IP 44
Operating temperature	10÷50
Storage temperature	-10÷70
Relative humidity	90% without condensation
Vibration testing (x-y-z for 1hr)	20-50Hz → 1.0G/51-300Hz → 0.5G
Container	ABS
Fastening method	Stainless steel bracket
Overall dimensions (without cable)	120x 96x 68 (L x H x W)
Weight	~ 500g
Conformity	Complies with CE regulations

**Noise level**

Maximum noise level conforms to EN1553

Detection method conforming to ISO3744 (average value) ..... 85 dB(A)

**CE Declaration of conformity**



The company: MASCHIO Fienagione S.p.A.  
Head office: 6, Via Bredina – 26100 Cremona (Italia)

Declares under its own responsibility that the machine: ROLL BALER

Models: F440E and F450E

Complies with the following European Directives:  
The Machinery Directive: 2006/42/CE  
The Electromagnetic Compatibility Directive: 2014/30/CE

The following Harmonised Standards were consulted in order to guarantee the conformity of the machinery:  
EN ISO 4254-11:2010  
EN ISO 4254-1:2015  
CEI EN 60204-1:2013  
EN 15811:2014

As were the following Technical Specifications:  
ISO 11684:1995  
EN ISO 3767-2:2015

Technical File held at:  
MASCHIO Fienagione Technical Department – 6, Via Bredina – Cremona (Italia)

Cremona, 01/08/2016

LEGAL REPRESENTATIVE

A handwritten signature in black ink, appearing to read "M. Gaspardo".

**MASCHIO Fienagione S.p.A. a socio unico**

Sede legale e stabilimento produttivo  
Cremona  
Via Bredina, 6 26100 Cremona (Italy)  
Tel. +39 0372 564610 – Fax +39 0372 564625  
Email: info@maschio.com – www.maschio.com

Capitale sociale euro 1.201.280,00 Sottoscritto e Versato - Cod. Fisc e P.IVA 00106230196 R.E.A. CR n° 44774  
Società sottoposta all'attività di direzione e coordinamento da parte di MASCHIO GASPARDO S.p.a. art. 2497 bis del Codice Civile



## SERIAL / IDENTIFICATION NUMBERS

The serial numbers that identify the baler and accessories are stamped at the factory on special plates.

These numbers and letters are required when ordering baler replacement parts or accessories.

In order to facilitate immediate availability of these numbers, write the corresponding serial numbers in the spaces of each illustration.

### Serial number plate description

- Model/Version
- Serial number
- Machine Weight
- Total allowable weight
- Axle load
- Hitch load
- Year of production
- Type approval Nr.
- Manufactory code

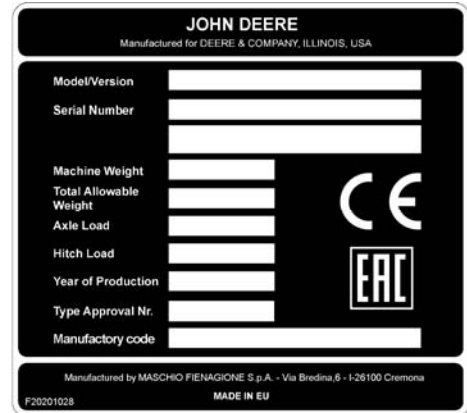

### Baler identification number

The plate with the baler identification number is located on the left side of the tool behind the hinged guard.

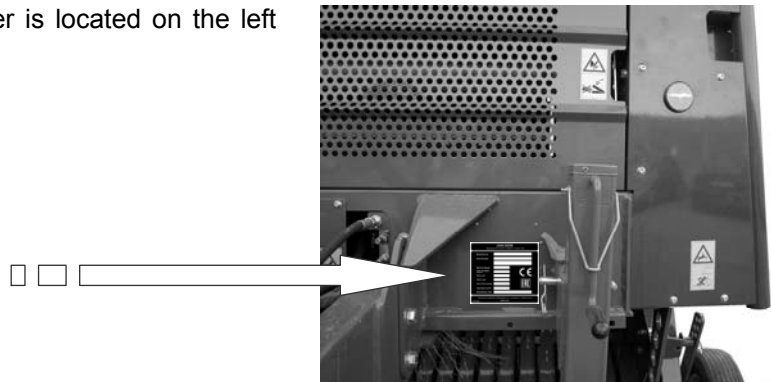

### Security against burglary

- 1 Install anti-vandalism devices.
- 2 When storing the machine:
  - Lower all equipment to the ground.
  - Position the wheels as widely as possible in order to make any locating difficult.
  - Remove keys and batteries.
- 3 If parking the machine in an enclosed space, place a large piece of equipment in front of the exit and lock the building.
- 4 If parking the machine outside, set it in a well-lit and fenced area.
- 5 Be alert of suspicious movements and, in case of theft, immediately file a complaint with the police.

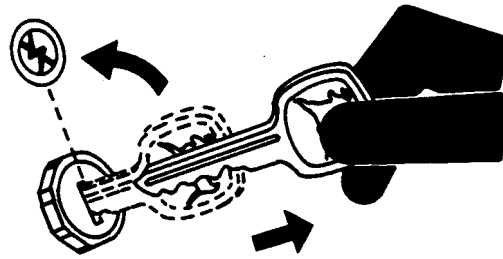

## Our service for your efficiency

### John Deere spare parts

The prompt delivery of original John Deere helps to minimise downtime.

Our large and complete inventory anticipates your needs.



### Suitable tools

Precision tools and testing equipment help our Customer Service to identify and resolve problems quickly, saving you time and money.



### Well-trained technicians

Training is never finished for John Deere service technicians.

To ensure that our staff is familiar with all machines and their maintenance, training courses are held on a regular basis.

The result?

Experience you can count on.



### Quick service

Our goal is to provide fast and efficient service when you need it and where you want.

We can make repairs at your location or in our workshop, depending on circumstances.

**SUPERIOR JOHN DEERE SERVICE:** Always nearby when you need it.



