

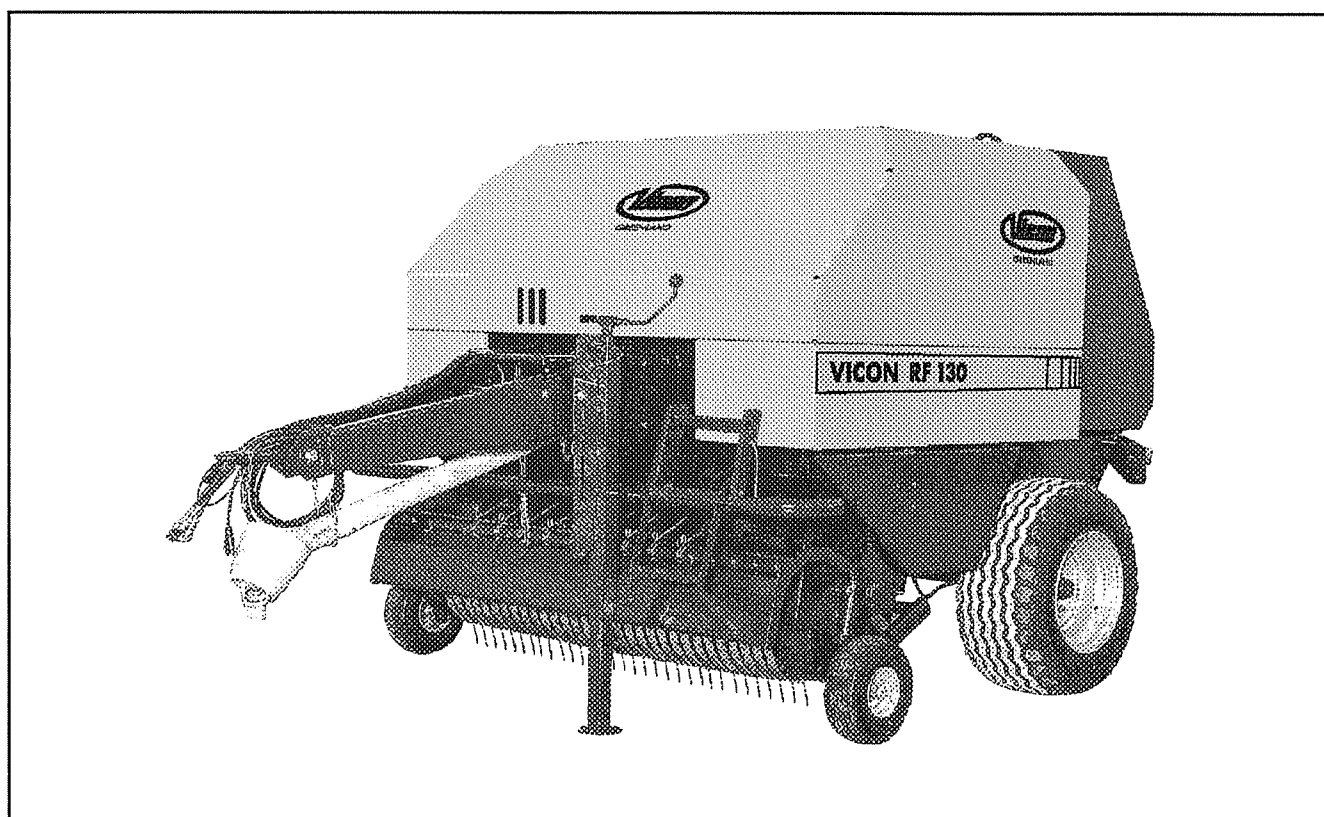

Operation manual

EN

RF 130





EC Declaration of Conformity
as defined by the EC directives

- Machines 89/392/EEC amended by 91/368/EEC and 93/44/EEC, Appendix II
and 93/68/EEC

The machine

product : round baler
type : MP 130 OC / RF 130 OC
identity no. : 6830
serial no. : 14 -
machine no. : 301 -
year of construction : 1997

was solely developed, designed and manufactured, in accordance with the aforementioned EC directives,
by

Kverneland Gottmadingen GmbH & Co. KG
Hauptstraße 99
78244 Gottmadingen
Germany.

The following harmonised norms were applied:

- DIN EN 292/1 and EN 292/2, safety of machines, equipment and systems
- DIN EN 294, safety clearances to danger areas
- DIN EN 982, safety requirements of fluid technology systems and components
- prEN 704 (January 94) safety of agricultural machines - balers
- prEN ISO 14982:1996, electromagnetic compatibility of agricultural and forestry machines

Complete technical documentation is available.

The machine 's operating instructions are available

- in the original version : German
- in the languages : English, French, Dutch, Spanish, Italian, Swedish, Danish

Gottmadingen, 21.03.2002

Rasmus Nordbøe
Managing Director GPA Grass

Foreword

Dear Customer,

We would like to thank you for the trust you are showing in our company in purchasing this Kverneland fixed chamber round baler.

The following operating instructions provide detailed information on starting up and maintaining your new round baler. They also contain safety instructions to ensure risk-free operation. In addition to the equipment and variants that can be supplied, the operating instructions describe all additional equipment not contained in the usual supply schedule. With these operating instructions, we aim to help you get the most out of your Kverneland round baler.

The machine's performance depends to a large extent on it being properly used and carefully maintained. For this reason, the operating instructions should be read through with care before starting up for the first time and should be kept to hand thereafter. By doing this, you will prevent accidents, have the manufacturer's guarantee, and always have a reliable machine that is ready for use.

All information and illustrations in these operating instructions are state-of-the-art at the point in time of publication. Kverneland constantly strives to improve its products. It reserves the right to make all changes and improvements that it considers to be necessary. This does not, however, oblige the company to later modify machines supplied.

If, after reading the operating instructions, you should have further questions, please contact your retailer.

We hope you have a good harvest using your round baler!

Please read and take note of operating instructions and safety regulations prior to start-up.

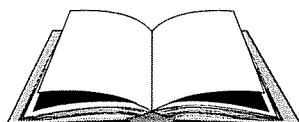

Kverneland Gottmadingen GmbH & Co KG
Hauptstraße 99
78244 Gottmadingen
Germany
Tel.: 073 11-788-0

Fill in your machine details here:

Machine type :

Serial number :

Initial start-up on :

Table of contents

1	Safety	6
1.1	Your personal safety	6
1.2	Safety instructions in this manual	6
1.3	Type plate	7
1.4	Intended use	7
1.5	Liability	7
1.6	Safety stickers and warning signs	8
1.7	Authorised users	12
1.8	General safety and accident prevention regulations	12
1.8.1	General	12
1.8.2	Attached devices	13
1.8.3	Power take-off operation	13
1.8.4	Hydraulic system	14
1.8.5	Tyres and brakes	15
1.9	Safety when not in use and in storage	15
1.10	Maintenance	15
1.11	Safety instructions for round balers	16
2	Technical data	18
2.1	General	18
2.2	Measuring noise	19
3	General description.....	20
3.1	How the round baler functions	20
3.2	Important components of the round baler	21
4	Installation and adjustments.....	22
4.1	Tractor equipment necessary	22
4.2	Mounting the "Autoform"	22
4.3	Adapting the drawbar	23
4.4	Universal drive shaft, coupling	24
4.5	Set baling pressure	25
4.6	Setting pick-up	26
4.6.1	Setting pick-up height	26
4.6.2	Setting pick-up unload	26
4.6.3	Set pick-up baffle plate	27
4.6.4	Pick-up overload protection feature	27
4.7	Setting scrapers	27
4.8	Shearing screws roller drive	27

5	Operation	28
5.1	"Autoform" operation and control unit.....	28
5.2	Pick-up	34
5.3	'Opticut' cutting system	35
	5.3.1 General	35
	5.3.2 Changing the blades	36
	5.3.3 Adjusting the cutting angle	37
5.4	Binding	38
	5.4.1 General	38
	5.4.2 Twine binding	39
	5.4.3 Net wrapping	40
5.5	Tailgate	42
5.6	Reversing mechanism	43
5.7	Hitching to the tractor and road travel	44
5.8	Operation in the field	44
5.10	Winter storage	46
5.9	Storing the Round Baler	46
6	Service and maintenance	47
6.1	Re-tightening screws	47
6.2	Checking wheels	47
6.3	Central chain lubrication device	48
6.4	Chain tightener	48
6.5	Lubrication	49
7	Accessories.....	50
7.1	Cutting system	50
7.2	Filler plates	50
7.3	Bale ramp	50
	7.3.1 Sensor for bale ejection	51
7.4	Additional twine box	51
7.5	Extension cable for "Autoform"	51
7.6	Hydraulic oil filter	51
8	Fault finding	52
A	Appendix	54
A.1	Torque values for international metric thread joints	54
A.2	Hydraulic scheme	55

1 Safety

1.1 Your personal safety

The retailer will have explained to you about operation and maintenance when handing over the machine. Read these operating instructions before using the machine for the first time and be sure to note the safety instructions. Areas of particular importance are marked with a pictograph.



You will find this sign beside all important safety instructions in these operating instructions. Take particular note of these and take extra care when carrying out the operations to which they apply.

The round baler is equipped with protective equipment and its safety and the accident protection it provides have been checked by the *Landwirtschaftliche Berufsgenossenschaft* [Agricultural Professional Association]. However, in the case of maloperation or misuse, a danger is posed to the following:

- the life and limbs of operators, third parties and animals near the machine,
- the machine and other material assets belonging to the operator and third parties,
- the efficient operation of the machine.

All persons concerned with the mounting, start-up, operation and maintenance of the machine must carefully read and take note of the following instructions.

After all, it is your safety that is at issue.

1.2 Safety instructions in this manual

How safety instructions are denoted:



Warning:
This word denotes danger to life or limb. If you see this word in the operating instructions, please take all necessary safety precautions.



Caution:
This word indicates the risk of material damage as well as financial detriment and disadvantage under criminal law (e.g. loss of guarantee rights, liability cases etc.).



Note:
This indicates instructions, application tips and practical information.

1.3 Type plate

The identification plate with machine type and machine number is located on the right hand side at the drawbar linkage point.



Note:

Enter the data on the type plate into the box provided for this purpose on the second page.

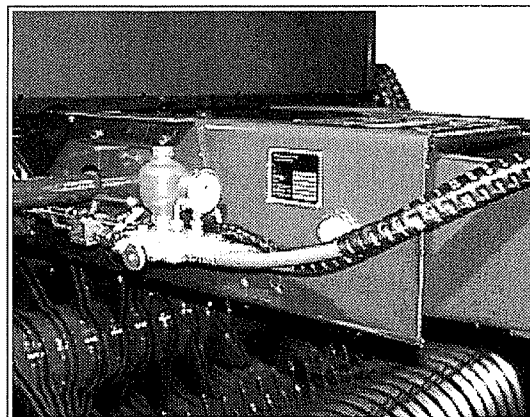

1.4 Intended use

The round baler is exclusively constructed for ordinary use in agricultural work and intended for and suited to gathering mown crops lying in swaths on the ground, compressing this into round bales and binding it with plastic twine or wrapping it with netting.

It is not intended for any other use. The manufacturer shall not be liable for damage resulting therefrom. The user shall bear all responsibility.

Intended use also comprises adhering to the operating, maintenance and servicing directions prescribed by the manufacturer. The machine may only be used, maintained and repaired by persons who are familiar with the work and who have been informed of the dangers.

The relevant accident prevention regulations and other generally recognised regulations concerning safety, industrial medicine and road traffic are to be observed.



Caution:

Unauthorised changes to the machine remove all liability on the manufacturer's part for damage arising therefrom.

1.5 Liability

All persons who work on and with this machine must read and note these operating instructions. Furthermore, this machine may only be deployed for its intended use (see Section 1.4).

1. Work on this machine must be carried out in accordance with the instructions contained in the current documentation.

This documentation can be made up of the following:

- mounting instructions
- operating instructions
- supplementary sheets

2. The following rules and regulations must be observed:
 - the locally applicable, relevant accident prevention regulations,
 - the recognised road traffic, safety and industrial medicine regulations,
 - the functional limits and safety regulations listed in the technical instructions.
3. Only suitable and perfectly functioning tools and equipment may be used in carrying out work on the machine.
4. Only parts (replacement parts, additional equipment, lubricants etc.) may be used that at least correspond to the requirements laid down by the machine manufacturer, and these parts must be used in accordance with the regulations (including the starting torques mentioned).

A part corresponds to requirements when it is an original part or if it has been expressly approved by the machine manufacturer.
5. Unauthorised changes to the machine remove all liability from the manufacturer for damage arising therefrom.



Caution:

Any person not observing the above regulations shall be deemed to be acting in a grossly negligent manner. The manufacturer shall bear no liability for damages arising therefrom. The risk shall be borne entirely by the user.

1.6 Safety stickers and warning signs



Caution:

Real safety means being familiar with all safety stickers. This concerns the type and place of danger and, in particular, the safety measures to be taken. Remain constantly vigilant and be aware of the dangers.

Warning signs are provided on this machine (safety stickers). The stickers together with their explanations are listed in the following and shown on the overall diagram:

1. Before putting the machine into operation, read and understand the operator's manual and the safety precautions and follow all instructions given.

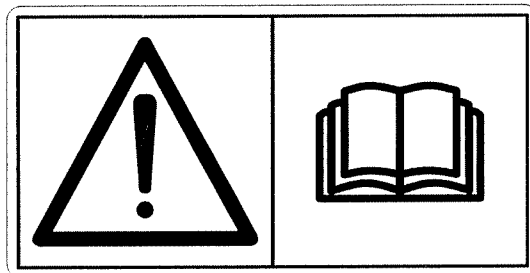

2. Before performing any service and repair work, stop the engine and remove the ignition key.

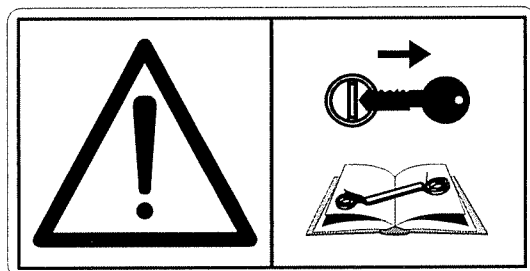

3. Never open or remove protective devices when the engine is running.

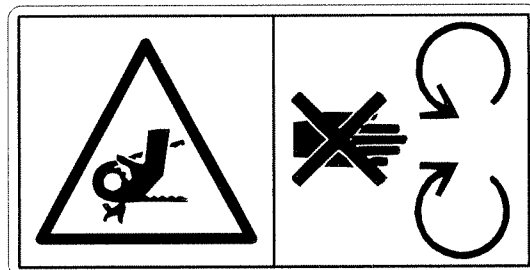

4. Close all protective devices before putting the machine into operation.

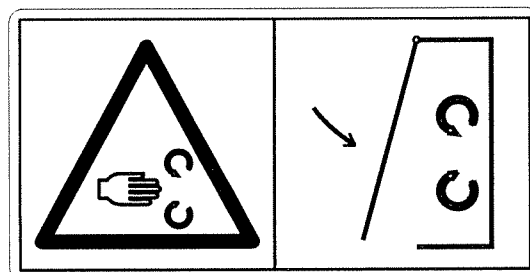

5. During operation stand clear of the danger area of the tailgate.

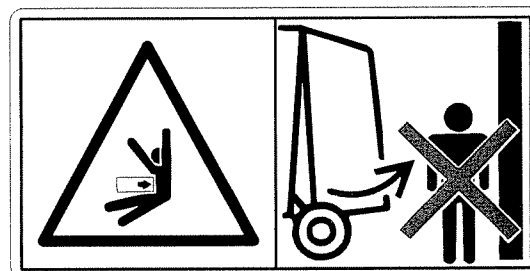

6. During operation stand clear of the danger area.

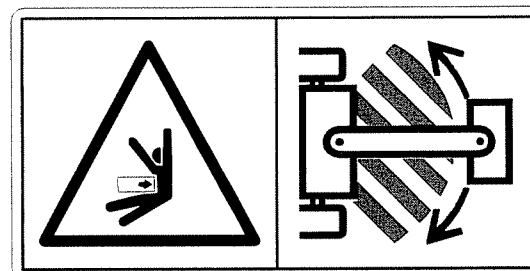

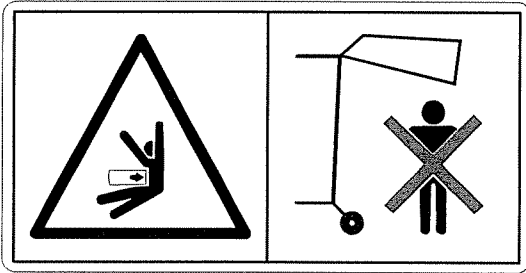

7. Stand clear of the raised tailgate if same is not locked against lowering.

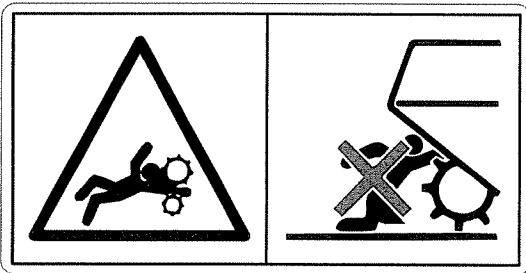

8. Keep hands clear of the pick-up area when the tractor engine is running and the pto shaft is connected.

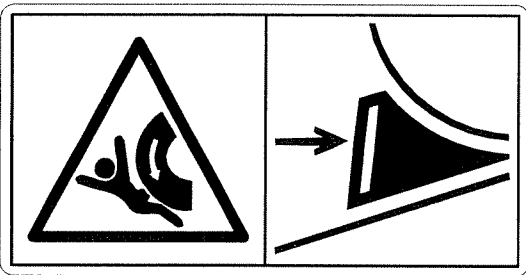

9. Secure the machine by wheel chocks to ensure it cannot move away when uncoupled or stored.

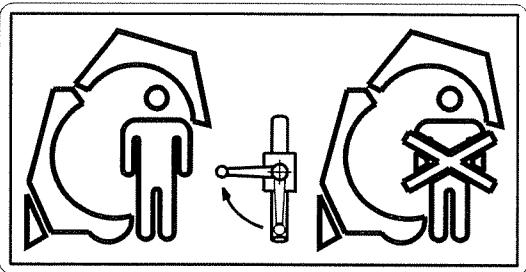

10. Before performing any work under the tailgate or in the bale chamber, close the hydraulic shut-off tap to lock the tailgate. (the hydraulic stop-cock is on the right at the front on the machine, behind the hydraulic block).

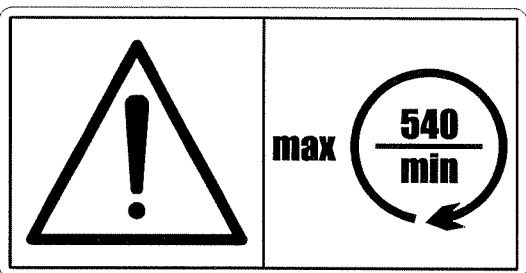

11. Never exceed the prescribed pto speed $n_{\max} = 540$ rpm.

12.



(D) Achtung. Lebensgefahr! Jegliche Tätigkeit an der Bindung nur bei abgestellter Maschine.

(GB) Warning! Danger to life! Stop the machine before carrying out any work on the binding mechanism.

(NL) Let Operation levensgevaarlijk Bij handeling aan de binding machine stop zetten!

(F) Attention! Danger de mort! N'effectuer des travaux sur le mécanisme de liage qu'après avoir arrêté la machine.

(I) Attenzione! Pericolo di vital Prima di effettuare lavori sul meccanismo di legatura arrestare la macchina.

(E) ¡Cuidado! ¡Peligro de muerte! Parar la máquina antes de realizar trabajos en el mecanismo de atado.

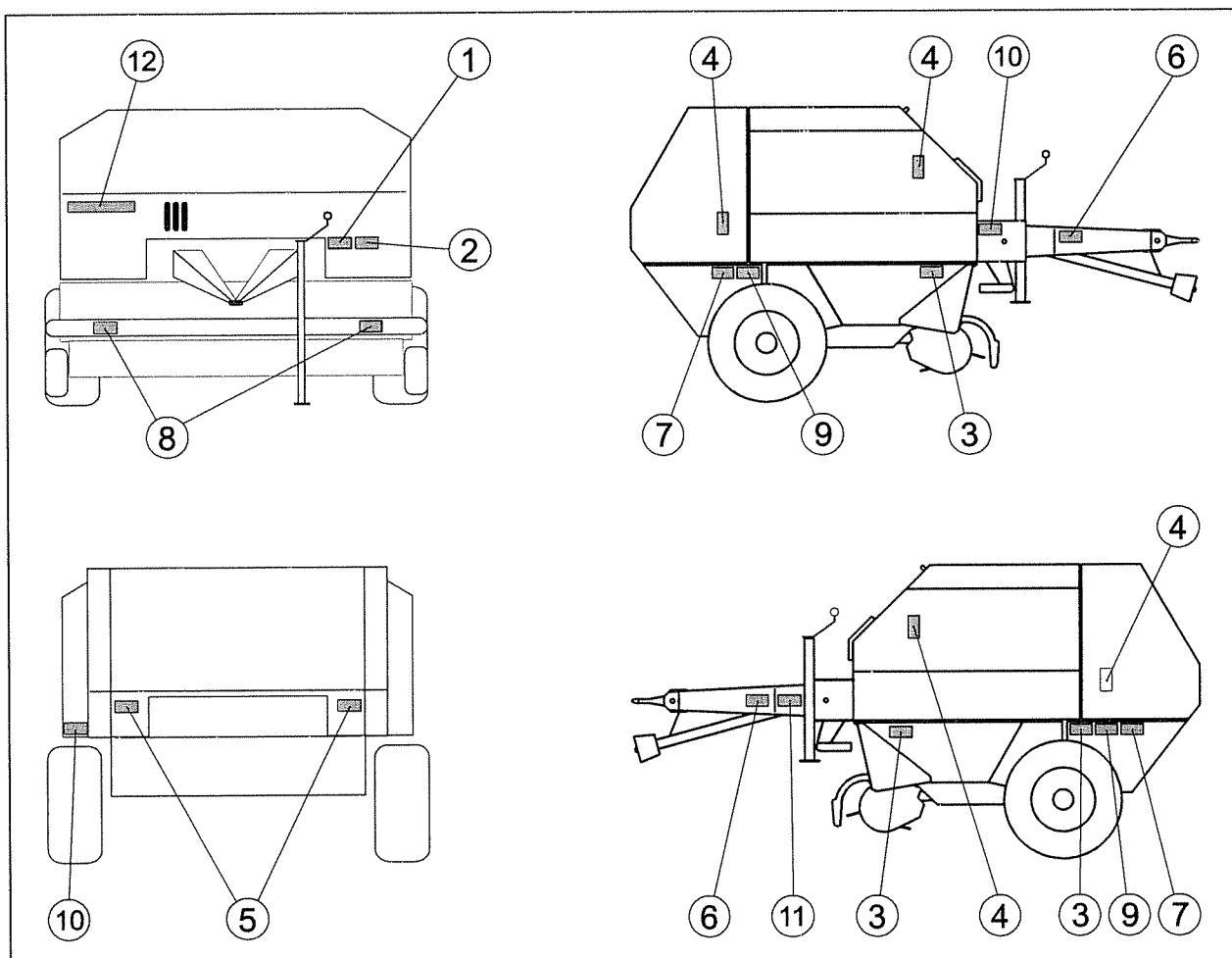

1.7 Authorised users

Youths under 16 years of age may not operate the round baler.

The owner of the machine must make the operating instructions available to the user and ensure that the latter has read and understood same. Only then may the user operate the machine.

The delegation of responsibility for various machine duties must be clearly established and adhered to. There must be no doubt regarding the user's competence as this could put the user at risk.

The owner must ensure that only authorised persons work on the machine. He is responsible for third parties for the area in which the round baler is being used.

1.8 General safety and accident prevention regulations

Basic rule:

Check that the device and tractor are road worthy and operationally safe before each start-up. Note the generally applicable safety and accident prevention regulations as well as the instructions in these operating instructions.

1.8.1 General

1. The warning and notice signs posted provide important information for risk-free operation. Please note these instructions for your own safety.
2. Make yourself familiar with all equipment, operating elements and their functions prior to commencing work. Ensure that all protective devices are properly attached.
3. The user's clothing must fit closely. Do not wear baggy clothes. Wear sturdy shoes.
4. Keep the machine clean. Be aware of the risk of fire.
5. When using public thoroughfares, please observe the following:
 - the statutory road traffic regulations,
 - the permissible axle loads and total weights,
 - the permissible transport dimensions.
 - Never leave the operator's platform while travelling.
6. The equipment must be in the condition prescribed for road transport and be locked according to the manufacturer's instructions.
7. Check and secure transport equipment and the lighting, warning and protective equipment.
8. Operating devices (ropes, chains and linkage) of remote controlled equipment must be installed in such a way that they can not trigger unintentional movements in any transport and working position.
9. Couple equipment according to regulations, and attach and secure to the prescribed devices. Particular care should be taken when coupling and decoupling equipment to or from the tractor.

10. When attaching or detaching, bring the support devices into the position necessary. Be conscious of its stability.
11. Never run the engine in an enclosed area.
12. Check the surrounding area (children) before driving away and starting up. Ensure that you have adequate visibility.
13. Passengers may not be carried on the equipment while on a transport journey. No work may be carried out on the device while in operation.
14. Always adjust travelling speed to suit weather and terrain conditions. Avoid taking sudden curves on inclines and declines and transverse travel on an incline.
15. Attached equipment influences road performance as well as steering and braking. Ensure that you can steer and brake adequately.
16. When taking curves, bear in mind the overhang width and the centrifugal mass of the device.
17. Only operate the device if all protective equipment is in place and in protection position.
18. It is forbidden to remain in the working and danger area.
19. Do not remain in the rotating and swinging range of the device.
20. There are crushing and cutting areas at power-driven parts (e.g. hydraulic parts).
21. Secure equipment before leaving the tractor. Lower the attached implement fully. Switch off the engine and remove the ignition key.
22. No one may remain in the area between the tractor and device if the vehicle is not secured against rolling away by a wheel chock.
23. Note the permissible axle load and total weight as well as the permissible transport dimensions.

1.8.2 Attached devices

1. Secure the device so that it cannot roll away. The wheel blocks are located behind the hinged door on the right hand side of the machine.
2. Take note of the maximum permissible support load of the drawbar coupling, the pending attachment or hitch.
3. Ensure that the drawbar trailer has sufficient mobility at the point of attachment.

1.8.3 Power take-off operation

Applies only to PTO driven equipment.

1. Use only universal drive shafts prescribed by the manufacturer.

Ensure that the universal drive shaft is correctly mounted and secured.

The protective tube and guard cone of the universal drive shaft must be properly attached and be in perfect condition.

Protect guard cone of universal drive shaft from being turned by attaching the chain.

Ensure that the prescribed pipe overlaps are in transport and working position for the universal drive shafts.

2. No one may enter the area of the turning universal drive shaft when working with the universal drive shaft.
3. When using universal drive shafts with an excess load or free-running couplings, overload or free-running couplings are to be attached to the equipment.
4. The universal drive shaft is only to be attached or detached when the PTO shaft and engine have been switched off and the ignition key has been removed.
Place the uncoupled universal drive shaft on the appropriate mount or hang in the chain provided.
After detaching the universal drive shaft, place the protective cover on the PTO shaft end.
5. The PTO guard must be properly attached and be in perfect condition.
Before switching on the PTO shaft, ensure that the rpm selected and rotational direction of the tractor PTO shaft corresponds with the permissible rpm and rotational direction of the device.
Before switching on the PTO shaft, ensure that no one is in the machine's danger area.
6. Never switch the PTO shaft on while the machine is switched off.
7. Always switch off the PTO shaft if the angles of operation are too large or if you do not need it.
8. Only clean, lubricate or set the PTO driven equipment or universal drive shaft when the PTO shaft and engine are switched off and the ignition key has been removed.
9. Any damage is to be repaired before using the machine.

1.8.4 Hydraulic system

1. Warning: The hydraulic system is under high pressure.
2. Check the hydraulic hose pipes regularly and replace them when they are damaged or become old. The replacement hose pipes must correspond to the technical requirements of the equipment manufacturer.
3. Lower equipment and units before commencing work on the hydraulic system. First depressurize the system and then switch off the engine (Pressure gauge display, 0 bar).
4. Use appropriate aids when searching for leaks. Be aware of the risk of injury.
5. The prescribed connection of hydraulic hoses is to be observed when connecting hydraulic cylinders. When connecting the hydraulic hoses to the tractor hydraulic system, ensure that the hydraulic system is depressurized both at the tractor and at the equipment. Only connect up compatible hydraulic fittings!
6. Mark the coupling sleeves and plugs at hydraulic function connections between the tractor and equipment to avoid misconnections. If the connections are mixed up, the functions of the components are reversed (e.g. raising, lowering). Be aware of the risk of accidents.
 - red = open,
 - yellow = close,
 - not marked = pick up
7. Liquids escaping under high pressure (hydraulic oil) can penetrate the skin and cause serious injury. In the case of injury, medical advice is to be sought immediately. Risk of infection.
8. After closing the tailgate and then allowing pressure to build up (control by the pressure gauge on the hydraulic block), the tractor control valve is to be returned to the neutral position.

1.8.5 Tyres and brakes

1. When carrying out work on the tyres, ensure that the machine is safely parked and secured against rolling away. Use the wheel chocks.
2. The mounting of tyres and wheels calls for a sufficient level of knowledge and mounting tools conforming to specifications.
3. Repair work on and the mounting of tyres and wheels may only be carried out by skilled persons using tools suited to the purpose.
4. Check air pressure regularly. Adhere to prescribed air pressure.
5. The wheel nuts are to be tightened after the first 10 operating hours. The torque moment is 325 Nm (M18 x 1.5).
6. Check that the brakes are in proper working order before each journey.
7. The brake system is to be checked on a regular basis.
8. Adjustment and repair work on the brake system may only be carried out by a specialist workshop or a recognised brake service.

1.9 Safety when not in use and in storage

1. Store the device in a safe place.
2. Never allow children to play on or around the device.
3. Never couple or decouple the device on anything but firm, dry and level ground. This reduces the risk of overturning or sinking into soft ground or mud.
4. Lay down the decoupled universal drive shaft on the mount provided.

1.10 Maintenance

Direction signs ('to the right', 'to the left', 'to the front', 'to the back') apply to the direction of travel.

The direction of rotation is defined as follows:

- direction of rotation right = clockwise,
- direction of rotation left = anti-clockwise,
- rotation about a perpendicular axis, viewed from top to bottom,
- rotation about a horizontal axis, at right angles to the direction of travel, viewed from left to right,
- rotation of bolts, nuts and similar, always viewed from the operating side.

1. Repair, maintenance and cleaning work and the elimination of malfunctions may only ever be carried out when the drive mechanism is switched off and the engine is at a standstill. Remove ignition key.
2. Check nuts and bolts regularly to ensure that they are tight and re-tighten if necessary. Keep to the torques given. (See Appendix A.1 for torques for bolt connections).
3. When carrying out maintenance work on the raised device/unit, always secure with suitable supports.
4. When interchanging work tools, use suitable tools and wear gloves.
5. Dispose of oils, grease and filters properly.
6. Always disconnect the current supply before carrying out work on the electrical system.
7. If protective equipment is subject to wear and tear, it is to be checked regularly and replaced in good time.
8. Disconnect cable to generator and battery when carrying out electrical welding work on the tractor and attached devices.

1.11 Safety instructions for round balers

1. This documentation and the UVV [Decree concerning Accident Prevention] 1.1 § 1 of the *Landwirtschaftliche Berufsgenossenschaft* [Agricultural Professional Association] contains general safety instructions.
2. The round baler is to be attached to the tractor before start-up. (Risk of overturning when the tailgate is opened).
3. Never operate the round baler without a protective device.
4. Protect guard tube of universal drive shaft and protecting pot from being turned. Fit the safety chain!
5. Wait for all moving parts to come to a standstill before carrying out any work on the press.
6. Blockages are only to be removed and malfunctions are only to be eliminated when the PTO shaft is switched off and the engine is at a standstill. Remove the ignition key. There is a risk of getting caught in moving parts.
7. Never try to introduce the crop by machine or to remove blockages as long as the press is in operation.
8. Only insert binding material (twine and netting) when the tractor engine is switched off and the ignition key has been removed. There is a risk of getting caught in moving parts.
9. Only thread twine and netting and eliminate malfunctions when the tractor engine is switched off and the ignition key has been removed.
10. When moving the support device, beware of crushing and cutting areas.
11. No one may be in front of the pick-up while the press is running. There is a risk of getting caught in moving parts.
12. No one may be behind the machine while bales are being ejected.
13. While in operation, keep at a sufficient safety distance from the feed elements such as the pick-up, intake auger etc.: due to their function, the feed elements cannot be fully covered.

14. Only eliminate malfunctions of feed elements such as the pick-up, intake auger, conveying roller etc. when the tractor engine has been switched off and the ignition key has been removed.
15. The permissible speed limit is to be observed when transporting on roads.
16. Repairs to prestressed energy accumulators (springs etc.) call for sufficient knowledge and mounting tools that conform to specifications and may only be carried out in specialist workshops. Hydraulic accumulators may not be repaired!
17. To avoid the risk of fire, it is recommended to carry a 12 kg fire extinguisher.
18. When working on hilly terrain, lay round bales face down on the slope incline so that they can not roll away.
19. Do not try to stop a round bale rolling down a slope. Be aware of the risk of injury.
20. Take particular care when opening and closing the tailgate. Persons may not enter the swinging range of the gate.
21. Before entering the bale chamber, the tailgate supports must be brought into safety position and the shut-off tap in the hydraulic supply tube must be shut.
22. Whenever work is being carried out on or around the beating arm/net wrapping, the cutting device must not be live.

2 Technical data

2.1 General

		Standard	Option
Dimensions, weight			
length / mm	4170		
width /mm	2470		
height / mm	2210		
weight / kg	2550 (standard equipment)		
Operating / lighting			
Necessary control units on the tractor side	1 single/ 1 double-acting control unit		
controlbox "AUTOFORM"	three-pin DIN 9680, with cable isolating point	x	
	cable extension 1,5 m		x
Current supply - lighting:	seven-pin; in accordance with STVZO (Federal Motor Vehicle Safety Standards)	x	
Hitching			
ring hitch	40 mm	x	
ring hitch rotatable	40 mm		x
hitch eye: fixed	52 mm		x
hitch	33 mm		x
Drive mechanism			
central gear	540 min ⁻¹		
univ. drive shaft/WWE	with pin clutch 1800 Nm		
rolling chamber	front / rear part parallel driven		
Rotor reversal	mechanical		
Pick Up			
working width / in mm	2100	x	
Number of tine rows	5	x	
Lift	hydraulic	x	
Compensation springs	adjustable 4 ways	x	
Feeler wheel - pneumatic	adjustable 2 x 6 ways	x	
Baffle plate		x	
Overload protection feature	shear bolt M8 x 45 8.8 DIN 931	x	
OptiCut cutting system			
Number of cutting points	14	x	
Knife distance - in mm	70	x	
Blade filling plates	14		x

		Standard	Option
Rolling chamber			
bale diameter / mm	1250	x	
Rolling chamber width - mm	1220	x	
Number of ripped rollers	18	x	
Roller diameter - mm	190	x	
Rolling chamber lock	hydraulic	x	
Bale density adjustment	hydraulic	x	
Bale ramp			x
Bale ramp sensor			x
Chain lubrication	automatically	x	
Overload protection - rollers	2 x shear bolt M8 x 45 DIN 931 10.9	x	
Binding			
Activation	manual / automatic	x	
Twine binding		x	
Net wrapping			x
Twine + Net			x
Binding material supply			
Twine binding	6 rolls of twine	x	
Net wrapping	2 rolls of netting	x	
Twine binding + Net wrapping	1 roll of netting + 6 rolls of twine or 2 rolls of netting or 6 + 4 rolls of twine	x	
Twine box / additional	for 6 more rolls of twine		x
Axles			
Wheel axle	25 km/h	x	
Wheel axle with parking brake	25 km/h		x
Brake axle pneumatic	40 km/h		x
Brake axle hydraulic	25 km/h		x

2.2 Measuring noise

The emission sound pressure level was measured in accordance with EN 31 201 and EN 31 204.

A-weighted equivalent sound pressure level

	Tractor	Tractor and baler
Cabin window open	76,7 dB(A)	83,7 dB(A)
Cabin window closed	74,2 dB(A)	75,2dB(A)

Acoustic capacity level and acoustic capacity

	Tractor	Tractor and baler
Acoustic capacity level	106,1 dB(A)	115,2 dB(A)
Acoustic capacity	40,3 mW	371 mW

3 General description

3.1 How the round baler functions

The functions of the round baler are controlled via the "Autoform" (1) installed in the tractor cab in conjunction with a single and double-acting control unit. The hydraulically controlled functions and binding options are preselected using the "Autoform". The display indicates the user's requests, the number of bales and malfunctions.

The round baler compacts green matter, hay and straw lying in swaths into round bales. The baling material is taken up by the pick-up (8) and the pressure of the baffle plate feeds it to the conveyor channel. The two exterior augers bring wide swaths together to the width of the bale chamber. The conveyor drum is equipped with spirally configured double tines and guarantees continuous filling of the bale chamber. When equipped with the 'OptiCut' cutting system and moved in blades (9), the baling material is directed over the 14 blades and cut. Each blade has foreign body protection and automatically moves back into cutting position once a foreign body has passed. Compression into firm, dimensionally stable bales occurs in the baling chamber.

Baling pressure can be preselected in accordance with the conditions of use and compression requirements. Baling pressure is regulated hydraulically by means of a control valve (hand wheel). The baling pressure set can be read on a manometer. An audible signal notifies the driver once baling pressure reaches 90%. In addition to the audible signal, the notice 'STOP' is given on the display once 100% is reached. The machine is then to be stopped. Depending on the choice, binding can be started automatically or manually. Twine binding (15) and net wrapping (16) are the binding options available, depending on the type of equipment. Once the binding process is over, the driver opens the tailgate hydraulically and the bale rolls out of the baling chamber. With the optionally available bale run (11), bales are dropped gently in the area outside the tailgate. The tailgate is then closed. The notice 'START' appears on the display and the baling process can begin again.

3.2 Important components of the round baler

- 1 "Autoform"
- 2 Hydraulic cables - 1 single-acting control unit - 1 double-acting control unit
- 3 Drawbar with ring hitch, precisely adjustable
- 4 WWE wide-angle universal drive shaft with wedge clutch (on device)
- 5 Stand, pivoted with adjustable crank
- 6 Manometer for bale density
- 7 Pick-up - feeler wheel, pneumatic, height adjustable 2 x 6 ways
- 8 Pick-up with baffle plate
- 9 OptiCut device
- 10 Wheel, brake depending on equipment
- 11 Bale ramp, optional
- 12 Tailgate - hydraulic cylinder
- 13 Ripped bale forming roller
- 14 Lift eyes
- 15 Twine binding device
- 16 Net binding device
- 17 Front hood
- 18 Box for twine / second net roll
- 19 Box for net roll

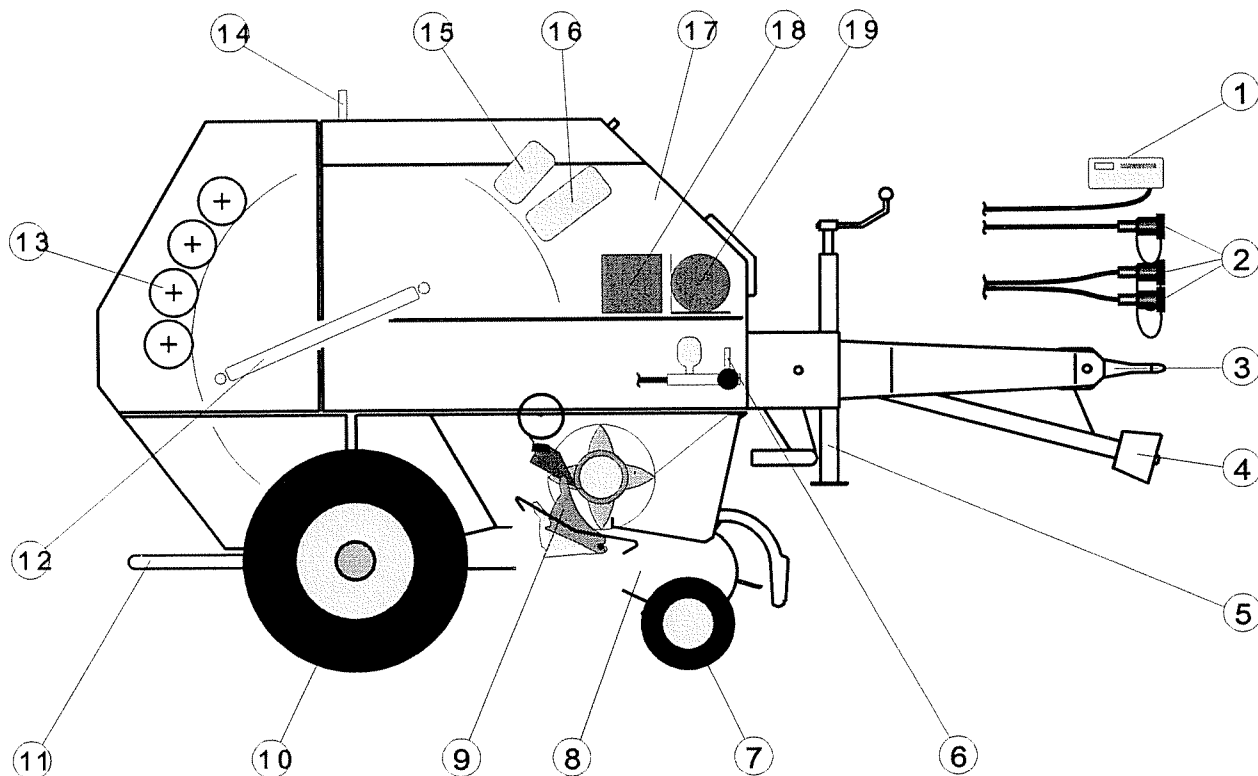

4 Installation and adjustments

Caution:



Adjusting, maintenance and repair work is only to be carried out when the motor is switched off and the machine is at a standstill. Remove ignition key.

4.1 Tractor equipment necessary

The necessary PTO shaft speed to operate the round baler is 540 rpm.

The PTO shaft must guarantee operation independent of the tractor coupling.

To control the hydraulic functions, the round baler requires:

- a single-acting control unit (one remote connection)
- a double-acting control unit (two remote connections)

Caution



First connect the hydraulic line with the yellow marking. Then place the control unit to "lower" (close the tailgate) and check the pressure on the pressure gauge. Then and only then connect the hydraulic line with the red marking.

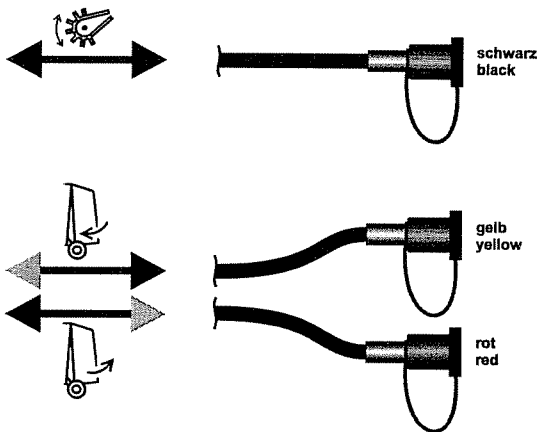
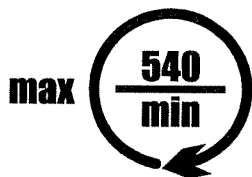

A three-pin socket that meets the DIN 9680 specifications must be provided on the tractor for current supply to the "Autoform". The current supply for lighting is drawn from a seven-pin plug.

When using the optionally available pneumatic/hydraulic 40 km/h brake axles, the appropriate tractor connections are necessary.

4.2. Mounting the "Autoform"

To mount the "Autoform", the clamp clip (a) is mounted in a clearly visible position on the safety frame/roll bar or on the centre bar of the tractor cab. The mount (b) is screwed to the clamp clip and forms the receptacle for the "Autoform".

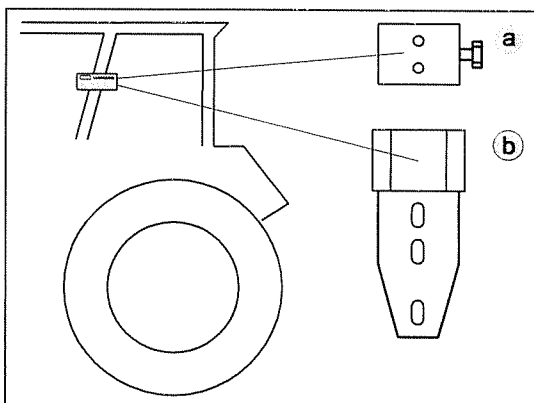

When the machine is disconnected, the "Autoform" can remain in the tractor cab. The cable plug (bolt connection) is to be separated at the box housing.

If not in use the control box can be attached to a special support on the left hand drawbar side, next to the front panel.

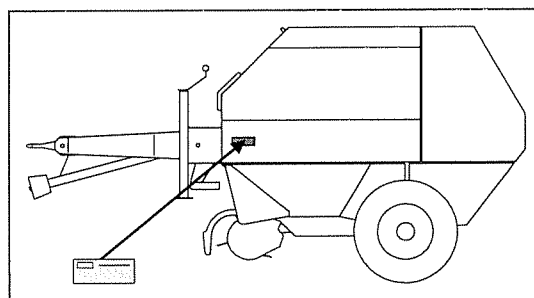

Note:

The "Autoform" must be protected against damp!

4.3 Adapting the drawbar

The drawbar is to be adjusted in such a way that the baler is horizontal when hooked up, when the vehicle is equipped with standard tyres. When the vehicle is equipped with 500-tyres, the baler must be slanting approx. 2° to the front to achieve optimum material flow. The drawbar height is set by loosening the fastening bolt and adjusting the toothed disks. A hitching height of a minimum of 193 mm and a maximum of 1159 mm is possible.

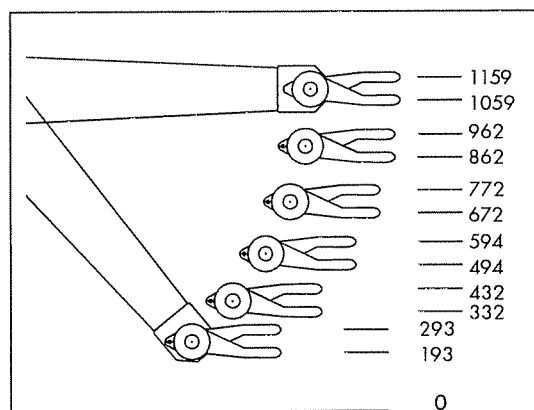

Caution:

When adjusting the drawbar, prevent the baler from rolling away by placing chocks in front of it.

Adjusting:

- Bring the round baler into horizontal position using the support wheel - adjustable crank. Orientate towards the protective cover.
- Loosen the right and left drawbar fastening bolts (on the device) and tilt the drawbar to hitch height (centre of the ring-hitch fastening bolt to centre of drawbar coupling/upper edge of pending attachment)
- The ring hitch is to be brought into horizontal position by loosening the ring-hitch fastening bolt.
- Ensure that the three fastening bolts are tight = 1000 Nm (see Appendix A.1 for torque moment of bolt connections)

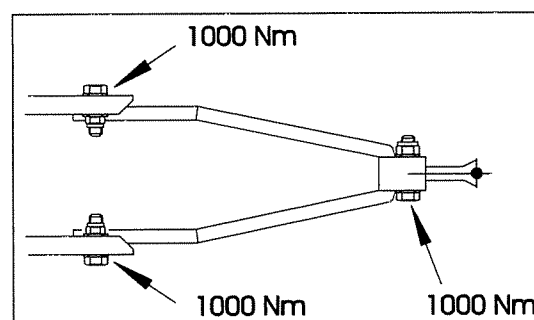

4.4 Universal drive shaft, coupling

A WWE wide-angle universal drive shaft with integrated wedge clutch is supplied with the round baler. If the baler is overloaded, it switches the driving torque to 'zero'. This breaks the power flux and the machine stops. Coupling takes place automatically at a PTO speed of under 200 rpm.

Torques of $1800 \text{ Nm} \pm 10\%$ (for a PTO speed of 540 rpm) are preset by the universal drive shaft manufacturer.

Interference of any kind to the coupling mechanism shall nullify all guarantees for damage caused by such interference.

The protecting pot (on the device) has mounting openings so that the universal drive shaft can be pushed onto the central-gear drive shaft and clamped down. The torque moment of the bolts is 85 Nm. Both mounting openings are then to be properly closed with the covers.

It is sometimes necessary to correct the length of the universal drive shaft due to the different hitching possibilities and various tractor types.

To check and correct the length, proceed as follows:

- hitch the round baler to the tractor,
- drawbar must be set as described in Section 4.3,
- pull apart the universal drive shaft and mount the halves to the tractor and machine,
- hold the universal drive shaft halves under each other,
- when taking all curves and when driving straight, ensure that:
 - a minimum overlap of $b = 200 \text{ mm}$ is guaranteed,
 - the universal drive shaft is not sitting on the block, minimum distance $a = 20 \text{ mm}$,
 - there is sufficient clearance between the drawbar and the universal drive shaft.
- if it is necessary to shorten the length, saw the same amount off both the sliding and protective tubes.
- carefully burr the pipe ends, remove shavings and grease sliding points well.

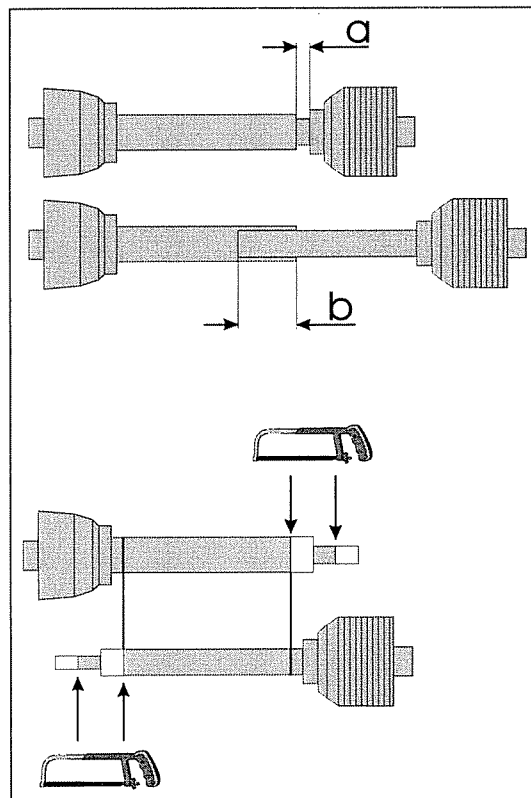

4.5 Set baling pressure

The bale density of a round bale depends on the quality of the crop and the set baling pressure. Baling pressure is regulated hydraulically. By turning the adjusting wheel of the control valve to the right, the baling pressure is increased, and the baling pressure is reduced. Pressure can be set to a maximum of 170 bar. (The system design means that a pressure loss of approx. 10% is possible because of thermodynamic processes in the accumulator)

When making the basic setting, proceed as follows:

- set the control valve for the tailgate to 'lower' while the tractor is running
- the preset pressure set can be read off the manometer on the press
- by turning the adjusting wheel, the baling pressure can now be set and be directly read off the manometer. It is easier to turn the adjusting wheel when the system is not under pressure.

Start adjustment at low pressure level (knurled screw unscrewed). No direct pressure display possible during re-adjustment.

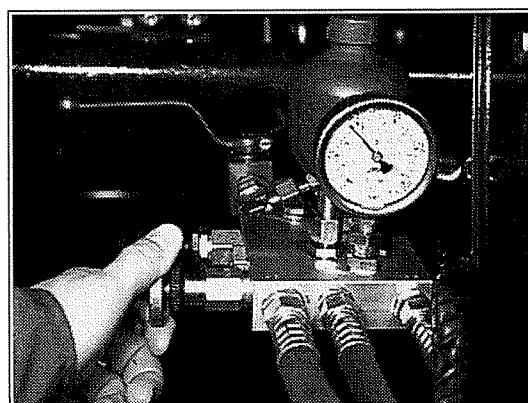

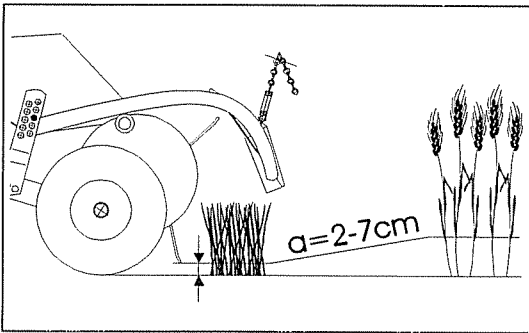

4.6 Setting pick-up

4.6.1 Setting pick-up height

The pick-up is raised and lowered hydraulically using the tractor control unit. To do this, the 'pick-up' function must be preselected at the "Autoform" (LED on).

The working height of pick-up is set using two feeler wheels (right and left).

The height at which material is lifted up cleanly is to be set in accordance with the ground conditions and the quality of the baling material.

The distance between the tine tips at their lowest position and the ground is the decisive factor. Indicative values here are a minimum clearance of $a=2$ cm for green crops and hay, or a maximum clearance of $a=7$ cm for straw. The tines should not come into contact with the ground to prevent the baling material becoming dirty and above-average wear of the tines.

The distance between the tines and ground is set using 2 x 6 borings at the feeler wheel rod (b). Ensure that the setting at the right and left feeler wheels is the same.

4.6.2 Setting pick-up unload

The ground pressure of the pick-up above the feeler wheels can be set using the right and left compensation spring (a). The springs are pushed by the hydraulic cylinder of the pick-up lift. Unload can be preset by selectively inserting the sliding clips (b) into one of the four positions.

Stronger unloading (foremost groove in direction of travel) for soft ground or gentler unloading (furthest groove back in direction of travel) for hard ground and 'jump' for pick-up when the ground is not level.

To insert the sliding clips into different grooves, the pick-up must be raised to the limit.

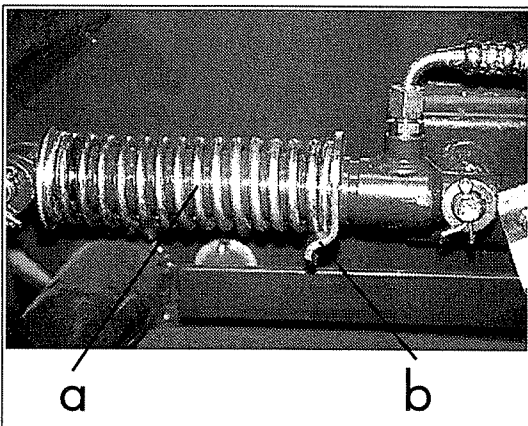

4.6.3 Set pick-up baffle plate

The function of the baffle plate is to hold down the baling material in order to achieve an even flow of material. The height of the baffle plate can be adjusted using two chains to suit the type of material and its volume.

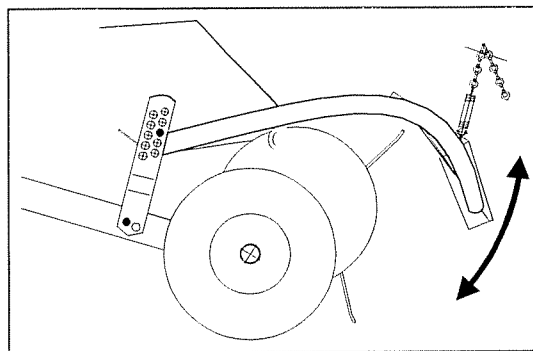

4.6.4 Pick-up overload protection feature

In order to prevent damage, the pick-up is equipped with a torque protector in the drive mechanism. When there is overloading, the power flux is interrupted by the breaking of shear bolt M8 x 45 8.8 DIN 931 (a) and pick-up stops. When shear bolts are being changed, only top quality bolts are to be used.

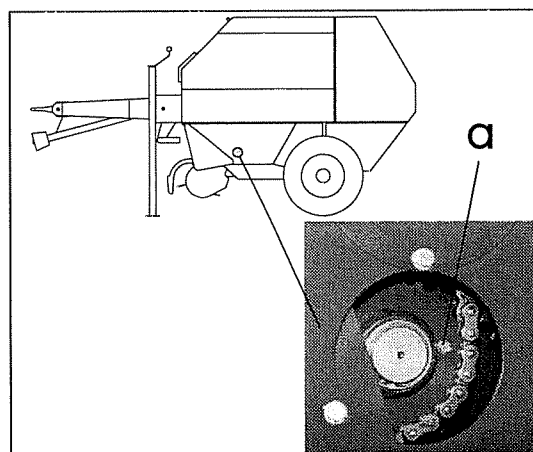

4.7 Setting scrapers

To prevent twine from emerging between the ridged rollers in the area extending from the twine feed into the chamber to the material feed opening, plastic scrapers are mounted on the machine. They are set in such a way that the revolving rollers lightly touch the entire width or project a maximum of 1 mm into the roller orbit. Adjustment is possible by loosening the bolt connections on the side walls and re-positioning the scraper edges. Finally, all bolt connections must be re-tightened.

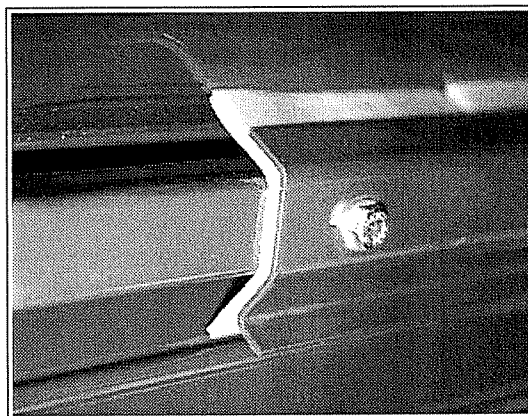

4.8 Shearing screws roller drive

In order to avoid damage to the rollers, two shearing screws M8 x 45 DIN 931 10.9 act as main safeguard (one each in the front and rear half of the baling chamber) in the roller drive. Both shearing screws are located in the double chain drive on the left-hand side of the machine at the front. Should the shearing screws brake, the corresponding hole position can be found using the reverse lever (set to hexagon).

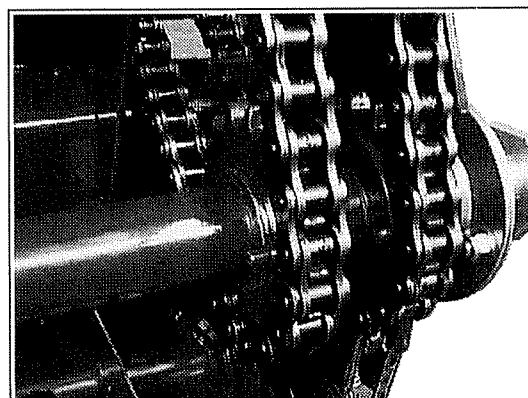

5 Operation

5.1 "Autoform" operation and control unit



Attention!

Always protect the control box from moisture and mechanical damage. Supply voltage required is 12V.

Description of push buttons:

- (1) Preselection cutter in/out; after preselection, the upper LED lights up; the lower LED lights up when the blades are swivelled in
- (2) Selects „switching the cutting mechanism on and off“; LED lights up when function is selected (Position 1 and 2 cannot be activated together)
- (3) Adjusting twine clearance to edge of bale
- (4) Selects „net wrapping“; LED lights up when function is selected
- (5) Selects „twine wrapping“; LED lights up when function is selected
- (6) Switches from automatic to manual wrapping initiation; LED lights up when manual mode is selected
- (7) Clear button; clears the day counter, clears error indications if problem has been eliminated
- (8) Activates the day counter for 3 seconds; pressing this button again will activate the total counter for 3 seconds
- (9) Program button for the number of net or twine wraps and for the automatic cutting knife engagement; Twine edge clearance; volume control for peep signal
- (10) „Autoform“ switch, 0= off, I= on, II= emergency mode, see below
- (11) Toggle switch - emergency control of net or twine wrapping system; overrides the electronic control
- (12) Cable with screw connection
- (13) LED - lights up when the blades are swivelled in

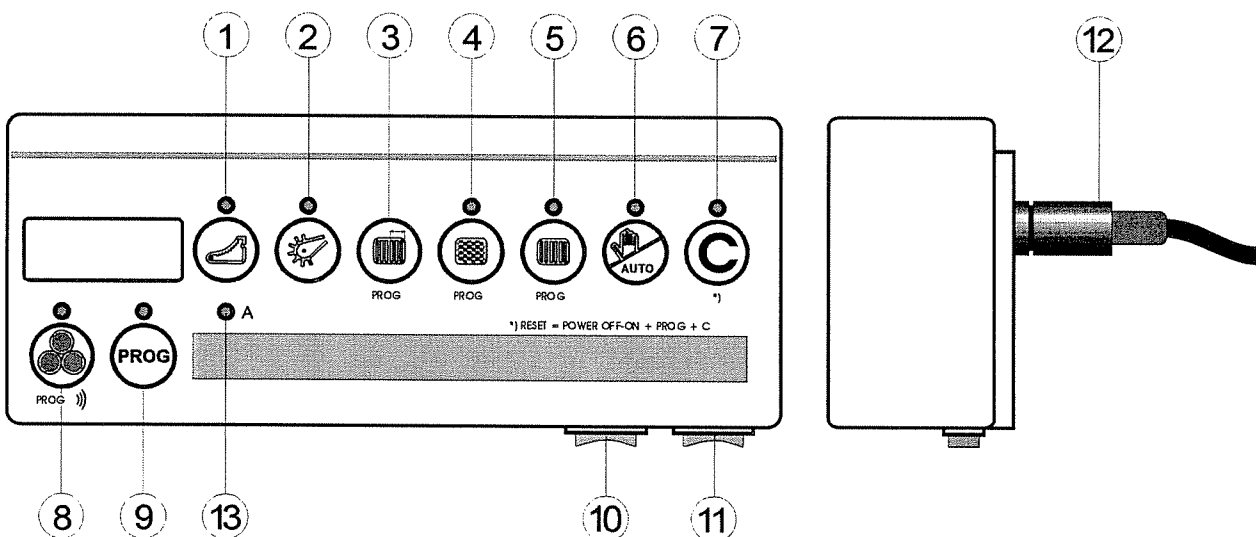

Attach the control box inside the tractor cab as described in section 4.2. The hydraulic functions of pick-up and cutting mechanism are activated using the single acting control unit. One function only can be preselected. Only one function can be preselected on the „Autoform“. The LED above the activated function lights up. The tailgate is not controlled by the control box, but directly by the double acting control unit. When the control box is switched on, a self test takes place. If the self test is successfully completed, the screen displays one of the following messages:

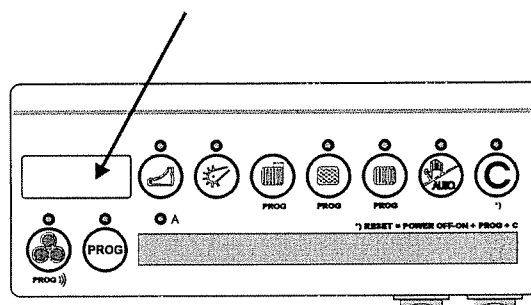

- „ - - „ Pto switched off
- „RUN“ Pto switched on
- „E #“ Error / malfunction with code number

Messages displayed during operation:

- „RUN“ Machine to be started, machine in operation, tailgate closed
- „90%“ Alerts the driver when 90% of the preselected bale density has been reached (to swing cutting knives clear see information below)
- „STOP“ Alerts the driver when the preselected bale density is reached. When in the automatic mode the selected wrapping program starts automatically. In the manual mode the tying cycle has to be started by pressing button (4) = net or (5) = twine.
- „BIND“ Shows that twine or net wrapping is running.
- „OPEN“ Alerts the driver when the wrapping process is completed and the bale has to be ejected.

Other display messages:

- „0-99999“ Day / total bale counter
- „1,5...8,0“ Programming the number of net wraps
- „14...28“ Programming the number of twine wraps
- „120-210“ Twine edge adjustment
- „CUT 0/1“ Automatic blade swivel device
- „E ##“ Error indication with code number; see below

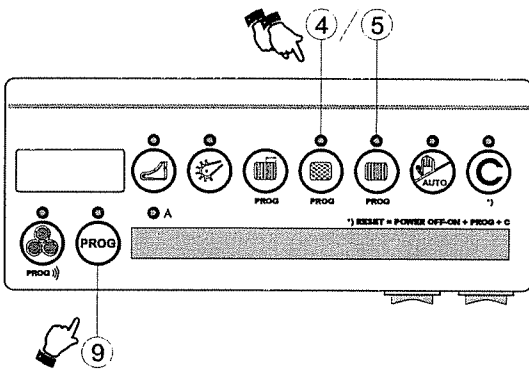

*Programming the number of net or twine wraps:
(recommendation: switch off PTO shaft!)*

- Press program button (9)
- Net:
Pressing several times net wrapping button (4) will cause the screen to display the number of net wraps by figures:
1,5 / 1,75 / 2,0 / 2,5 / 3,0 / 4,0 / 6,0 / 8,0
- Twine:
Pressing several times twine wrapping button (5) will cause the screen to display the number of twine wraps by figures from 14...28. Setting is possible in the following steps: 14, 16, 20, 24, 28.
- Use program button (9) to save the setting.

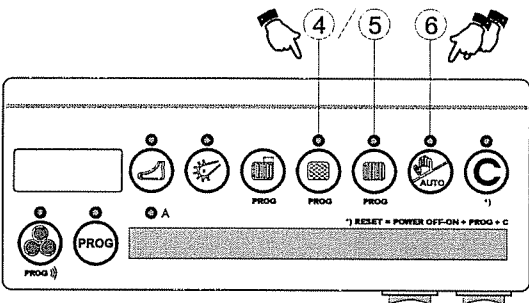

Adjustment of wrapping options:

Use button (6) to select „manual or automatic wrapping initiation“. Press this button to switch the system to the desired mode. The LED is on if „manual wrapping initiation“ is selected. Then press button 4 for net or 5 for twine to start.

Automatic binding start

After preselection of the binding option “automatic binding start”, the preset binding is automatically started after the display message “stop”.

Stop the tractor immediately!

Programming the automatic cutting knife engagement:

When 90% of the preselected bale density has been reached the buzzer creates an intermittent audible warning. That means that the cutting knives are engaged for three seconds (the buzzer sounds throughout the duration of the cutting action). Using the single acting control unit it is possible to disengage the knives during the three seconds (actuate the control unit until the audible warning stops!). To program the automatic knife engagement before the next baling cycle, follow the procedure below:

- Press program button (9)
- Press button (1) until the screen displays the desired indication „CUT 1“ = active or „CUT 0“ = inactive

„1“ If the knives are manually disengaged as described above, knives are automatically re-engaged after the bale is completed and the tailgate closed.

„0“ If the knives are manually disengaged as described above, knives are NOT automatically re-engaged. To re-engage the knives it is necessary to select the function „switching the cutting mechanism on and off“ (button 1) and to actuate the control unit.

- Use program button (9) to save the adjusted mode.

While the blades are being swivelled out, the float position for the pick up is blocked. Bring the control lever back into the float position after the swivelling stage!

Adjusting the yarn edge clearance

- Press programme button (9)
- Press edge clearance button (3). Press several times to select the edge clearance in the following graduations: 120, 150, 180, 210 (the adjustment is made automatically for both sides)
- For the minimum clearance (120), the number of hoops on the outside is approx. 1.5, or approx. 2.5 for maximum clearance (210)
- Then press programme button (9)

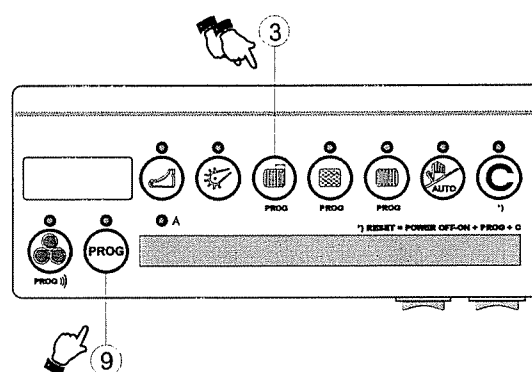
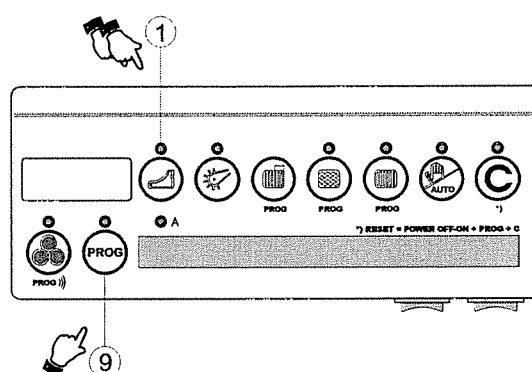

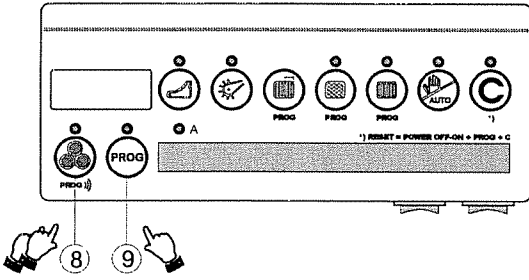

Adjusting the signal volume

- Press programme button (9)
- Press the bale counter button (8) several times to adjust the volume
- Press the programme button (9) to save the setting.

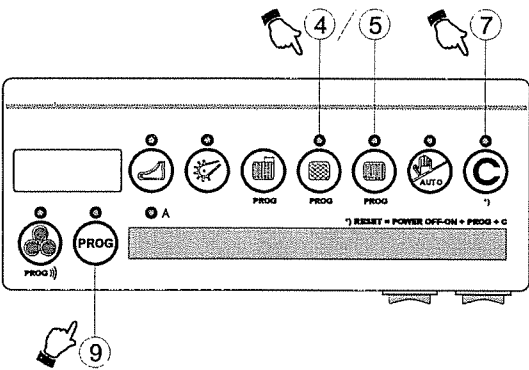

Reset: binding twineand net.

There is a reset function in the case of defects in the binding procedure for checking the zero setting or recalibration:

- Select the net binding button (4) or twine binding button (5)
- Press the programme button (9) together with the delete button C (7) (confirmation given by 2 x peep signal)
- The selected binding system is then checked

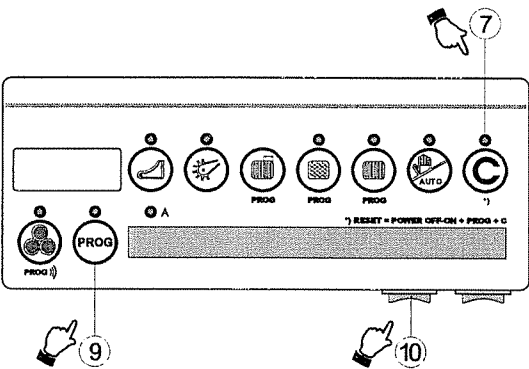

Reset: complete electronic system

Checking the complete electronic system









- Switch the control unit "Autoform" off and on again (switch 10)
- Press the programme button (9) together with the delete button C (7) (confirmation given by 2 x peep signal)
- Calibration of the extension length of the mains motor; where applicable, the zero setting of the yarn slide is re-adjusted; the internal electronic components are checked (individual settings are retained!)

Indication of errors / malfunctions:

All important functions are continually surveyed during operation and if a problem occurs the screen will display an E # message and the buzzer will create an intermittent audible warning.

The error symbol appears periodically on the screen until the problem has been overcome.

- E-01 net not running
- E-02 net runs on unless cut off, or starts up automatically
- E-03 tailgate open
- E-04 cutting bar of net wrap system not under tension
- E-05 linear motor of net wrapping system not operative
- E-06 insufficient smoothness in operation of the twine wrapping motor
- E-07 -
- E-08 -
- E-09 power supply insufficient - possibly check cable
- E-99 electronic defect, system fault

E-01	E-02	E-03	E-04	E-05	E-06	E-07	E-08	E-09	E-99
									

Emergency control of the wrapping system:

If problems occur during the wrapping cycle the electronic control system can be overridden and the net or twine wrapping system can be controlled manually.



Caution!
Even when in emergency mode, all protective coverings must be kept closed.
Risk of injury!

The wrapping cycle is running as long as you keep pressed toggle switch (11) of the control box. This function is not provided for continuous operation but should only be used to wrap just the bale which is in the bale chamber when the problem occurs. The malfunction should then immediately be repaired.

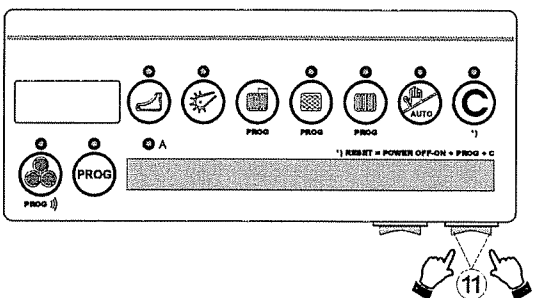
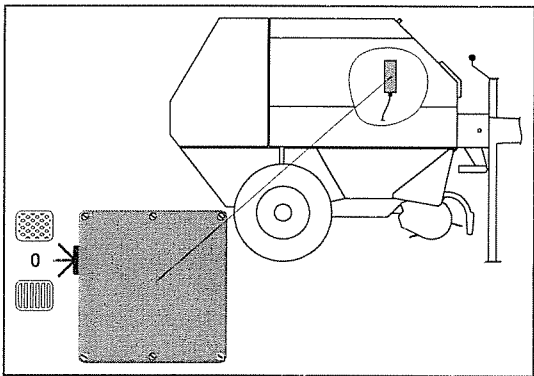

Binding with the net:

- Move the switch on the machine box (right hand side of the machine) from zero setting to the net setting (at the top).
- Move the rocker switch (11) to the left to activate net intake.
- After the net has started, release the rocker switch (check through the slots).
- After approx. 4 seconds, move the rocker switch to the right until the net is cut off (net roller at a standstill!)
- Then move the rocker switch to the left for approx. 1 second (zero setting).
- After the binding procedure is finished, move the switch on the machine box back to its zero setting.

Binding with twine:

- Move the switch on the machine box (right hand side of the machine) from zero setting to the yarn setting (at the bottom).
- Move the rocker switch (11) to the right for approx. 15 s to activate the yarn slide.
- Move the rocker switch to the left to cut off the twine + further 3 s; check through the yarn disk on the top of the machine.
- After the binding procedure is finished, move the switch on the machine box back to its zero setting.

5.2 Pick-up

The pick-up is set as described in Section 4.6. During use, the pick-up is to be positioned at the preset height above the feeler wheels on the ground, and the control unit set to floating position. Optimal and careful crop pick-up is ensured by following the lie of the ground.

When turning and when picking up extremely large volumes of crop the travelling speed is to be adjusted according.

Warning:



Only change the shear bolts on the pick-up when the engine is switched off and the machine is at a standstill. Remove the ignition key.

5.3 'Opticut' cutting system

5.3.1 General

The conveying drum (1) with its double conveying tines configured in a spiral (2) ensure that the cutting blades (3) cut in an even and drawn manner.

With the Opticut cutting system, you have the option to cut the crop at a theoretical cutting length of 70 mm at a maximum of 14 cutting points. The blades can be moved out of the conveying channel by the hydraulics alone. The number of blades can be selected freely so that the cutting lengths can be altered accordingly. The complete swivel function is therefore always retained.

Each blade has foreign body protection and is spring-loaded. When a foreign body passes over, the blade recedes into the floor of the cutting unit and then returns to the cutting position automatically.

The blades can be fixed in two different positions, giving cutting system operation in 'normal cutting' and 'precision cutting' modes.

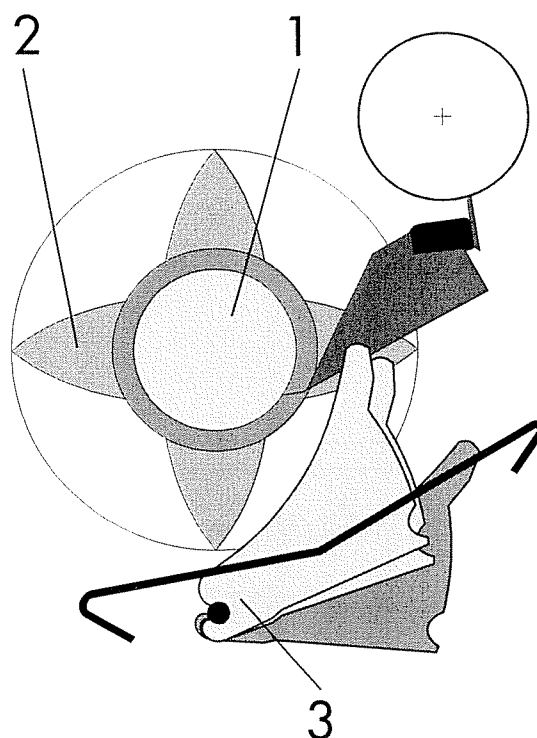

Note:

When there is a danger of blockages due to large quantities of crop, it is advisable to move out the cutting system out hydraulically for a short time to allow the crop to pass through more easily.

When moving out the cutting system at the end of the baling process, a final layer of uncut crop is laid around the bales which can minimise losses of broken crop and increase bale stability. For the operator's information, the interval audible signal in the "Autoform" indicates when 90% of the preset bale density is reached. The hydraulic shut-off tap on the left-hand side of the machine is to be closed when the cutting system is used for an extended period in the moved-out position.

5.3.2 Changing the blades

Warning:



During all work on the cutting system, switch off the engine and wait for the machine to come to a complete standstill. Close the cutting system hydraulics with the shut-off tap. Always wear protective gloves when working with the blades and never touch the blades on the cutting edge.

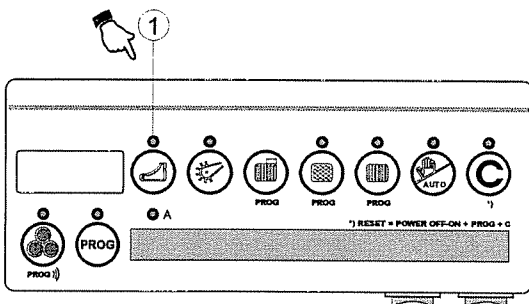

- Move out the cutting system hydraulically (1),

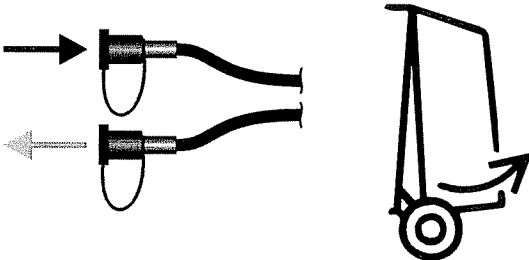

- Open the tailgate hydraulically,
- Secure the tailgate - close the hydraulic tap (see Section 1.6, Point 10),

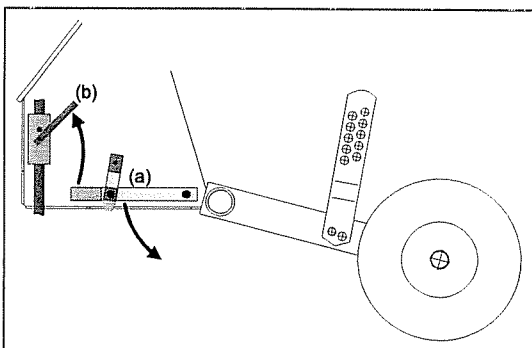

- Close the hydraulic tap (b) for the cutting system located on the right-hand side of the machine,
- Switch off the tractor engine,
- Turn the blade shaft, lower the lever (a),
- Grip the blade at the end and pull out upwards, alter the position of the conveying fines by turning the conveying drum, if necessary,
- Sharpen the blades (only when disassembled),
- Mount the blades in the reverse order.

Note:



Always keep the blades sharp. The power consumption can be reduced considerably by doing this.

5.3.3 Adjusting the cutting angle

Blade shaft, pos. 1

- steep cutting angle for 'precision cutting'

Blade shaft, pos. 2

- obtuse cutting angle for 'normal cutting'
(approx. 20% lower power consumption)

Adjusting the cutting angle from 'normal cutting' to 'precision cutting':

- Move out the cutting system hydraulically, switch off the tractor engine
- Unscrew fixing bolt M10 (a) on the left and right-hand sides,
- Undo the hinge screw M10 (b) on the left and right-hand sides,
- Move in the cutting system hydraulically, switch off the tractor engine,
- Assemble fixing screws (a) in the upper position,
- Tighten the fixing and hinge screws (a, b) at the left and right.

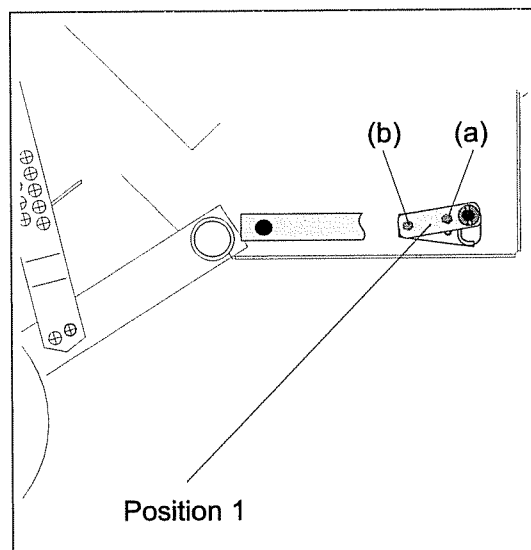

Adjusting the cutting angle from 'precision cutting' to 'normal cutting':

- Move in the cutting system hydraulically, switch off the tractor engine,
- Unscrew fixing bolt M10 (a) on the left and right-hand sides,
- Undo the hinge screw M10 (b) on the left and right-hand sides,
- Move out the cutting system hydraulically, switch off the tractor engine,
- Assemble fixing screws (a) in the lower position,
- Tighten the fixing and hinge screws (a, b) on the left and right-hand sides.

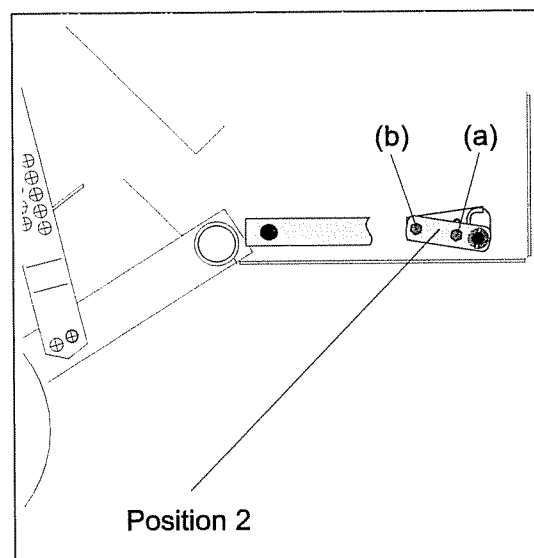

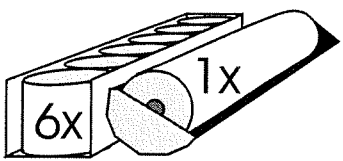
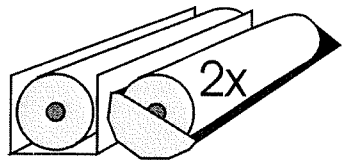
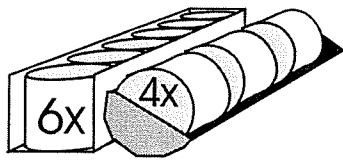
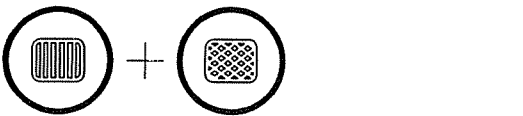
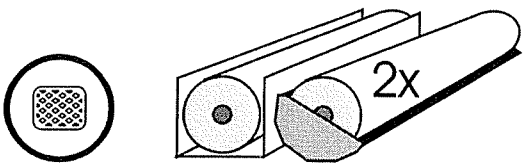
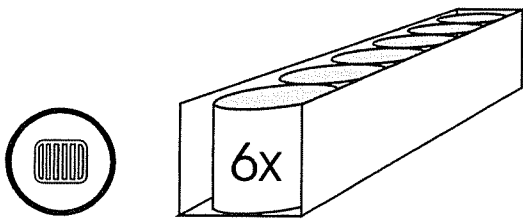

5.4 Binding

5.4.1 General

Both a net wrapping and twine binding system are available for the round baler. The baler can be fitted with either one or both binding processes. If necessary, the crop can be wrapped using both binding processes one after the other. It is also possible to retrofit either system.

To achieve the best possible standard of wrapping, quality netting with a maximum exterior roll diameter of 320 mm and a minimum width of 1230 mm is to be used. The core diameter is 76 mm, core length 1255 mm.

The following options are available for the net and twine roll assembly, see picture.

Recommended net roll manufacturers:

- BP Chemicals PlasTec GmbH
 Rosbacher Weg 5
 64720 Michelstadt
 Germany
 Postfach 3209 Postfach 7309
 64713 Michelstadt 72786 Pfullingen
 Germany Germany
- Novatex Italia S.P.A.
 Via del Peschierone N12
 Italy

Twine quality:

- Plastic twine with a running length of 400 to 700 m/kg
- Sisal twine with a running length of 200 to 330 m/kg

5.4.2 Twine binding

If the round baler is fitted with a twin-threaded twine binding mechanism, the crop can be bound into bales which are stable in shape with a preselected number of crosswise twine bindings.

The twine binding process is activated, the number of twine wraps (14 - 28) and the option for automatic or manual binding start-up are carried out using the "Autoform", see Section 5.1.

The twine container is located in front of the binding mechanism and holds 6 rolls of twine. An additional twine box is available for holding 6 extra rolls of twine (right-hand side of the machine). When equipped for net wrapping, the net roll container can also be used to hold 4 twine rolls.



Warning:

When inserting new twine rolls and when threading the twine, switch off the tractor engine and wait for the machine to come to a standstill. Remove the ignition key.

Threading twine:

- Guide the ends of the threads from the yarn rolls out of the yarn container(s) through the breakthroughs shown in the illustration
- Guide the ends of the threads through the yarn brakes (caution: different spring tension for one or two threads)
- Guide each thread through a thread tightener and porcelain eyelet
- Place each thread with a loop of approx. 360° anti-clockwise over one plastic guide roller
- Guide through the porcelain eyelet on the frame (front or back)
- Guide the thread through the upper bundle eyelets, between the rollers, guide springs and then through the lower bundle eyelets (slightly turning the rollers for thread feed)
- Thread length at the exit point: 50 mm



Caution!

Never reach into the zone of the yarn knife! Risk of injury!

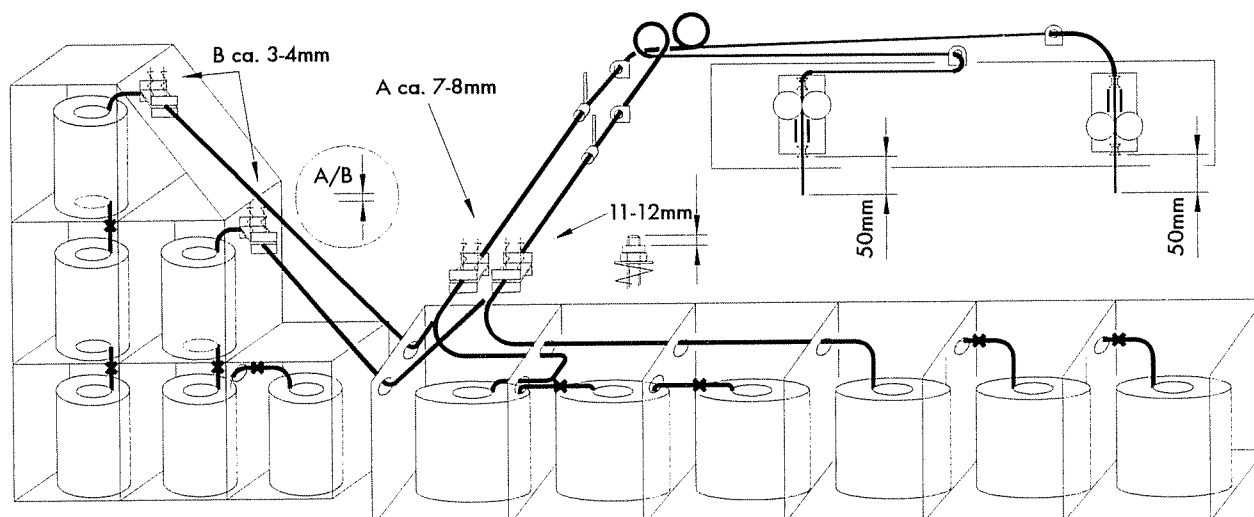

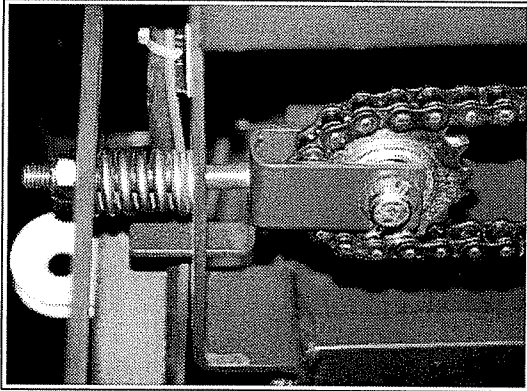

Correct length of the twine carriage tensioning chain: 44 mm. Chain has to be tensioned if lengthening occurs. The clearance of the yarn to the outer edge of the bale is adjusted by the „Autoform“ device, see section 5.1.

5.4.3 Net wrapping

When the round baler is equipped with a net wrapping system, the crop can be bound into bales with a stable shape with a preselected number of net wraps. The twine binding process is activated, the number of net wraps of (1.5 - 8) and the option for automatic or manual binding start-up are carried out using the "Autoform", see Section 5.1.

A container for a second net roll (or optionally for 6 twine rolls) is located behind the net roll being used.



Warning:

When inserting new rolls of net and when threading the net, switch off the tractor engine and wait for the machine to come to a standstill. Remove the ignition key. Do not reach into the anvil and blade area - the blade is under tension each time the tailgate is activated. There is a risk of injury.

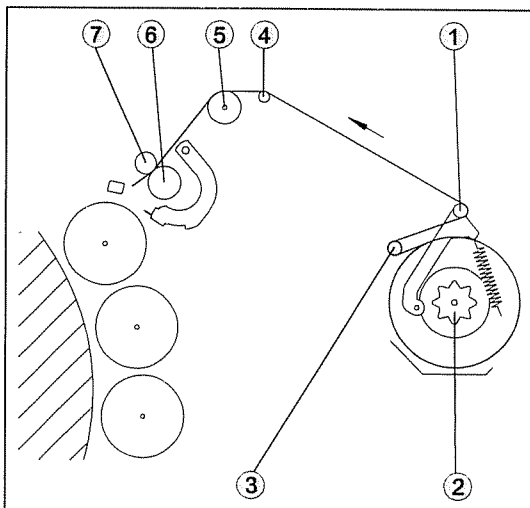

Installing the net roll, inserting the net:

- After removing the spring plug, pull out the net roller holder (right-hand side), unlock by turning the handle briefly to the right,
- Insert the roll of net, pushing the cardboard tube onto the rubber section on the left-hand roll holder,
- Slide the right-hand net roller holder into the cardboard tube, lock and secure with spring plug,
- Align the net roll to the middle of the bale chamber,

- Turn the hand wheel (2) sharply - the roll of net is fixed axially by spreading the rubber section,
- Unroll the netting from the roll, place over the guide tube and then around the netting tensioning clip(1),
- Place the net over the guide tube (4) and the plastic net spreader (5),
- Spread the start of the net folded in half and insert between the rubber roller (6) and the aluminium roller (7), turn the rubber roller (6) with an Allen key on the mount (left- hand side) until the net is securely gripped,

Checking the disk brake:

- Press lever (1) with net tensioning bar approx. 10° against spring tension
- In this position, the net roller must be just free (turns sluggishly); the default basic position depends on the diameter of the net roller!

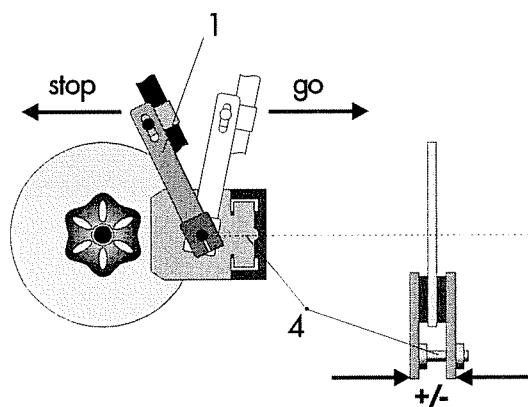

Re-adjustment:

- Fine adjustment using screw/locknut M8 (4)
- Then tighten screw/locknut (4) again
- When the net tensioning bar vibrates too much, adjust the sliding ledges (5) closer for optimum attenuation when the net is running.

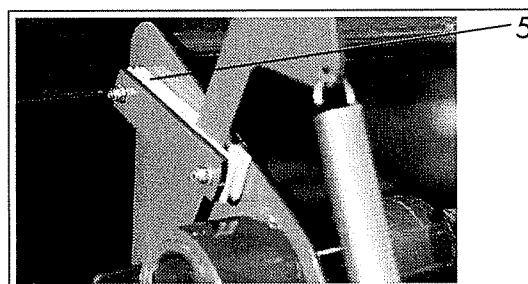

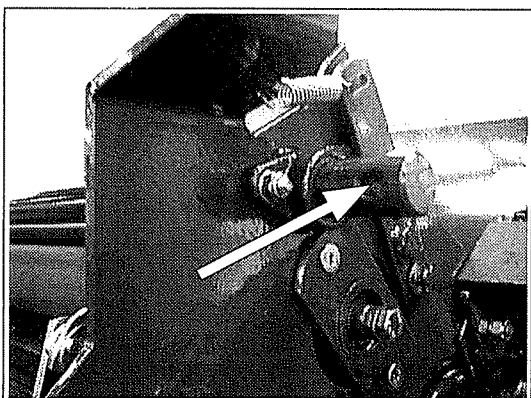
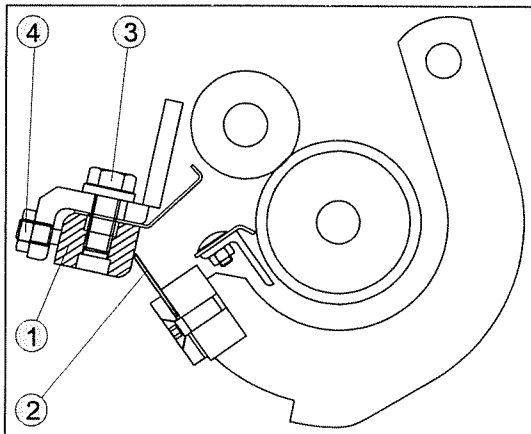

The net wrapping system does not require any maintenance.

Check the parallelism of anvil (1) and cutting bar (2) to ensure that the net is cut correctly. To adjust proceed as follows:

- Cutting bar must be released (in contact with the anvil)
- Undo the securing bolts (3) of the anvil;
- Release the lock nuts and use setting screws (4) until the anvil is parallel to the cutting bar.
- Be sure there is no gap between anvil and cutting bar and tighten the lock nuts and the securing bolts (3).

The cutting bar can be reversed three times. The hoop with the beating arm can be tensioned manually (see illustration). To do so, place suitable round material in the bore of the bearing shaft and turn until it engages firmly.

5.5 Tailgate



Warning:

Take care when opening and closing the tailgate. Shut the hydraulic shut-off tap before entering the bale chamber. No persons may remain in the swinging range of the gate.

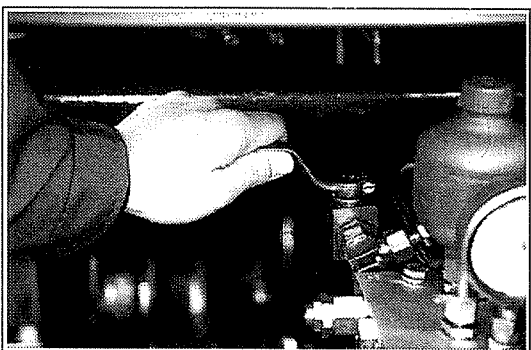

The tailgate is activated directly from the double-acting control unit. The tailgate is opened fully using the 'Raise' function on the control unit. The tailgate is closed with 'Lower' on the control unit. If the tailgate is open the control box screen displays „OPEN“.

If the tailgate is completely closed the control box screen displays „RUN“ (The P.T.O. shaft must be switched on).

5.6 Reversing mechanism



Note:

Experience shows that when the bales are nearly finished, the system can become obstructed or the cam coupling can be triggered.

It is possible to bind these bales without having to eliminate the obstruction in the vicinity of the cutting rotor. To do so, disengage the cutting rotor by reverse coupling, engage the propeller shaft at low speed, bind the bale and eject. Then stop the propeller shaft, engage the rotor again and eliminate the obstruction at a low PTO shaft speed.

When the conveying roller / cutting system is blocked, the wedge clutch switches the torque to 'zero'. If the blockage can not be cleared by restarting the PTO shaft at a speed less than 200 rpm, the conveying channel is to be freed of blocked crop by reversing the conveying roller.

Proceed as follows to reverse:

- Move the blades out of the conveying channel hydraulically,
- Switch off the PTO shaft, switch off the tractor engine, remove the ignition key,
- Disconnect the coupling claw via the lever,
- Remove the reverse lever from the drawbar spar and place on the hexagon,
- To reverse, turn anti-clockwise and convey the crop out of the conveying channel by turning the conveying roller back,
- After dealing with the congestion, turn the reverse lever briefly in the other direction so that the drive chain can be tightened in the direction of travel,
- Fit lever to its support on the drawbar and re-engage the claw clutch.

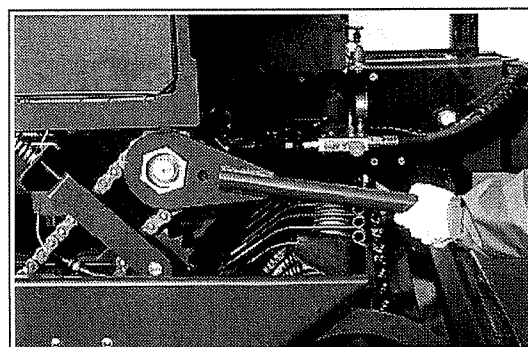
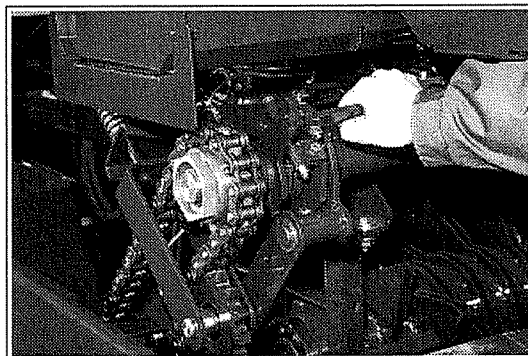

5.7 Hitching to the tractor and road travel

- Hitch the round baler to the tractor, see Section 4.3 for drawbar adjustment,
- Mount the universal drive shaft, see Section 4.4, prevent from turning incorrectly by using the retaining chain,
- Connect up all hydraulic hoses and power supply cables,
- Turn prop stand up to the limit stop, remove safety pin, fold up prop stand, fit safety pin at the bottom and secure by R-clip.
- Before driving off, raise the pick-up hydraulically as far as it will go.
- When driving around tight corners, make sure that deviation is no greater than 80° on the wide-angle of the universal drive shaft (on the tractor). Otherwise there is a danger of breakage during operation or when at a standstill.
- It is not allowed to transport a bale inside the chamber! When leaving the field the last bale has to be kicked out.

5.8 Operation in the field

Extensive protection against possible accidents is provided by the round baler. However, sufficient care and caution should be taken when working with the machine. Checks should be made each time the machine is used to see that all protective devices are mounted and intact.



Warning:

Never repair functional errors during operation. Particular care should be taken when opening and closing the tailgate. No persons may remain in the tailgate swinging range. Shut the hydraulic shut-off tap before entering the bale chamber.

Before starting work:

- Insert twine, net, and thread
- Adjust the height of pick-up feeler wheels
- Adjust the pick-up spring suspension
- Pre-select the bale density
- Reset the daily bale counter to zero
- Select the binding option
- Cutting system on/off
- PTO shaft speed 540 rpm

Driving:

Make sure that the bale chamber is filled with crop optimally to make the most of the round baler's capabilities. The chamber is filled evenly by driving in a suitable way, i.e. driving alternately on the left and right-hand sides of the swath when the swaths are middle-sized or small.

When hitching using a pending attachment, be aware of the tendency for heaps to form due to crop becoming caught up.

When turning sharp corners, e.g. when turning round, make sure that no deviation is greater than 80° on the wide-angle of the universal drive shaft (on the tractor). Otherwise there is a danger of breakage during operation or when at a standstill.

To obtain the best possible ground contour following, select the „pick-up“ function (button 1 of control box) and set the hydraulic system to floating position before starting work. After any activation of the knife function during the baling cycle, the system should be switched to „pick-up“ again.

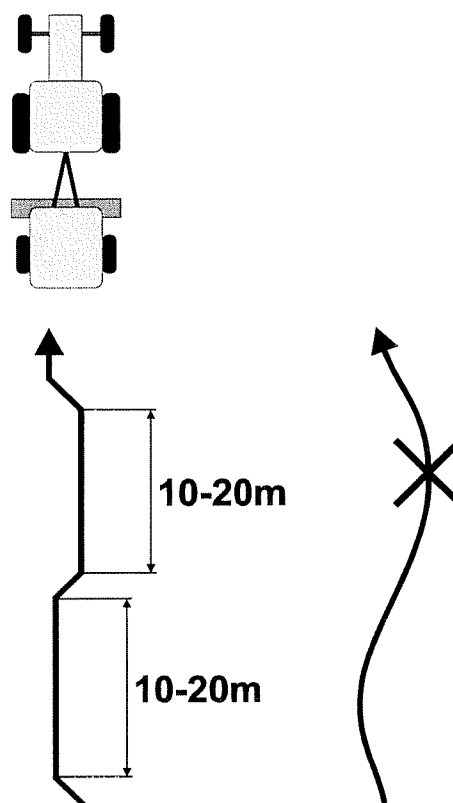
**Note:**

Material density and bale shape are improved if you reduce the driving speed from the time the "Autoform" signal '90% bale density reached' is given.

Tips for practical use:

- Twine edge clearance:
in the case of green products, it is advisable to wind the yarn at the outer edge for good bale stability, and nearer to the inside for straw.
- Number of hoops:
for optimum bale consistency, it is advisable to have more hoops for straw than for green products.
- Pressing density:
as a general rule, more pressing pressure for moist/wet products, less for dryer products.
- Pressing pressure:
for very dry, brittle straw, reduce the pressing density or swivel out the blades to prevent a standstill of the bales.

5.9 Storing the Round Baler

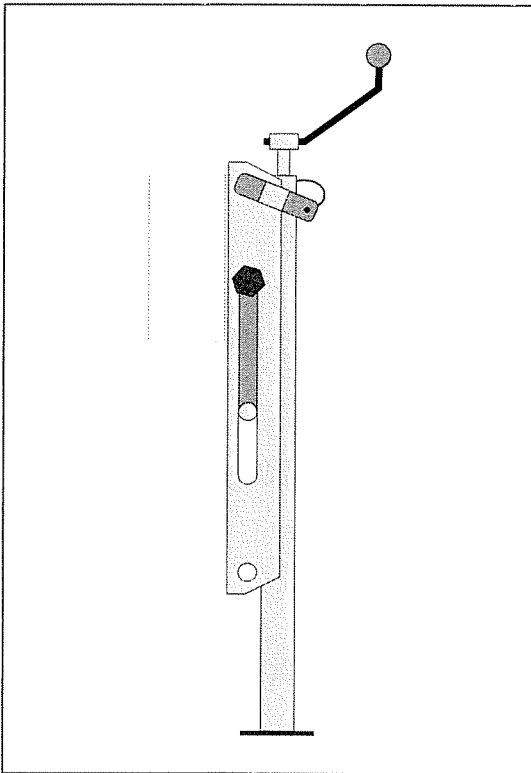

Before unhitching the Round Baler, remove the pto drive shaft, disconnect the electric cable and the hydraulic couplers from the tractor (Release pressure in the system first - briefly open the tailgate, then return to zero setting) and lower the prop stand as follows:

- Remove the safety pin and fold down the prop stand;
- Fit safety pin at the top and secure by R-clip.
- Turn prop stand down until drawbar is fully relieved of load.
- Place chock blocks under the wheels before unhitching the Round Baler.



Attention!

Store machine on a level area only and place chock blocks under the wheels to ensure the machine will not move away.

5.10 Winter storage

- Clean the baler of crop remains and dirt,
- Check the round baler for wear and damage and have it repaired,
- Release the cutting bar of the net wrapping system (bar must be in contact with the anvil);
- Attention! Keep hands clear of the working area of cutting bar and anvil. Danger of injury!
- Clean all roll chains thoroughly and re-oil,
- Lubricate all bearings on the ridged rollers,
- Lightly oil the Opticut cutting blades,
- Lubricate machine according to lubrication schedule,
- Change the gear oil,
- Position the baler so that it is stable and prevent from rolling away using wheel chocks,
- Never allow children to play on or near the machine.

6 Service and maintenance



Warning:

Never carry out adjustment or repair work, or service and maintenance work, on the machine when in operation. Switch off the tractor engine, remove the ignition key and wait for the machine to come to a standstill before working on moving machine parts. Shut the hydraulic shut-off tap before entering the bale chamber. Take care when opening and closing the tailgate. No persons may remain in the swinging range.

To ensure the efficient running of the round baler and to avoid premature repairs, make sure that the machine is well looked-after and that repairs are carried out in time.

6.1 Re-tightening screws

All screws and nuts should be re-tightened after 20 operating hours according to the given torques, see Section A.1.

Retaining screws and locking nuts should be tightened by an additional 10%.

6.2 Checking wheels

Check that the wheel nuts and wheel caps are secure. The air pressure in the tyres should be 1.5 bar. Re-tighten the wheel nuts after the first few operating hours. The torque moment for wheel nuts M18 x 1.5 is 325 Nm.

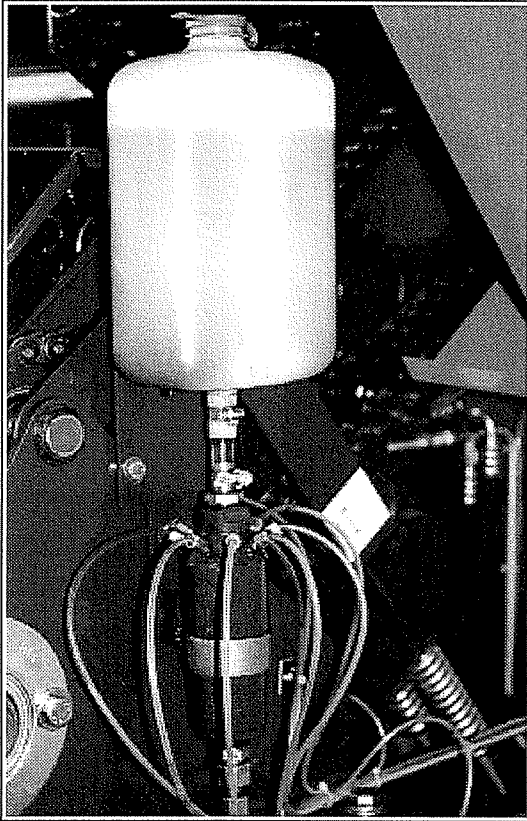

6.3 Central chain lubrication device

To reduce the amount of maintenance needed for the drive chains, an automatic chain central lubrication device is provided as standard equipment. The oil level in the lubricant container is to be checked daily. If necessary, the adhesive oil for the chain (biological chain oil) should be topped up.

The distribution pump is connected to the tailgate hydraulic system and is activated by the pressure pulse when opening the tailgate. A given amount of lubricant is pumped from the oil container into the supply pipes and applied to the chains using brushes. The brushes should be adjusted so that they are just touching the chains.

6.4 Chain tightener

All drive chains are tightened elastically by spring-loaded chain tighteners. The chain tighteners are to be assembled in the chain row so that they can move freely with no torsion and that the wear on chains and chain wheels is reduced to a minimum.

The given spring lengths of the chain tightener are to be checked regularly and re-adjusted if necessary.

Chain tightener spring lengths:

- Cutting system drive, right
- 140 mm
- Double chain tensioner for roller drive Machine front part / tailgate
- 2 x 140 mm
- Roller drive on front left of machine
- 125 mm
- Roller drive on tailgate, left
- 125 mm
- Yarn binding drive / to the right
- 44 mm

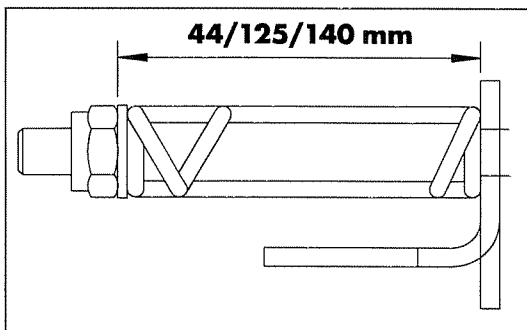

6.5 Lubrication

- | | | |
|---|----------------------|--------------------------------------------------------------------------------------------------|
| 1 | PTO shaft | - daily, all bearings, grease nippels and friction faces |
| 2 | gear box | - 1.3 litres gear oil SAE 90, only in case of repair |
| 3 | chains | - central lubrication system, keep the plastic tank fullfilled - check daily |
| 4 | roller bearings | - 2 x 18 bearings after cleaning the baler by high pressure cleaning equipment and before winter |
| 5 | opticut rotor | - 3 x bearings after cleaning the baler by high pressure cleaning equipment and before winter |
| 6 | Hydraulic oil filter | - replace filter cartridge every year before the start of the season. |



Caution!

Release pressure in the system before opening the filter housing. Close the lever to lock the tailgate!

Venting the system:

- Connect the hydraulic lines to the tractor
- Unscrew the line between the filter housing and hydraulic block to let air escape
- Press the control lever in the direction "close tailgate" until oil comes out of the union
- Tighten the union

7. Yarn binding drive - the drive chain of the yarn binding device should be well oiled every twelve months.

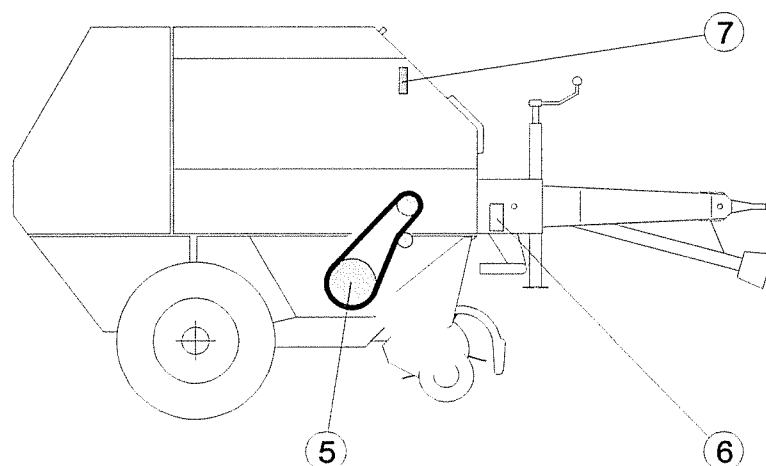
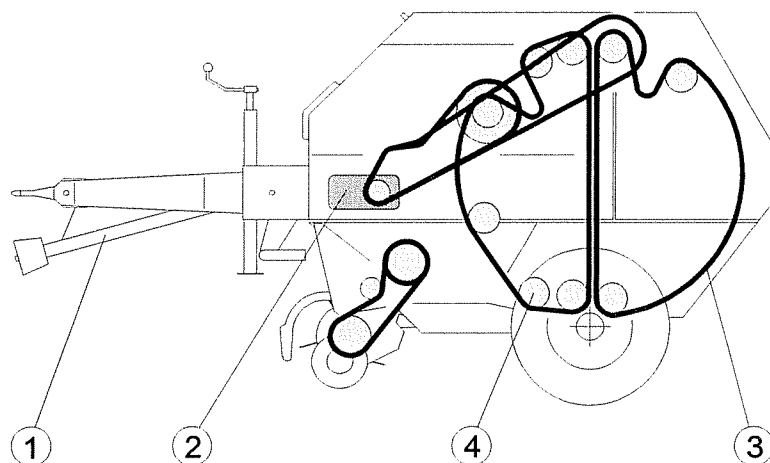

7 Accessories

7.1 Cutting system

The round baler is prepared for fitting the 'Opticut' cutting system as standard. When delivered without cutting system, components such as the conveying drum and cutting-unit floor are included in the basic machine supply schedule.

The assembly component 'Opticut cutting system' for retrofitting includes a blade unit with mechanical components and hydraulic and electrical controls.

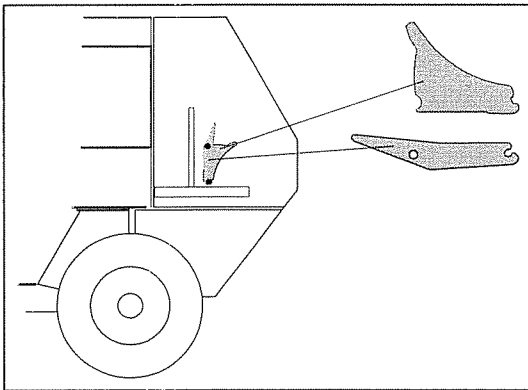

7.2 Filler plates

When the cutting device is not mounted or if the cutting system is being used with less than 14 blades, the slits in the floor of the cutting unit are to be closed using filler plates. The filler plates keep the blade slits clean and ensure that the flow of material around the floor of the cutting unit remains even. The filler plates are stored on the machine and are located on the left-hand side wall of the baler underneath the protective plates. Dismantled blades can also be placed on this mount.

7.3 Bale ramp

When using the bale ramp, the bales are deposited gently onto the ground and roll out of the tailgate area so that, under normal working conditions, it is not necessary to drive forward again to close the tailgate.



Caution!

Only open the tailgate when the machine is running to make sure that the bale is ejected.



Warning!

On sloping ground, the bales should be deposited face down on the slope. There is a risk of injury if the bales roll away.

7.3.1 Sensor for bale ejection

In combination with the bale conveyor, confirmation can be given that the bale has been ejected. A sensor is responsible for this together with an acoustic signal on the "Autoform" control unit which sounds once the bale conveyor has returned to its initial position.

7.4 Additional twine box

To increase the twine supply, it is possible to mount an additional twine box onto the right-hand side of the machine. The size of the twine compartment (height 300 mm, length/width 265 mm) means that 6 rolls of twine can be contained in the stepped box.



7.5 Extension cable for "Autoform"

When using special tractors where the distance from the tractor cab to the baler is longer than usual, it is possible to unfasten the "Autoform" cable on the rear wall of the box (screw fitting) and to use a 1.5 m extension.

7.6 Hydraulic oil filter

When the press is used on several different tractors, there is a risk of clogging as a result of frequent connecting and disconnecting. A hydraulic oil filter can be integrated in the hydraulic system in order to prevent malfunctions.

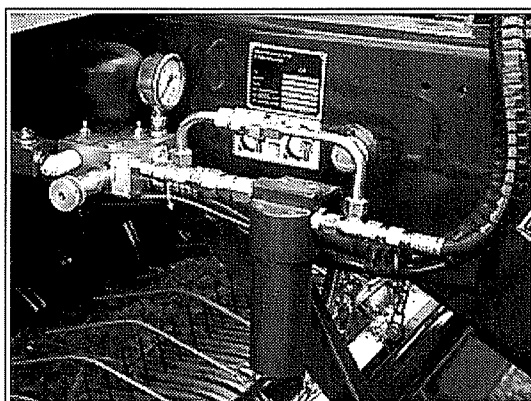

8 Fault finding

Error no.-	Fault	Possible cause	Rectification
E 01	Net does not work	Net roller empty	Insert new roller
		Net roller incorrectly fitted	Insert roller as per chap. 5.4.3
		Net brake too tight	Adjust brake to chap. 5.4.3
		Belt slides on pulley	Replace belt
		Linear motor does not leave zero position	Check spindle setting; zero setting - extended approx. 18 mm
		Dirt between rubber and aluminium roller	Remove dirt
		Net winds around rubber or aluminium roller	Check surface for damage; Adjust scraper
		Sensor defect	Check LED on sensor or in machine box
E 02	Net is not cut off and runs on	Cutting ledge not exactly parallel to anvil	Check parallel setting, adjust to chap. 5.4.3
		Linear motor does not unlock handle of cutting ledge	Check power supply to linear motor
		Cutting ledge blocked by dirt, no impulse from net sensor	Clean whole area
		Net fed before reaching pressing pressure; fringes caught up in bale	Net not cut off cleanly; check cutting ledge and anvil are parallel
		Belt not properly separated from pulley	Check zero setting of linear motor (see above); Eliminate obstruction in pulley
		Cutting edge of the bearing arm worn	turn or replace the beating arm
E 03	Tailgate not closed	Tailgate not completely closed	Close tailgate with application of pressure until pressure gauge shows preset pressure
		Pressed matter between flap and front section	remove pressed matter, clean area

Error no.-	Fault	Possible cause	Rectification
E 04	Cutting ledge of net binding device not ready	No signal at net sensor	Check LED in machine box
		Cutting ledge path too short	Check setting of draw bar
		Linear motor not in zero position, handle not locked	Reset net binding device, chap. 5.1
		Locking nose of cutting ledge worn	Replace worn part
E 05	No impulses from linear motor net binding unit	Linear motor sensor defect	Check LED in machine box
E 06	No twine impulse from gear wheel	Sensor defect	Sensor must flash when slide moves
		Wrong sensor clearance	Clearance gear wheel/ sensor approx. 1 mm
		Drive chain sluggish	Remove dirt
		Motor not working	Check contacts
		Motor without power transfer	Check connection motor/ drive pinion
E 09	Versorgungsspannung unzureichend	Voltage under 8 V	Install power supply directly from tractor battery - cable with connector included
E 99	Insufficient power supply	System fault	Do reset, chap. 5.1
		Eprom change	Ditto
---- S.A.	no connection between "Autoform" and machine box	Incorrect poles in connection lead	Change poles
		Fault in machine box	red LED in machine box must flash
		Incorrect EPROM connection	correct
		"Autoform" defect	When LEDs in machine box function and error is displayed, the "Autoform" is defect
--	no "run" message in display when machine working	Wrong sensor clearance	Sensor/magnet clearance 3 - 5 mm (behind drive disk for net binding, front right of machine)
		Sensor defect	Check LED in machine box

A Appendix

A.1 Torque values for international metric thread joints

All bolted joints must be torqued in accordance with the values given in this table unless otherwise indicated. On this machine „8.8“ is both the standard and minimum quality used.



Warning!

When lock bolts or lock nuts are used the given value must be increased by 10%.

Thread	Torque value for material quality codes in acc. with DIN ISO 898 (dry)						size of jaw		Remarks
	8.8		10.9		12.9		mm	inch	
	Nm	lbf-ft*	Nm	lbf-ft*	Nm	lbf-ft*			
M3	1,9	(11,5)	1,8	(16,0)	2,1	(18,6)	6	1/4	*value in brackets =lbf-in.
M4	2,9	(25,5)	4,1	(36,5)	4,9	(43,5)	8	5/16	
M5	5,7	(50,5)	8,1	(71,5)	9,7	(86,0)	9	23/64	
M6	9,9	7,3	14	10,3	17	12,5	10	13/32	
M8	24	17,7	34	25,0	41	30,3	14	9/16	
M10	48	35,4	68	50,2	81	59,8	17	11/16	
M12	85	62,7	120	88,6	145	107	19	3/4	
M14	135	99,6	190	140	225	166	22	7/8	
M16	210	155	290	214	350	258	24	121/128	
M18	290	214	400	295	480	354	27	1 9/128	
M20	400	295	570	421	680	502	30	1 3/16	
M22	550	406	770	568	920	679	32	1 17/64	
M24	700	517	980	723	1180	871	36	1 27/64	
M27	1040	767	1460	1077	1750	1291	41	1 79/128	
M30	1410	1041	1980	1461	2350	1734	46	1 13/16	
M33	1910	1410	2700	1996	3200	2362	50	1 31/32	
M36	2450	1808	3450	2546	4150	3063	55	2 11/64	
M39	3200	2362	4500	3321	5400	3985	60	2 3/8	
Tensile strength	8.8		10.9	12.9					
	≤ M16	≥ M16							
N/mm ²	808	830	1040	1220					
lbf/sq.in.	117,222	120,414	150,880	176,994					

A.2 Hydraulic scheme

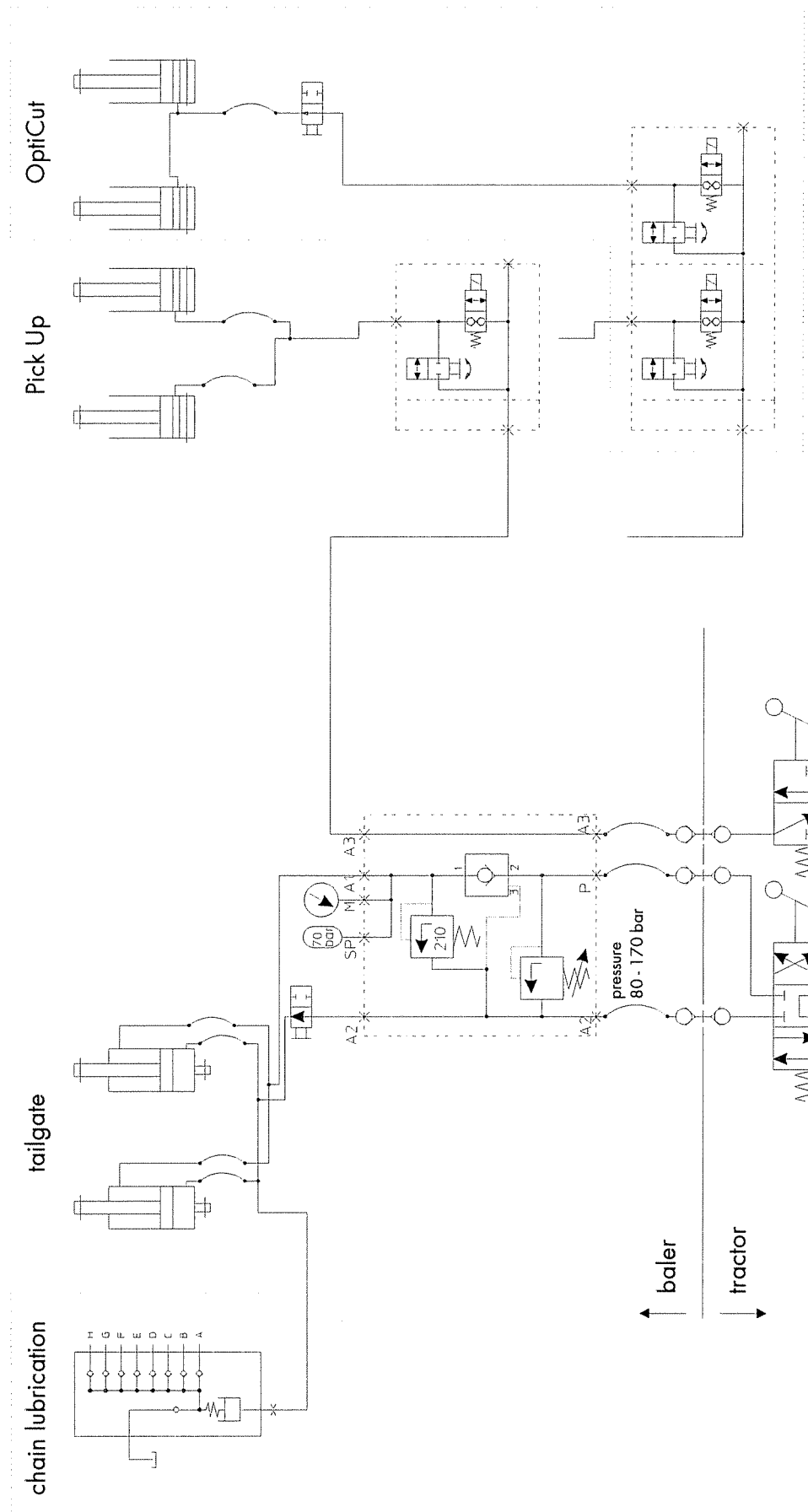



Kverneland Gottmadingen
GmbH & Co. KG
Hauptstraße 99
78244 Gottmadingen
Germany

Tel. +49 7731 788 0
Fax +49 7731 788 353

Prod. series nr. 11 -

effective from ident. nr. (PIN)

Type 0101